

APPENDICES

The Appendices are structured as follows:

- A: Applies primarily to Type A Power Generating Facilities
- B: Applies to Types B, C and D Power Generating Facilities
- C: Applies to Types C and D Power Generating Facilities
- D: Applies to all Power Generating Facilities

APPENDICES	1
Appendix A.1 Type A Power Generating Facility Forms Cover Sheet	5
Appendix A.2 Type A Power Generating Facility Connection Application Form	6
Appendix A.3 Installation Document for Type A Power Generating Facilities.....	8
Appendix A.4 Type A Compliance Verification Report.....	10
Appendix A.5 Emerging Technologies and other Exceptions.....	17
Appendix A.6 Example calculations to determine if unequal generation across different phases is acceptable or not.....	19
Appendix A.7 Non-Standard private LV networks calculation of appropriate protection settings.....	20
Appendix A.8 Requirements for Type Testing Power Generating Modules.....	21
Appendix B.1 Installation and Commissioning Confirmation Form.....	29
Appendix B.2 Power Generating Module Document for Type B and Type C.....	31
Appendix B.3 Additional Compliance and Commissioning test requirements for PGMs	34
Appendix B.4 Simulation Studies for Type B, Type C and Type D Power Generating Modules.....	38
Appendix B.5 Compliance Testing of Synchronous Power Generating Modules	44
Appendix B.6 Compliance Testing of Power Park Modules	49
Appendix C.1 Performance Requirements For Continuously Acting Automatic Excitation Control Systems For Type C and Type D Synchronous Power Generating Modules.....	54
Appendix C.2 Performance Requirements for Continuously Acting Automatic Voltage Control Systems For Power Park Modules	57
Appendix C.3 Functional Specification for Fault Recording and System Monitoring Equipment.....	Error! Bookmark not defined.
C.3.1 Purpose and Scope.....	Error! Bookmark not defined.
C.3.2 Functional Requirements	Error! Bookmark not defined.
Appendix D.1 Power Generating Module Decommissioning Confirmation	68
Appendix D.2 Additional Information Relating to System Stability Studies	69
Appendix D.3 Loss of Mains (LoM) Protection Analysis	72

Fully Type Tested and Partially Type Tested equipment

The following matrix demonstrates where **Manufacturers' Information** and compliance and installation checks on site can be combined to demonstrate compliance for each **Power Generating Module**.

	Manufacturers' Information	Site Tests
Fully Type Tested (assumed Type A only)	Registered as Fully Type Tested information on ENA website via the Compliance Verification Report (A.4)	Only installation checks required – as on the Installation Document (A.3)
Partially Type Tested (Type A)	<ul style="list-style-type: none"> (i) Registered as product or component Type Test information on ENA Website using applicable parts of Compliance Verification Report (A.4); and/or (ii) Supplied by the Generator using applicable parts of Compliance Verification Report (A.4) 	<p>Demonstration of technical requirements not covered by Manufacturers' Information. (A.4)</p> <p>Standard installation checks also required (A.3)</p>
Partially Type Tested (B, C, D)	<ul style="list-style-type: none"> (i) Registered as product or component Type Test information on ENA Website; and/or (ii) Supplied by the Generator 	<p>Demonstration of technical requirements not covered by Manufacturers' Information. (B.2)</p> <p>Standard installation checks also required (B.3)</p>
One off installation	To be provided by the Generator for those aspects that cannot be demonstrated on site (including simulations etc)	<p>Demonstration of technical requirements not covered by Manufacturers' Information. (B.2)</p> <p>Standard installation checks also required (B.3)</p>

Appendix	Application	Form Title
-----------------	--------------------	-------------------

A.1	Cover Sheet for Type A Power Generating Facility Forms	
A.2	Connection Application for Type A Fully Type Tested (<50kW) Note for all other PGMs the DNO's common application form shall be used.	Type A Power Generating Facility Connection Application Form
A.3	Installation and Commissioning a Power Generating Facility comprising one or more Type A Generating Modules	Installation Document for Type A Power Generating Facilities
A.4	Compliance report for Type A Type Tested	Type A Compliance / Type Test Verification Report
A.5	Emerging Technologies and other Exceptions	
A.6	Example calculations to determine if unequal generation across different phases is acceptable or not	
A.7	Non-Standard private LV networks calculation of appropriate protection settings	
A.8	Detailed test requirements for Type Tested PGMs	Requirements for Type Testing Power Generating Modules
B.1	Installation and Commissioning of Type B, Type C and Type D PGFs	Installation and Commissioning Confirmation Form
B.2	Compliance documentation for Type B, Type C and Type D PGFs	Power Generating Module Document for Type B, Type C and Type D

B.3	Additional compliance and commissioning tests for Type A (under some circumstances) Type B, Type C and Type D PGMs	Additional Compliance and Commissioning test requirements for PGMs
B.4	Simulation Studies for Type B, Type C and Type D Power Generating Modules	
B.5	Compliance Testing of Synchronous Power Generating Modules	
B.6	Compliance testing of Type B, Type C and Type D Power Park Modules	
C.1	Performance Requirements For Continuously Acting Automatic Excitation Control Systems For Type C and Type D Synchronous Power Generating Modules	
C.2	Performance Requirements For Continuously Acting Automatic Excitation Control Systems For Type C and Type D Power Park Modules	
C.3	Functional specification for fault recording	
D.1	Decommissioning of any Power Generating Module	Power Generating Module Decommissioning Confirmation
D.2	Additional Information Relating to System Stability Studies	
D.3	Loss of Mains Protection Analysis	
D.4	Main Statutory and other Obligations	

Appendix A.1 Type A Power Generating Facility Forms Cover Sheet

A number of forms are required to be completed and submitted to the **DNO** for the connection of **Type A PGMs** and any subsequent modifications to equipment, and/or permanent decommissioning. These are summarised in the table below. The stages in the table below are described in more detail in the Distributed Generation Connection Guides, which are available free of charge on the Energy Networks Association website¹.

Stage	Form	Notes / Description	Complete
1. Find an Installer	N/A	No form required – see ENA Distributed Generation Connection Guides for more information. Outside of the scope of this document.	
2. Discuss with the DNO	N/A	As above.	
3. Submit application	(A) Application form (< 50 kW) OR Standard application form (> 50 kW)	Submit an application, so that the DNO can assess whether there is a requirement for network studies and network reinforcement, and whether they want to witness the commissioning. PGMs < 50 kW 3-phase or 17 kW single phase, Form (A) can be used. For larger schemes, the standard application form should be used, which is generally available on DNO websites.	
4. Application acceptance	N/A	If the DNO determines that network reinforcement is required to facilitate connecting your PGMs , they will make you a Connection Offer . Once you have accepted the DNO's Connection Offer , construction can begin. See ENA Distributed Generation Connection Guides for more information.	
5. Construction and commissioning	See below.	Where the DNO does not witness commissioning, the forms (below) should be submitted within 28 days. Where the DNO does witness, the forms can be signed and submitted on the day.	
6. Inform the DNO	(B) Installation document	Submit one form per PGM , signed by the owner and Installer.	
	(C) Compliance Verification Report	To be provided, unless a Type Test Reference number is available for Fully Type Tested PGMs (see section 16.2.1). See the note below this table on the options for the Compliance Verification Report Form.	
7. Ongoing responsibilities	Modification	If a modification is made to the PGM that affects its technical capabilities and compliance with this document, the Customer should inform the DNO who may require compliance tests.	
	(D) Notification of decommissioning	Notify the DNO about the permanent decommissioning of a PGM .	

The forms have been designed with the same format of **Customer** and **Installer** information at the top of each form. If you are completing forms electronically, this will allow you to copy and paste your information from one form to another, as you move through the stages of the connection process, unless you need to update your contact details.

¹ <http://www.energynetworks.org/electricity/engineering/distributed-generation/dg-connection-guides.html>

Appendix A.2 Type A Power Generating Facility Connection Application Form

Form (A) : Application for connection of Type Tested PGM(s) with Total Aggregate Capacity <50 kW 3-phase or 17 kW single phase

For PGMs < 50kW 3-phase or 17 kW single-phase, this simplified application form can be used. For PGMs with an aggregate capacity > 50 kW 3-phase, the connection application should be made using the standard application form (generally available from the DNO website).

To ABC electricity distribution DNO
99 West St, Imaginary Town, ZZ99 9AA abced@wxyz.com

Customer Details:

Customer (name)

Address

Post Code

Contact person (if different from Customer)

Telephone number

E-mail address

MPAN(s)

Installer Details:

Installer

Accreditation / Qualification

Address

Post Code

Contact person

Telephone Number

E-mail address

Installation details:

Address

Post Code

MPAN(s)

Details of Existing PGMs – where applicable:

Manufacturer / Reference	Approximate Date of Installation	Technology Type	Type Test Ref No. if available	PGM installed capacity (kW)				
				3-phase units	Single Phase Units			Power Factor
					PH1	PH2	PH3	

Details of Proposed Additional Generating Unit(s):

Manufacturer / Reference	Approximate Date of Installation	Technology Type	Type Test Ref No. if available	PGM installed capacity (kW)				
				3-phase units	Single Phase Units			Power Factor

Balance of Multiple Single Phase Generating Units – where applicable

I confirm that design of the Customer's Installation has been carried out to limit output power imbalance to below 16A/phase, as required by EREC G99.

Signed :	Date :
<p>Use continuation sheet where required.</p> <p>Record PGM capacities, in Registered Capacity kW at 230V AC, to one decimal place, under PH1 for single phase supplies and under the relevant phase for two and three phase supplies.</p> <p>Detail on a separate sheet if there are any proposals to limit export to a lower figure than the aggregate Registered Capacity of all Generating Units in the PGM.</p>	

Appendix A.3 Installation Document for Type A Power Generating Facilities

Form (B): Installation Document for connection under G99

Please complete and provide this document for every **PGM** installed. Where multiple **PGMs** will exist within one premises, once installation is complete please provide **Installation Documents** for each **PGM**. For example, if three **PGMs** are to be installed in a single location then three **Installation Documents** need to be provided, and the "Summary details of **PGMs**" section at the end of this form needs to be completed.

To ABC electricity distribution DNO
99 West St, Imaginary Town, ZZ99 9AA abcd@wxyz.com

Customer Details:

Customer (name)	
Address	
Post Code	
Contact person (if different from Customer)	
Telephone number	
E-mail address	
MPAN(s)	
Customer signature	

Installer Details:

Installer	
Accreditation / Qualification	
Address	
Post Code	
Contact person	
Telephone Number	
E-mail address	
Installer signature	

Installation details

Address Including Post code	
Location within Customer's Installation	
Location of Lockable Isolation Switch	

Summary details of PGM - where multiple PGMs will exist within one premises.

Manufacturer / Reference	Date of Installation	Technology Type	Type Test Ref No. Or Manufacturers' Info. Ref. As applicable	PGM installed capacity in kW				Power Factor
				3-Phase Units	Single Phase Units			
					PH1	PH2	PH3	

Information to be enclosed

Description	Confirmation
Schedule of protection settings (may be included in circuit diagram)	Yes / No*

Final copy of circuit diagram	Yes / No*
Commissioning Checks	
Customer's Installation satisfies the requirements of BS7671 (IET Wiring Regulations).	Yes / No*
Suitable lockable points of isolation have been provided between the PGMs and the rest of the Customer's Installation .	Yes / No*
Labels have been installed at all points of isolation in accordance with EREC G99.	Yes / No*
Interlocking that prevents PGMs being connected in parallel with the DNO system (without synchronising) is in place and operates correctly.	Yes / No*
The Interface Protection settings have been checked and comply with EREC G99.	Yes / No*
PGMs successfully synchronise with the DNO's Distribution Network without causing significant voltage disturbance.	Yes / No*
PGMs successfully run in parallel with the DNO's Distribution Network without tripping and without causing significant voltage disturbances.	Yes / No*
PGMs successfully disconnect without causing a significant voltage disturbance, when they are shut down.	Yes / No*
Interface Protection operates and disconnects the PGMs quickly (within 1s) when a suitably rated switch, located between the PGMs and the DNO's incoming connection, is opened.	Yes / No*
PGM(s) remain disconnected for at least 20s after switch is reclosed.	Yes / No*
Loss of tripping and auxiliary supplies Where applicable, loss of supplies to tripping and protection relays results in either PGM lockout or an alarm to a 24hr manned control centre.	Yes / No*
Balance of Multiple Single Phase PGMs Confirm that design of the Customer's Installation has been carried out to limit output power imbalance to below 16 A per phase, as required by EREC G99.	Yes / No*
Additional comments / observations:	
Declaration – to be completed by Generator or Generator's Appointed Technical Representative	
I declare that the Type A PGMs and the installation comply with the requirements of EREC G99 (or ERG59 or ERG83 in the case of pre-existing PGMs at the installation) and the commissioning checks detailed in A.1 and B.3* have been successfully completed. *deleted if not applicable i.e. the Interface Protection is Type Tested	
Name:	
Signature:	Date:
Position:	
Declaration – to be completed by DNO Witnessing Representative	
I confirm that I have witnessed the tests in this document on behalf of _____ and that the results are an accurate record of the tests	
Name:	
Signature:	Date:

Appendix A.4 Type A Compliance Verification Report

Form (C): Compliance Verification Report			
Type Approval and Manufacturer declaration of compliance with the requirements of G99. If the PGM is Fully Type Tested and registered with the Energy Networks Association (ENA) Type Test Verification Report Register, the Installation Document should include the Type Test Reference Number, and this form does not need to be submitted. Where the PGM is not registered with the ENA Type Test Verification Report Register or is not Fully Type Tested this form (all or in parts) needs to be completed and provided to the DNO , to confirm that the PGM has been Tested to satisfy the requirements of this EREC G99.			
Type Tested Reference Number			
PGM technology			
Manufacturer name			
Address			
Tel		Fax	
E:mail		Web site	
Registered Capacity, use separate sheet if more than one connection option.	Connection Option		
		kW single phase, single, split or three phase system	
		kW three phase	
		kW two phases in three phase system	
		kW two phases split phase system	
Manufacturer compliance declaration. - I certify that all products supplied by the company with the above Type Tested reference number will be manufactured and tested to ensure that they perform as stated in this document, prior to shipment to site and that no site modifications are required to ensure that the product meets all the requirements of G99.			
There are three options for Type Testing: (1) Fully Type Tested , (2) Partially Type Tested , (3) one off installation. The check box below indicates which tests in this Form have been completed for each of the options. With the exception of Fully Type Tested PGMs tests marked with * may be carried out at the time of commissioning.			
	Tested option:	1. Fully Type Tested	2. Partially Type Tested
		3. One Off Man. Info.	
0. Fully Type Tested			
1. Operating Range			
2. PQ – Harmonics			
3. PQ – Voltage Fluctuation and Flicker			
4. PQ – DC Injection			
5. PQ – Power Factor (PF)			
6. Protection – Frequency Test *			
7. Protection – Voltage Test *			
8. Protection – Loss of Mains Test *			
9. Protection – Frequency Change, Vector Shift Stability Test *			
10. Protection – Frequency Change, RoCoF Stability Test*			
11. Protection – LFSM-O Test			
12. Protection – Power Output with Falling Frequency Test			
13. Protection – Reconnection Timer			
14. Fault Level Contribution			
15. Self-monitoring Solid State Switch			
Document reference for Manufacturers' Information :			
Signed		On behalf of	
Note that testing can be done by the Manufacturer of an individual component or by an external test house. Where parts of the testing are carried out by persons or organisations other than the Manufacturer then that person or organisation shall keep copies of all test records and results supplied to them to verify that the testing has been carried out by people with sufficient technical competency to carry out the tests.			

Type Test Verification Report – Tests

1. Operating Range: Two tests should be carried with the **Power Generating Module** operating at **Registered Capacity** and connected to a grid simulation set. The power supplied by the primary source shall be kept stable within $\pm 5\%$ of the Apparent Power value set for the entire duration of each test sequence.

Frequency, voltage and Active Power measurements at the output terminals of the **Power**

Generating Module shall be recorded every second.

The **Interface Protection** shall be disabled during the tests.

Test 1

Voltage = 85% of nominal (195.5 V)

Frequency = 47.5 Hz

Power factor = 1

Period of test 90 minutes

Operation at reduced power is allowed where Real Power \geq 0.85 Apparent Power

Test 2

Voltage = 110% of nominal (253 V).

Frequency = 51.5 Hz

Power factor = 1

Period of test 90 minutes

Automatic adjustment to reduce power in the case of over-frequency shall be disabled

Test 3

Voltage = 110% of nominal (253 V).

Frequency = 52.0 Hz

Power factor = 1

Period of test 15 minutes

2. Power Quality – Harmonics: These tests should be carried out as specified in BS EN 61000-3-2. The chosen test should be undertaken with a fixed source of energy at two power levels a) between 45 and 55% and b) at 100% of **Registered Capacity**.

The test should be carried out on a single **Power Generating Module**. The results need to comply with the limits of table 1 of BS EN 61000-3-2.

Power Generating Module tested to BS EN 61000-3-2

Power Generating Module rating per phase (rpp)				kW		
Harmonic	At 45-55% of Registered Capacity		100% of Registered Capacity			
	Measured Value MV in Amps		Measured Value MV in Amps		Limit in BS EN 61000-3-2 in Amps	Higher limit for odd harmonics 21 and above
2					1.080	
3					2.300	
4					0.430	
5					1.140	
6					0.300	
7					0.770	
8					0.230	
9					0.400	
10					0.184	
11					0.330	
12					0.153	
13					0.210	
14					0.131	
15					0.150	
16					0.115	
17					0.132	
18					0.102	

19					0.118	
20					0.092	
21					0.107	0.160
22					0.084	
23					0.098	0.147
24					0.077	
25					0.090	0.135
26					0.071	
27					0.083	0.124
28					0.066	
29					0.078	0.117
30					0.061	
31					0.073	0.109
32					0.058	
33					0.068	0.102
34					0.054	
35					0.064	0.096
36					0.051	
37					0.061	0.091
38					0.048	
39					0.058	0.087
40					0.046	

Note the higher limits for odd harmonics 21 and above are only allowable under certain conditions, if these higher limits are utilised please state the exemption used as detailed in part 6.2.3.4 of BS EN 61000-3-2 in the box below.

3. Power Quality – Voltage fluctuations and Flicker: These tests should be undertaken in accordance with EREC G99 [Appendix A8 A.8.4.3](#).

	Starting			Stopping		Running		
	d max	d c	d(t)	d max	d c	d(t)	P st	P It 2 hours
Measured Values at test impedance								
Normalised to standard impedance								
Normalised to required maximum impedance								
Limits set under BS EN 61000-3-11	4%	3.3%	3.3%	4%	3.3%	3.3%	1.0	0.65
Test	R		Ω	XI			Ω	

Impedance						
Standard Impedance	R	0.24 * 0.4 ^	Ω	XI	0.15 * 0.25 ^	Ω
Maximum Impedance	R		Ω	XI		Ω
Applies to three phase and split single phase Power Generating Modules .						
^ Applies to single phase Power Generating Module and Power Generating Modules using two phases on a three phase system						
For voltage change and flicker measurements the following formula is to be used to convert the measured values to the normalised values where the power factor of the generation output is 0.98 or above.						
Normalised value = Measured value*reference source resistance/measured source resistance at test point						
Single phase units reference source resistance is 0.4 Ω						
Two phase units in a three phase system reference source resistance is 0.4 Ω						
Two phase units in a split phase system reference source resistance is 0.24 Ω						
Three phase units reference source resistance is 0.24 Ω						
Where the power factor of the output is under 0.98 then the XI to R ratio of the test impedance should be close to that of the Standard Impedance.						
The stopping test should be a trip from full load operation.						
The duration of these tests need to comply with the particular requirements set out in the testing notes for the technology under test. Dates and location of the test need to be noted below						
Test start date			Test end date			
Test location						
4. Power quality – DC injection: The tests should be carried out on a single Generating Unit . Tests are to be carried out at three defined power levels ±5%. At 230V a 2kW single phase inverter has a current output of 8.7A so DC limit is 21.75mA, a 10kW three phase inverter has a current output of 43.5A at 230V so DC limit is 108.75mA.						
Test power level	20%	50%	75%	100%		
Recorded value in Amps						
as % of rated AC current						
Limit	0.25%	0.25%	0.25%	0.25%		
5. Power Quality – Power factor: The tests should be carried out on a single Power Generating Module . Tests are to be carried out at three voltage levels and at Registered Capacity . Voltage to be maintained within + or – 1.5% of the stated level during the test.						
	216.2V		230V		253V	
Measured value						
Limit	>0.95		>0.95		>0.95	
6. Protection – Frequency tests: These tests should be carried out in accordance with the notes in EREC G99 Appendix A.8, A.8.2.3 .						
Function	Setting		Trip test		"No trip tests"	
	Frequency	Time delay	Frequency	Time delay	Frequency /time	Confirm no trip
U/F stage 1	47.5Hz	20s			47.7Hz 25s	
U/F stage 2	47Hz	0.5s			47.2Hz 19.98s	
					46.8Hz 0.48s	
O/F stage 1	52Hz	0.5s			51.8Hz 89.98s	
					52.2Hz 0.48s	
7. Protection – Voltage tests: These tests should be carried out in accordance with EREC G99 Appendix A.8, A.8.2.2 .						
Function	Setting		Trip test		"No trip tests"	
	Voltage	Time delay	Voltage	Time delay	Voltage /time	Confirm no trip
U/V stage 1	200.1V	2.5s			204.1V 3.5s	
U/V stage 2	184V	0.5s			188V 2.48s	
					180V 0.48s	
O/V stage	262.2V	1.0s			258.2V	

1					2.0s	
O/V stage 2	273.7V	0.5s			269.7V 0.98s	
					277.7V 0.48s	
Note for Voltage tests the Voltage required to trip is the setting $\pm 3.45V$. The time delay can be measured at a larger deviation than the minimum required to operate the protection. The No trip tests need to be carried out at the setting $\pm 4V$ and for the relevant times as shown in the table above to ensure that the protection will not trip in error.						
8. Protection – Loss of Mains test: The tests are to be carried out at three output power levels plus or minus 5%, an alternative for inverter connected Power Generating Modules can be used instead. PV Inverters shall be tested in accordance with BS EN 62116.						
To be carried out at three output power levels with a tolerance of plus or minus 5% in Test Power levels.						
Test Power	10%	55%	100%	10%	55%	100%
Balancing load on islanded network	95% of Reg Cap	95% of Reg Cap	95% of Reg Cap	105% of Reg Cap	105% of Reg Cap	105% of Reg Cap
Trip time. Limit is 0.5 seconds						
For Multi phase Power Generating Modules confirm that the device shuts down correctly after the removal of a single fuse as well as operation of all phases.						
Test Power	10%	55%	100%	10%	55%	100%
Balancing load on islanded network	95% of Reg Cap	95% of Reg Cap	95% of Reg Cap	105% of Reg Cap	105% of Reg Cap	105% of Reg Cap
Trip time. Ph1 fuse removed						
Test Power	10%	55%	100%	10%	55%	100%
Balancing load on islanded network	95% of Reg Cap	95% of Reg Cap	95% of Reg Cap	105% of Reg Cap	105% of Reg Cap	105% of Reg Cap
Trip time. Ph2 fuse removed						
Test Power	10%	55%	100%	10%	55%	100%
Balancing load on islanded network	95% of Reg Cap	95% of Reg Cap	95% of Reg Cap	105% of Reg Cap	105% of Reg Cap	105% of Reg Cap
Trip time. Ph3 fuse removed						
Note for technologies which have a substantial shut down time this can be added to the 0.5 seconds in establishing that the trip occurred in less than 0.5s. Maximum shut down time could therefore be up to 1.0 seconds for these technologies.						
Indicate additional shut down time included in above results.						ms
For Inverters tested to BS EN 62116 the following sub set of tests should be recorded in the following table.						
Test Power and imbalance	33% -5% Q Test 22	66% -5% Q Test 12	100% -5% P Test 5	33% +5% Q Test 31	66% +5% Q Test 21	100% +5% P Test 10
Trip time. Limit is 0.5s						
9. Protection – Frequency change, Vector Shift Stability test. This test should be carried out in accordance with Appendix A.8, A.8.2.7 .						
	Start Frequency	Change	End Frequency	Confirm no trip		
Positive Vector Shift	49.5Hz	+50 degrees				
Negative Vector Shift	50.5Hz	- 50 degrees				
10. Protection – Frequency change, RoCoF Stability test: This test should be carried out in accordance with Appendix A.8, A.8.2.7 .						
Ramp range	Test frequency ramp:		Test Duration	Confirm no trip		
49.0Hz to 51.0Hz	+0.95Hzs ⁻¹		2.1s			
51.0Hz to 49.0Hz	-0.95Hzs ⁻¹		2.1s			
11. Protection – Limited Frequency Sensitive Mode – Over frequency test: The test should be carried out using the specific threshold frequency of 50.4 Hz and droop of 10%.						
Simulated: The tests for providing evidence of the frequency dependent active power feed-in of the Power Generating Module shall be carried out on a network simulator.						
Alternatively the tests can be carried out by one of the following methods:						
<ul style="list-style-type: none"> adjusting the input signals on the control unit of the Power Generating Module; adjusting the limit values (set values) in the control unit of the Power Generating Module if the manufacturer declares the full functionality of the Power Generating Module control and feed-in at all required operating frequencies (47.5 Hz to 51.5 Hz). 						
Each frequency step should be maintained for at least one minute						
Test sequence at Registered Capacity >80%	Measured Active Power Output	Frequency	Primary Power Source	Active Power Gradient		
Step a) 50.00Hz ± 0.01 Hz				-		
Step b) 50.45Hz ± 0.05 Hz				-		
Step c) 50.70Hz ± 0.10 Hz				-		

Step d) 51.15Hz ±0.05Hz				-	
Step e) 50.70Hz ±0.10Hz				-	
Step f) 50.45Hz ±0.05Hz				-	
Step g) 50.00Hz ±0.01Hz					
Test sequence at Registered Capacity 40% - 60%	Measured Power Output	Active	Frequency	Primary Power Source	Active Power Gradient
Step a) 50.00Hz ±0.01Hz					-
Step b) 50.45Hz ±0.05Hz					-
Step c) 50.70Hz ±0.10Hz					-
Step d) 51.15Hz ±0.05Hz					-
Step e) 50.70Hz ±0.10Hz					-
Step f) 50.45Hz ±0.05Hz					-
Step g) 50.00Hz ±0.01Hz					
12. Protection – Power output with falling frequency test					
Tests should prove that the Power Generating Module does not disconnect when the frequency is changed and that the Power Generating Module does not reduce output power during test (a) or (b). The Power Generating Module output power reduction must be less or equal to that allowed in para 11.2.4 during test (c).					
Test sequence	Measured Power Output	Active	Frequenc y	Primary power source	
Test a) 50Hz ± 0.01Hz					
Test b) Point between 49.5 Hz and 49.6 Hz					
Test c) Point between 47.5 Hz and 47.6 Hz					
NOTE: The operating point in Test (b) and (c) shall be maintained for at least 5 minutes					
13. Protection – Re-connection timer.					
Test should prove that the reconnection sequence starts after a minimum delay of 20 seconds for restoration of voltage and frequency to within the stage 1 settings of table 2.					
Time delay setting	Measured delay	Checks on no reconnection when voltage or frequency is brought to just outside stage 1 limits of table 2.			
		At 266.2V	At 196.1V	At 47.4Hz	At 51.6Hz
Confirmation that the SSEG does not re- connect.					
14. Fault level contribution: These tests shall be carried out in accordance with EREC G99 Appendix A.8, A.8.4.6 and A.8.4.7.					
For machines with electro-magnetic output			For Inverter output		
Parameter	Symbol	Value	Time after fault	V ol ts	Amps
Peak Short Circuit current	i_p		20ms		
Initial Value of aperiodic current	A		100ms		
Initial symmetrical short-circuit current*	I_k		250ms		
Decaying (aperiodic) component of short circuit current*	i_{DC}		500ms		
Reactance/Resistance Ratio of source*	X/R		Time to trip		In seconds
For rotating machines and linear piston machines the test should produce a 0s – 2s plot of the short circuit current as seen at the Power Generating Module terminals.					
* Values for these parameters should be provided where the short circuit duration is sufficiently long to enable interpolation of the plot					
15. Self-Monitoring solid state switching: No specified test requirements. Refer to EREC G99 Appendix A.8, A.8.4.8.			Yes/or NA		
It has been verified that in the event of the solid state switching device failing to disconnect the Power Generating Module , the voltage on the output side of the switching device is reduced to a value below 50 volts within 0.5 seconds.					
Additional comments					

Appendix A.5 Emerging Technologies and other Exceptions

Emerging Technologies

Ofgem have published details of **Micro-generators** which are classified as emerging technologies in **Great Britain** in their document “Requirement for generators – ‘emerging technology’ decision document”, 17 May 2017. The list is reproduced in the table below for reference:

Manufacturer	Micro-generator
Baxi	‘Baxi Ecogen’ generators (the specific products are the Baxi Ecogen 24/1.0, Baxi Ecogen 24/1.0 LPG and Baxi Ecogen System).
KD Navien	KD Navien stirling engine m-CHP (Hybrigen SE) (the specific products that use this power generating module are the ‘NCM-1130HH – 1 kWel’ and the ‘NCM-2030HH – 2 kWel’).
OkoFEN	Pellematic Smart_e
SenerTec	Dachs Stirling SE Erdgas and Dachs Stirling SE Flussiggas

For **Micro-generators** classified as an emerging technology at the time of their connection to a **DNO’s Distribution Network**, the following sections of EREC G99 do not apply.

- The frequency withstand capability in 11.2.1;
- The rate of change of frequency requirements in 11.2.3;
- The constant **Active Power** output requirement in 11.2.4;
- The **Limited Frequency Sensitive Mode – Overfrequency** requirements in 11.2.5;
- The **Interface Protection** settings in 10.6.7.

Performance requirements for these emerging technologies and other exemptions will be within the protection setting limits in Table 10.1 in Section 10.6.7 of this EREC G99, but they do not have to extend to the full ranges of the protection requirements. For example if a technology can only operate in a frequency range from 49.5Hz to 50.5 Hz and outside of this it will disconnect from the **Distribution Network**, this technology would still be deemed to meet this EREC G99.

Emerging technology classification may be revoked as detailed in the Ofgem document “Requirement for generators – ‘emerging technology’ decision document”, 17 May 2017.

Micro-generators classified as emerging technologies and connected to the **Distribution Network** prior to the date of revocation of that classification as an emerging technology shall be considered to be existing generators, and this appendix continues to apply.

Micro-Generators <800W

For **Micro-generators** with a **Registered Capacity** of less than 800W the following sections of EREC G99 do not apply:

- The constant **Active Power** output requirement in 11.2.4;
- The **Limited Frequency Sensitive Mode – Overfrequency** requirements in 11.2.5;

Storage

For electricity storage devices the following sections of EREC G99 do not apply:

Type A

- The constant **Active Power** output requirement in 11.2.4;
- The **Limited Frequency Sensitive Mode – Overfrequency** requirements in 11.2.5;

Type B

- The constant **Active Power** output requirement in 12.2.4;
- The **Limited Frequency Sensitive Mode – Overfrequency** requirements in 12.2.5;
- The **Fault Ride Through** requirements of 12.3 and 12.6

Type C and Type D

- The constant **Active Power** output requirement in 13.2.3;
- The **Limited Frequency Sensitive Mode – Overfrequency** requirements in 13.2.4;
- The **Limited Frequency Sensitive Mode – Underfrequency** requirements in 13.2.5;
- **Frequency Sensitive Mode** in 13.2.6

- The **Fault Ride Through** requirements of 13.4 and 13.7

Short Term Paralleling

For **Power Generating Modules** that operate in parallel with the **Distribution Network** under an infrequent short-term parallel operation mode the following sections of EREC G99 do not apply:

All types

Section 9.1 to 9.5, 9.7

Section 10

Type A

- All of Section 11

Type B

- All of Section 12

Type C

All of Section 123

Appendix A.6 Example calculations to determine if unequal generation across different phases is acceptable or not

A **Customer Installation** might have 12kW of PV and a 3kW CHP plant. Due to the areas of roof available the PV plant comprises 2 by 4.5kW **Inverters** and a 3kW **Inverter**.

A. The following connection would be deemed acceptable:

- Ph 1 4.5kW PV
- Ph 2 3kW PV plus 3kW CHP
- Ph 3 4.5kW PV

This would lead to:

- 1.5kW imbalance with CHP at zero output
- 1.5kW imbalance with CHP and PV at maximum output
- 3kW imbalance with CHP at maximum output and PV at zero output.

All of which are below the 16A imbalance limit.

B. The following alternative connection for the same plant would be deemed unacceptable:

- Ph1 4.5kW PV plus 3kW CHP
- Ph 2 3kW PV
- Ph3 4.5kW PV

This is not acceptable as at full output Ph1 would have 4.5kW more output than Ph2 and this exceeds the 16A limit described above even though on an individual technology basis the limit of 16A is not exceeded.

If a **Customer Installation** has a single technology installed which has **PGMs** with different output patterns for example PV mounted on roofs facing different directions then they should be regarded separately

(For these cases the assumption is that in the morning the east roof would produce full output and the west roof zero output with the opposite in the afternoon. Whilst this might not be strictly true the simplification makes the calculations much simpler)

A. The following connection would be deemed acceptable.

- Ph 1 6kW east roof 6kW west roof
- Ph 2 6kW east roof 6kW west roof
- Ph 3 5kW east roof 5kW west roof

B. The following alternative connection for the same plant would be deemed unacceptable.

- Ph1 12kW east roof
- Ph2 5kW east roof 5kW west roof
- Ph 3 12kW west roof

This is not acceptable as Ph 1 would produce more than Ph 3 in the morning and in the afternoon Ph 3 would produce more than Ph 1 in each case by a margin greater than 16A.

Appendix A.7 Non-Standard private LV networks calculation of appropriate protection settings

The standard over and under voltage settings for LV connected PGMs have been developed based on a nominal LV voltage of 230V. Typical DNO practice is to purchase transformers with a transformer winding ratio of 11 000:433, with off load tap changers allowing the nominal winding ratio to be changed over a range of plus or minus 5% and with delta connected HV windings. Where a DNO provides a connection at HV and the Customer uses transformers of the same nominal winding ratio and with the same tap selection as the DNO then the standard LV settings in Table 2 can be used for PGMs connected to the Customers LV network. Where a DNO provides a connection at HV and the Customers transformers have different nominal winding ratios, and he chooses to take the protection reference measurements from the LV side of the transformer, then the LV settings stated in Table 2 should not be used without the prior agreement of the DNO. Where the DNO does not consider the standard LV settings to be suitable, the following method shall be used to calculate the required LV settings based on the HV settings stated in table 2.

Identify the value of the transformers nominal winding ratio and if using other than the nominal tap, increase or decrease this value to establish a LV system nominal value based on the transformer winding ratio and tap position and the DNOs declared HV system nominal voltage.

For example a Customer is using a 11 000V to 230/400V transformer and it is proposed to operate it on tap 1 representing an increase in the high voltage winding of +5% and the nominal HV voltage is 11 000V.

$$V_{LVsys} = V_{LVnom} \times V_{HVnom} / V_{HVtap}$$

$$V_{LVsys} = 230 \times 11\,000 / 11\,550 = 219V$$

Where:

V_{LVsys} - LV system voltage

V_{LVnom} - LV system nominal voltage (230V)

V_{HVnom} - HV system nominal voltage (11 000V)

V_{HVtap} - HV tap position

The revised LV voltage settings required therefore would be;

OV stage 1	=	219x1.1=	241V
OV stage 2	=	219x1.13	= 247.5V
UV stage 1	=	219x0.87	= 190.5V
UV stage 2	=	219x0.8=	175V

The time delays required for each stage are as stated in table 2.

Where PGMs are designed with balanced 3 phase outputs and no neutral is required then phase to phase voltages can be used instead of phase to neutral voltages.

This approach does not lend itself to Fully Type Tested PGMs and should only be used by prior arrangement with the host DNO. Where all other requirements of EREC G99 would allow the Generation Unit to be Fully Type Tested, the Manufacturer may produce a declaration in a similar format to Appendix 3. From (C) for presentation to the DNO by the Installer, stating that all Generating Units produced for a particular Power Station comply with the revised over and under voltage settings. All other required data should be provided as for Fully Type Tested Generating Units. This declaration should make reference to a particular PGM and its declared LV system voltage. These documents should not be registered on the ENA web site as they will not be of use to other Installers who will have to consult with the Manufacturer and DNO to agree settings for each particular Power Station.

Appendix A.8 Requirements for Type Testing Power Generating Modules

Comment [MK1]: Note that this appendix needs to be expanded/modified to cover synchronous machines up to 1MW

This Appendix describes a methodology for obtaining type certification or type verification for **PGMs** which are directly connected to the **Distribution Network** or for **Generating Units** which are connected to the **Distribution Network** via an **Inverter**.

Typically, all interface functions are contained within an **Inverter** and in such cases it is only necessary to have the **Inverter Type Tested**. Alternatively, a package of specific separate parts of equivalent function may also be **Type Tested** but the completed **PGM's Interface Protection** must not rely on interconnection using cables which could be terminated incorrectly on site i.e. the interconnections must be made by plug and socket which the **Manufacturer** has made and tested prior to delivery to site.

This Appendix is primarily designed for the testing of three phase **PGMs**. However, where practicable, a single phase, or split phase test may be carried out if it can be shown that it will produce the equivalent results.

This Appendix applies for **PGMs** either with or without load management or energy storage systems which are connected on the **PGM** side of the **Inverter**.

A.8.1 CE Marking and Certification

The type verification procedure requires that the **PGM** interface be certified to the relevant requirements of the applicable Directives before the **PGM** can be labelled with a CE mark. Where the protection control is to be provided as a separate device, this must also be **Type Tested** and certified to the relevant requirements of the applicable Directives before it can be labelled with a CE mark.

The **PGM's Interface Protection** shall satisfy the requirements of all of the following standards. Where these standards have more than one part, the requirements of all such parts shall be satisfied, so far as they are applicable.

BS EN 61000 (Electromagnetic Standards)
 BS EN 60255 (Electrical Relays)
 BS EN 61810 (Electrical Elementary Relays)
 BS EN 60947 (Low Voltage Switchgear and Control gear)
 BS EN 60044 (Instrument Transformers)

Currently there are no harmonised functional standards that apply to the **PGM's Interface Protection**. Consequently, in cases where power electronics is used for energy conversion along with any separate **Interface Protection** unit they will need to be brought together and tested as a complete **PGM** as described in this EREC G99, and recorded in format similar to that shown in **Appendix A.4 (Form C)**. Where the **Interface Protection** is physically integrated within the overall **PGM** control system, the functionality of the **Interface Protection** unit should not be compromised by any failure of other elements of the control system (fail safe).

A.8.2 Type Verification Functional Testing of the Interface Protection

Type testing is the responsibility of the **Manufacturer**.

The type testing can be done by the **Manufacturer** of an individual component or by an external test house, or by the supplier of the complete system, or any combination of them as appropriate.

The type testing will verify that the operation of the **Interface Protection** shall result:

- a) in the safe disconnection of the **PGM** from the **DNO's Distribution Network** in the event that the protection settings specified in Table 2 are exceeded; and
- b) in the remaining connected to the **DNO's Distribution Network** while **Distribution Network** conditions are:
 - a. within the envelope specified by the settings plus and minus the tolerances specified for equipment operation in Table 10.1; and
 - b. within the trip delay settings specified in Table 10.1.

Wherever possible the **Type Testing** of an **Inverter** designed for a particular type of **PGM** should be proved under normal conditions of operation for that technology (unless otherwise noted).

This will require that the chosen **PGM Interface Protection** is either already incorporated into the **Inverter** or that the discrete device is connected to the **Inverter** for the loss of mains protection test. Testing the voltage and frequency functions may be carried out on the discrete protection device independently or on the **Inverter** complete.

In either case it will be necessary to verify that a protection operation will disconnect the **Generator** from the **DNO's Distribution System**.

A.8.2.1 Disconnection times

In some systems it may be safer and more convenient to test the time delay and the

disconnection time separately. This will allow the time delay to be measured in a test environment (in a similar way as you could test a protection relay). The disconnection time can be measured in the **PGMs** normal operation, allowing accurate measurement with correct inertia and prime mover characteristics. This is permitted providing the total disconnection time does not exceed the time delay setting plus 0.5s. When measuring the shutdown time, 5 shutdowns should be initiated, and the average time recorded.

A.8.2.2 Over / Under Voltage

The **PGM** shall be tested by operating the or a simulator and the **Inverter** or Controller in parallel with a variable **AC** test supply, see [figure A.8.1](#). Correct protection and ride-through operation shall be confirmed during operation of the **PGM**. The set points for over and under voltage at which the **PGM** disconnects from the supply will be established by varying the **AC** supply voltage.

To establish a trip voltage, the test voltage should be applied in steps of $\pm 0.5\%$ or less, of the nominal voltage for a duration that is longer than the trip time delay, for example 1 second in the case of a delay setting of 0.5 second starting at least 4V below or above the setting. The test voltage at which this trip occurred is to be recorded. Additional tests just above and below the trip voltage should be undertaken to show that the test is repeatable and the figure at which a repeatable trip occurs should be recorded on the type verification test report [Appendix A.4 \(Form C\)](#) of this Engineering Recommendation.

To establish the trip time, the test voltage should be applied starting from 4V below or above the recorded trip voltage and should be changed to 4V above or below the recorded trip voltage in a single step. The time taken from the step change to the **PGM** tripping is to be recorded on the type verification test report [Appendix A.4 \(Form C\)](#) of this Engineering Recommendation.

To establish correct ride-through operation, the test voltage should be applied at each setting plus or minus 4V and for the relevant times shown in the table in [Appendix A.4 \(Form C\)](#).

For example to test overvoltage setting stage 1 which is required to be set at nominally 262.2V the circuit should be set up as shown below and the voltage adjusted to 254.2 volts. The **PGM** should then be powered up to export a measurable amount of energy so that it can be confirmed that the **PGM** has ceased to output energy. The variable voltage supply is then increased in steps of no more than 0.5% of nominal (1.15V) maintaining the voltage for at least 1.5 seconds (trip time plus 0.5 seconds) at each voltage level. At each voltage level confirmation that the **PGM** has not tripped after the time delay is required to be taken. At the voltage level at which a trip occurs then this should be recorded as the provisional trip voltage. Additional tests just below and if necessary just above the provisional trip voltage will allow the actual trip voltage to be established on a repeatable basis. This value should be recorded. For the sake of this example the actual trip level is assumed to have been established as being 261V. The variable voltage supply should be set to 257V the **PGM** set to produce a measurable output and then the voltage raised to 265V in a single step. The time from the step change to the output of the **PGM** falling to zero should be recorded as the trip time.

The **PGM** then needs to operate at 4 volts below the nominal overvoltage stage 1 setting which is 258.2V for a period of at least 2 seconds without tripping and while producing a measurable output. This can be confirmed as a no trip in the relevant part of [Appendix 3, Form C](#). The voltage then needs to be stepped up to the next level of 269.7V for a period of 0.98 seconds and then back to 258.2V during which time the output of the relay should continue with no interruption though it may change due to the change in voltage, this can be recorded as a no trip for the second value. The step up and step down test needs to be done a second time with a max value of 277.7V and with a time of 0.48 seconds. The **PGM** is allowed to shut down during this period to protect its self as allowed by note 3 of Table 2 of this document, but it must resume production again when the voltage has been restored to 258.2V or it may continue to produce an output during this period. There is no defined time for resumption of production but it must be shown that restart timer has not operated so it must begin producing again in less than 20 seconds.

The "No-trip tests" need to be carried out at the relevant values and times as shown in the tables in [Appendix A.4 \(Form C\)](#) to ensure that the protection will not trip in error.

Note that this philosophy should be applied to the under voltage, over and under frequency, RoCoF and Vector shift stability tests which follow.

Note:

- (1) The frequency required to trip is the setting plus or minus 0.1Hz
- (2) Measurement of operating time should be measured at a value of 0.2Hz (suggestion – 2 x tolerance) above/below the setting to give "positive" operation
- (3) The "No trip tests" need to be carried out at the relevant values and times as shown in the table above to ensure that the protection will not trip in error.

Figure A.8.1. PGM Test set up – Over / Under Voltage

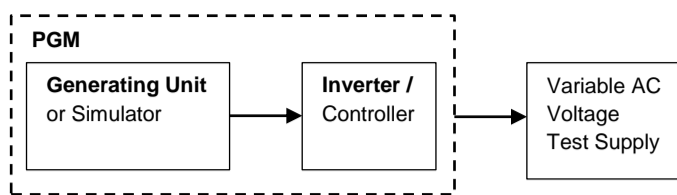

A.8.2.3 Over / Under Frequency

The **PGM** shall be tested by operating the **Generating Unit** or a simulator and the **Inverter** or Controller in parallel with a low impedance, variable frequency test supply system, see figure A.8.2. Correct protection and ride-through operation should be confirmed during operation of the **PGM**. The set points for over and under frequency at which the **PGM** system disconnects from the supply will be established by varying the test supply frequency.

To establish a trip frequency, the test frequency should be applied in a slow ramp rate of less than 0.1Hz/second, or if this is not possible in steps of 0.05Hz for a duration that is longer than the trip time delay, for example 1 second in the case of a delay setting of 0.5 second. The test frequency at which this trip occurred is to be recorded. Additional tests just above and below the trip frequency should be undertaken to show that the test is repeatable and the figure at which a repeatable trip occurs should be recorded on the type verification test report [Appendix A.4 \(Form C\)](#) of this EREC G99.

To establish the trip time, the test frequency should be applied starting from 0.3Hz below or above the recorded trip frequency and should be changed to 0.3Hz above or below the recorded trip frequency in a single step. The time taken from the step change to the **PGM** tripping is to be recorded on the type verification test report [Appendix A.4 \(Form C\)](#) of this Engineering Recommendation. It should be noted that with some loss of mains detection techniques this test may result in a faster trip due to operation of the loss of mains protection. To avoid this it is necessary to establish an accurate frequency for the trip to enable the use of a much smaller step change to initiate the trip and establish a trip time. This may require the test to be repeated several times to establish that the time delay is correct.

To establish correct ride-through operation, the test frequency should be applied at each setting plus or minus 0.2Hz and for the relevant times shown in the table in [Appendix A.4 \(Form C\)](#).

Figure A.8.2. Test set up – Over / Under Frequency

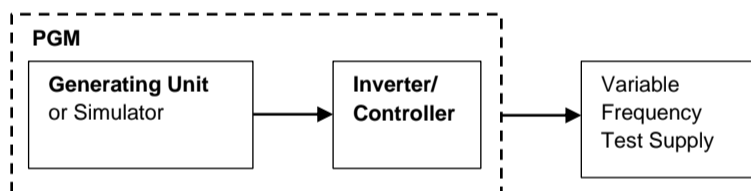

A.8.2.4 Loss of Mains Protection – Inverter connected machines

The tests should be carried out in accordance with BS EN 62116 and a subset of results should be recorded as indicated in the Protection – Loss of Mains test section of the **Type Test** declaration [Appendix A.4 \(Form C\)](#).

For Multi phase **Generating Units** they should be operated at part load while connected to a network running at about 50Hz and one phase only shall be disconnected with no disturbance to the other phases. The **Generating Unit** should trip within 1 second. The test needs to be repeated with each phase disconnected in turn while the other two phases remain in operation and the results recorded in the Type Test declaration.

A.8.2.5 Loss of Mains Protection, Directly connected machines

The resonant test circuit specified in this test has been designed to model the interaction of the directly coupled **PGM** under test with the local load including multiple directly coupled connected **PGMs** in parallel.

The directly coupled **PGM** shall be connected to a network combining a resonant circuit with a Q factor of >0.5 and a variable load. The value of the load is to match the directly coupled **PGM** output. To facilitate the test for LoM there shall be a switch placed between the test load/directly coupled **PGM** combination and the **DNO's Distribution Network**, as shown below:

Figure A.8.3 Generator Test set up - Loss of Mains

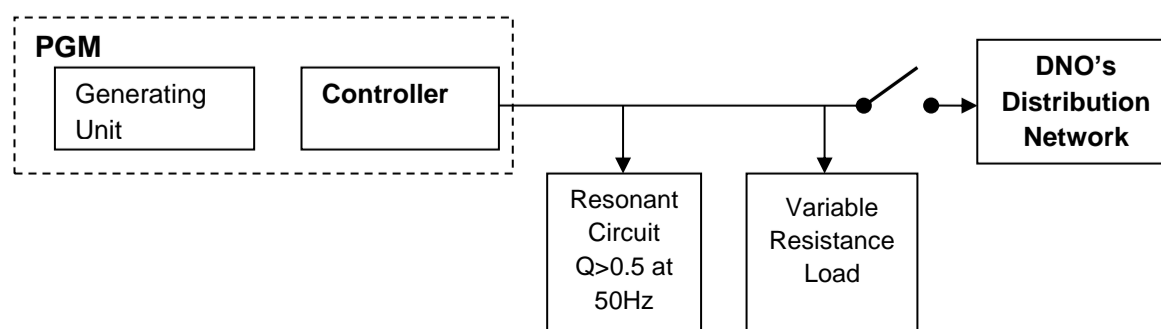

The directly coupled **PGM** is to be tested at three levels of the directly coupled **PGMs** output power: 10%, 55% and 100% and the results recorded on the **Type Test** declaration **Appendix A.4 (Form C)**. For each test the load match is to be within $\pm 5\%$. Each test is to be repeated five times.

Load match conditions are defined as being when the current from the directly coupled **PGM** meets the requirements of the test load ie there is no export or import of supply frequency current to or from the **DNO's Distribution Network**.

The tests will record the directly coupled **PGMs** output voltage and frequency from at least 2 cycles before the switch is opened until the protection system operates and disconnects itself from the **DNO's Distribution Network**, or for five seconds whichever is the lower duration.

The time from the switch opening until the protection disconnection occurs is to be measured and must comply with the requirements in **Table 10.1**.

Multi phase **PGMs** should be operated at part load while connected to a network running at about 50Hz and one phase only shall be disconnected with no disturbance to the other phases. The **PGM** should trip within 1s. The test needs to be repeated with each phase disconnected in turn while the other two phases remain in operation and the results recorded in the **Type Test** declaration.

A.8.2.6 Reconnection

Further tests will confirm that once the **AC** supply voltage and frequency have returned to be within the stage 1 settings specified in **Table 10.1** following an automatic protection trip operation there is a minimum time delay of 20 seconds before the **PGM** output is restored (ie before the **PGM** automatically reconnects to the **Distribution Network**).

A.8.2.7 Frequency Drift and Step Change Stability test

The tests will be carried out using the same circuit as specified in **A.8.2.3** above and following confirmation that the **PGM** has passed the under and over frequency trip tests and the under and over frequency stability tests.

Four tests are required to be carried out with all protection functions enabled including loss of mains. For each stability test the **PGM** should not trip during the test.

For the step change test the **PGM** should be operated with a measurable output at the start frequency and then a vector shift should be applied by extending or reducing the time of a single cycle with subsequent cycles returning to the start frequency. The start frequency should then be maintained for a period of at least 10 seconds to complete the test. The **PGM** should not trip during this test.

For frequency drift tests the **PGM** should be operated with a measurable output at the start frequency and then the frequency changed in a ramp function at 0.19Hz per second to the end frequency. On reaching the end frequency it should be maintained for a period of at least 10 seconds. The **Generating Unit** should not trip during this test.

A.8.2.8 Active power feed-in at under-frequency

The tests will be carried out using the same circuit as specified in **A.8.2.3** above and following confirmation that the **PGM** has passed the under and over frequency trip tests and the under and over frequency stability tests.

The **PGM** should be tested at the following frequencies:

- a) 50Hz \pm 0.01Hz
- b) Point between 49.5 Hz and 49.6 Hz
- c) Point between 47.5 Hz and 47.6 Hz

The tests should prove that the **PGM** does not disconnect when the frequency is changed and that the **PGM** does not reduce output power during test (a) or (b). The **PGM** output power reduction must be less or equal to that allowed in paragraph **11.2.4** during test (c).

The operating point in Test (b) and (c) shall be maintained for at least 5 minutes.

A.8.2.9 Power response to over-frequency

The tests will be carried out using the same circuit as specified in A.8.2.3 above and following confirmation that the **PGM** has passed the under and over frequency trip tests and the under and over frequency stability tests.

The tests for providing evidence of the frequency dependent active power feed-in of the **PGM** shall be carried out on a network simulator. Or alternatively the tests can be carried out by one of the following methods:

- adjusting the input signals on the control unit of the **PGM**;
- adjusting the limit values (set values) in the control unit of the **PGM** if the manufacturer declares the full functionality of the **PGM** control and feed-in at all required operating frequencies (47.5 Hz to 51.5 Hz).

The test should be carried out above 80% **Registered Capacity** and repeated at 40-60% **Registered Capacity** using the specific threshold frequency of 50.4 Hz and droop of 10%.

The **PGM** should be tested at the following frequencies:

- Step a) 50.00Hz \pm 0.01Hz
- Step b) 50.45Hz \pm 0.05Hz
- Step c) 50.70Hz \pm 0.10Hz
- Step d) 51.15Hz \pm 0.05Hz
- Step e) 50.70Hz \pm 0.10Hz
- Step f) 50.45Hz \pm 0.05Hz
- Step g) 50.00Hz \pm 0.01Hz

The frequency at each step should be maintained for at least one minute and the Active Power reduction in the form of a gradient determined and assessed for compliance with paragraph 11.2.4.

A.8.3 POWER QUALITY

A.8.3.1 Harmonics

The tests should be carried out as specified in BS EN 61000-3-2 and can be undertaken with a fixed source of energy at two power levels firstly between 45 and 55% and at 100% of maximum export capacity. The required supply minimum fault level should be recorded in the relevant part of Type Test declaration Appendix A.4 (Form C). If the harmonics meet the technical requirements of BS EN 61000-3-2 then the relevant alternative part of the document can be completed and there will be no need to specify the minimum fault level required.

The test must be carried out with a minimum of 2kW of rated **PGMs**. Where an individual **PGM** is smaller than 2kW it should be tested as a group. However where a **PGM** is designed to be installed singly in an installation then this can be tested alone, for example a domestic CHP unit. The maximum group size for the test is 3.68kW.

The results for all **Inverters** should be normalised to a rating of 3.68kW. The **PGM** or group shall meet the harmonic emissions of table 1 in BS EN 61000-3-2 with a scaling factor applied as follows for each harmonic current;

Table 1 current limit \times rating of **PGM** being tested (kW) per phase / 3.68

A.8.3.2 Power Factor

The test set up shall be such that the **PGM** supplies full load to the **DNO's Distribution Network** via the power factor (pf) meter and the variac as shown below in figure A.8.4. The **PGM** pf should be within the limits given in the "Protection – voltage test" in Appendix A.4 (Form C), for three test voltages 230 V -6% , 230V and 230 V $+10\%$.

Figure A.8.4 Generator Test set up – Power Factor

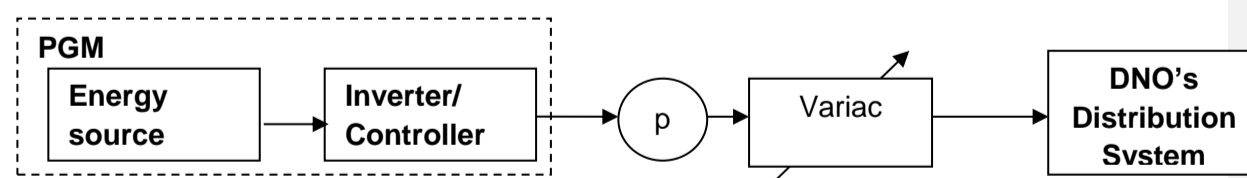

NOTE 1 For reasons of clarity the points of isolation are not shown.

NOTE 2: It is permissible to use a voltage regulator or tapped transformer to perform this test rather than a variac as shown.

A.8.4.3 Voltage Flicker

The voltage fluctuations and flicker emissions from the **Generating Unit** shall be measured in accordance with BS EN 61000-3-11 and technology specific annex. The required maximum supply impedance should be calculated and recorded in the **Type Test** declaration Appendix A.4 (Form C).

Where the **Generating Unit** meets the technical requirements of BS EN 61000-3-3 then this can be stated as an alternative and there is no need to specify the maximum supply impedance.

The test must be carried out with a minimum of 2kW of rated **PGMs**. Where an individual **PGM** is smaller than 2kW it should be tested as a group. However, where a **PGM** is designed to be installed singly in an installation then this can be tested alone, for example a domestic CHP unit. The maximum group size for the test is 3.68kW.

The **PGM** or group shall meet the required d_{max} , d_c , $d_{(t)}$, P_{st} , P_{lt} requirements of BS EN 61000-3-3 with a scaling factor applied as follows for each voltage change component.

$$d_{max}, d_c, d_{(t)}, P_{st}, P_{lt} \times \text{rating of PGM being tested (kW) per phase} / 3.68$$

The results for groups of **Inverters** should be normalised to a rating of 3.68kW and to the standard source impedance. Single **Inverters** need to be normalised to the standard source impedance, these normalised results need to comply with the limits set out in [Appendix A.4 \(Form C\)](#).

For voltage change and flicker measurements the following simplified formula is to be used to convert the measured values to the normalised values where the power factor of the generation output is 0.98 or above. Where it is less than 0.98 then compliance with the full requirements of BS EN 61000-3-3 is required.

Normalised value = Measured value \times reference source resistance/measured source resistance at test point.

And for units which are tested as a group.

Normalised value = Measured value \times reference source resistance/measured source resistance at test point \times 3.68/rating per phase.

Single phase units reference source resistance is 0.4 ohms

Two phase units in a three phase system reference source resistance is 0.4 ohms

Two phase units in a split phase system reference source resistance is 0.24 ohms

Three phase units reference source resistance is 0.24 ohms.

The stopping test should be a trip from full load generation.

The dates and location of the tests need to be noted in [Appendix A.4 \(Form C\)](#).

Note: For wind turbines, flicker testing should be carried out during the performance tests specified in IEC 61400-12-1. Flicker data should be recorded from wind speeds of 1m/s below cut-in to 1.5 times 85% of the rated power. The wind speed range should be divided into contiguous bins of 1m/s centred on multiples of 1m/s. The dataset shall be considered complete when each bin includes a minimum of 10 minutes of sampled data. The highest value of each parameter measured across the entire range of tests shall be recorded.

Note: As an alternative to type testing the **Manufacturer** of a **PGM** incorporating an **Inverter** may give a guarantee that rates of change of output do not exceed the following ramp rate limits. Output needs to ramp up at a constant rate.

This exception to site testing does not apply to devices where the output changes in steps of over 30ms rather than as a ramp function, a site test is required for these units.

- Single phase units and two phase units in a three phase system, maximum ramp up rate 333 watts per second;
- Two phase units in a split phase system and three phase units, maximum ramp up rate 860 watts per second.

It should be noted that units complying with this declaration are likely to be less efficient at capturing energy during times when the energy source is changing.

For technologies other than wind turbines, testing should ensure that the controls or automatic programs used produce the most unfavourable sequence of voltage changes.

Hydro PGMs with manually fixed output or where the output is fixed by controlling the water flow through the turbine to a steady rate, need to comply with the maximum voltage change requirements of BS EN 61000-3-2 but do not need to be tested for P_{st} or P_{lt} .

Hydro PGMs where the output is controlled by varying the load on the generator using the **Inverter** and which therefore produces variable output need to comply with the maximum voltage change requirements of BS EN 61000-3-2 and also need to be tested for P_{st} and P_{lt} over a period where the range of flows varies over the design range of the turbine with a period of at least 2 hours at each step with there being 10 steps from min flow to maximum flow. P_{st} and P_{lt} values to be recorded and normalised as per the method laid down in [Appendix A.4 \(Form C\)](#).

A.8.4.4 DC Injection

The level of **DC** injection from the **PGM** in to the **DNO's Distribution Network** shall not exceed the levels specified in paragraph 9.4.5 when measured during operation at three levels, 10%, 55% and 100% of rating with a tolerance of $\pm 5\%$ of the rating.

The DC injection requirements can be satisfied by the installation of an isolation transformer on the **AC** side of an **Inverter-connected Generating Unit**. A declaration that an isolating transformer is fitted can be made in lieu of the tests noted above.

A.8.4.5 Overcurrent Protection

Where appropriate the protection shall comply with the requirements of BS7671.

A.8.4.6 Short Circuit Current Contribution for Inverters

Inverter connected **PGMs** generally have small short circuit fault contributions however **DNO's** need to understand the contribution that they do make to system fault levels in order to determine that they can continue to safely operate without exceeding design fault levels for switchgear and other circuit components.

The following type tests shall be carried out and the results noted in **Appendix A.4 (Form C)**.

Test circuit

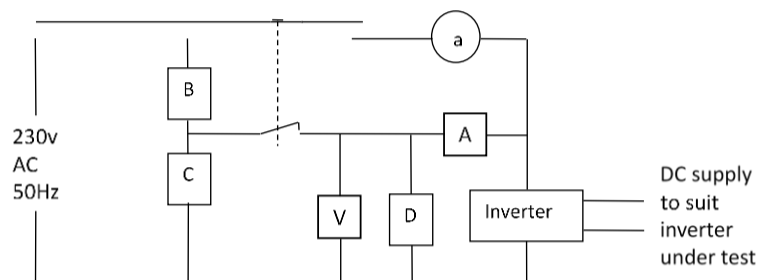

Test procedure

'A' and 'V' are ammeters and voltmeters used to record the test data required. Component 'D' is a resistive load plus resonant circuit as required for the loss of mains test as specified in BS EN 62116 set up to absorb 100% rated output of the **Inverter**. Component 'a' is an ammeter used to confirm that all the output from the **Inverter** is being absorbed by component D. Components 'B' and 'C' are set up to provide a voltage of between 10% and 40% of nominal when component 'C' carries the rated output of the **Inverter** in Amps.

Component 'C' should be short term rated to carry the load which would appear through it should it be energised at 253V for at least 1s. Component 'B' is to have an impedance of between 10 and 20 ohms per phase. If components 'B' and 'C' are short time rated than an additional switch in series with 'B' and 'C' can be inserted and arranged to be closed shortly before the main change over switch shown on the drawing and opened at the end of the test period. Components 'B' and 'C' are to have an X to R ratio of 2.5 to 1.

The test is carried out by setting up the **Inverter** and load 'D' to produce and then absorb full rated output of the **Inverter**. When zero export is shown by ammeter 'a' then the changeover switch shown is operated connecting the **Inverter** to the reduced voltage connection created by components 'B' and 'C' and disconnecting it from the normal connection. The make contact is an early make and the break contact a late break so that the **Inverter** is not disconnected from a mains connection for any significant time.

The values of voltage and current should be recorded for a period of up to 1 second when the changeover switch should be returned to the normal position. The voltage and current at relevant times shall be recorded in the type test report (**Appendix A.4 (Form C)**) including the time taken for the **Inverter** to trip. (It is expected that the **Inverter** will trip on either loss of mains or under voltage in less than one second).

A.8.4.7 Short Circuit Current Contribution for Directly Coupled technology

DNOs need to understand the contribution a makes to system fault levels in order to determine that they can continue to safely operate without exceeding design fault levels for switchgear and other circuit components.

For rotating machines BS EN 60034-4 Methods for determining synchronous machine quantities from tests should be used to establish the parameters required to be recorded in **Appendix A.4 (Form C)** under the section Fault Level Contribution.

For rotating machines and linear piston machines the test should produce a 0s – 2s plot of the short circuit current as seen at the **PGM** terminals.

*Values for parameters marked in **Appendix A.4 (Form C)** should be provided where the short circuit duration is sufficiently long to enable interpolation of the plot.

A.8.4.8 Self-Monitoring - Solid State Disconnection

Some **Inverters** include solid state switching devices to disconnect from the **DNO's Distribution Network**. In this case 9.7.9 requires the control equipment to monitor the output stage of the **Inverter** to ensure that in the event of a protection initiated trip the output voltage is either disconnected completely or reduced to a value below 50 volts **AC**. This shall be verified either by self-certification by the **Manufacturer**, or additional material shall be presented to the tester sufficient to allow an assessment to be made.

A.8.4.9 Electromagnetic Compatibility (EMC)

All equipment shall comply with the generic EMC standards: BS EN61000-6-3 Electromagnetic Compatibility, Generic Emission Standard; and BS EN61000-6-1 Electromagnetic Compatibility, Generic Immunity Standard.

Appendix B.1 Installation and Commissioning Confirmation Form

Installation and Commissioning Confirmation Form for Type B, Type C and Type D PGMs								
To	ABC electricity distribution 99 West St, Imaginary Town, ZZ99 9AA			DNO abcd@wxyz.com				
Installer or Generator Details:								
Installer								
Accreditation/Qualification								
Address								
Post Code								
Contact person								
Telephone Number								
E-mail address								
Installation Details								
Site Contact Details								
Address								
Post Code								
Site Telephone Number								
MPAN(s)								
Location within Customer's Installation								
Location of Lockable Isolation Switch								
Details of Power Generating Module(s) –								
Manufacturer / Reference	Date of Installation	Technology Type	Partial Type Test numbers and or Equipment certificate references as applicable	Power Generating Module Registered Capacity in kW				Power Factor
				3-Phase Units	Single Phase Units			
					PH1	PH2	PH3	

Information to be enclosed	
Description	Confirmation
Final copy of circuit diagram	Yes / No*
Schedule of protection settings (may be included in circuit diagram)	Yes / No*
Commissioning Checks	
Installation satisfies the requirements of BS7671 (IET Wiring Regulations).	Yes / No*
Suitable lockable points of isolation have been provided between the PGMs and the rest of the installation.	Yes / No*
Labels have been installed at all points of isolation in accordance with EREC G99.	Yes / No*
Interlocking that prevents PGMs being connected in parallel with the DNO system (without synchronising) is in place and operates correctly.	Yes / No*
The Interface Protection settings have been checked and comply with EREC G99.	Yes / No*
PGMs successfully synchronise with the DNO system without causing significant voltage disturbance.	Yes / No*
PGMs successfully run in parallel with the DNO system without tripping and without causing significant voltage disturbances.	Yes / No*

PGMs successfully disconnect without causing a significant voltage disturbance, when they are shut down.	Yes / No*
Interface Protection operates and disconnects the PGMs quickly (within 1s) when a suitably rated switch, located between the PGMs and the DNOs incoming connection, is opened.	Yes / No*
PGMs remain disconnected for at least 20s after switch is reclosed.	Yes / No*
PGMs disconnects when one phase of the supply is removed (PGMs with LV protection settings only)	
Loss of tripping and auxiliary supplies Where applicable, loss of supplies to tripping and protection relays results in either Power Generating Module lockout or an alarm to a 24hr manned control centre.	Yes / No*
*Circle as appropriate. If "No" is selected the Power Generating Facility is deemed to have failed the commissioning tests and the Power Generating Module shall not be put in service.	
Additional Comments / Observations:	
Declaration – to be completed by Generator or Generators Appointed Technical Representative.	
I declare that the PGM and the installation comply with the requirements of EREC G99, the PGMD detailed in Appendix B.2 is complete and the commissioning checks detailed in Appendix B.3 have been successfully completed.	
Name:	
Signature:	Date:
Position.	
Declaration – to be completed by DNO Witnessing Representative	
I confirm that I have witnessed the tests in this document on behalf of _____ and that the results are an accurate record of the tests	
Name:	
Signature:	Date:

Appendix B.2 Power Generating Module Document for Type B and Type C

Power Generating Module Document for Type B and Type C PGMs				
This document shall be completed by the Generator				
To	ABC electricity distribution 99 West St, Imaginary Town, ZZ99 9AA		DNO abcd@wxyz.com	
Site Details				
Site Contact Details				
Address				
Post Code				
Site Telephone Number				
Details of Power Generating Module				
Manufacturer / Reference				
Technology Type				
Registered Capacity				
Compliance confirmation				
#	Applicable Type	Description	Initial submission (at least 28 days before synchronisation)	In order to obtain Final Operational Notification from the DNO
#1	B, C	Information specified in DDRC Schedules 5a, 5b,5c and 6 has been provided to the DNO	Required	Update required
#2	B, C	Simulation studies in accordance with Appendix B.4 have been provided	Required	
#3	B, C	A detailed schedule of tests and test procedures <u>have been provided.</u>	Required	
#4		Interface with the DNO		
4.1	B	Type B PGMs Logic Interface is provided	Yes / No*	
4.2	C	For Type C PGMs the Active Power Set Point can be adjusted in accordance with instructions issued by the DNO .	Yes / No*	
#5		PGM Steady State Compliance		
		Manufacturers Information or type test reports to demonstrate compliance are referenced or attached to this submission. This shall include:		
5.1	B, C	Continuous Operation (Paragraph 12.2.1 Type B or 13.2.1 Type C)	Required	
5.2	C	Excitation System Open Circuit Step Response tests (Appendix B.5.2)	Required for Synchronous Power Generating Modules	
5.3	C	Open and Short Circuit Saturation Characteristics tests (Appendix B.5.3)	Required for Synchronous Power Generating Modules	
5.4	C	Under-excitation Limiter Performance test (Appendix B.5.4)		Required for Synchronous Power Generating Modules
5.5	C	Over-excitation Limiter Performance test (Appendix B.5.4)		Required for Synchronous Power Generating Modules
5.6	C	Power Park Module Voltage Control tests (Appendix B.6.2)		Required for Power Park

				Modules.
5.7	B and C	Reactive capability This shall include compliance with the reactive capability requirements in Section 12.5 (Type B) and Section 13.6 (Type C). For Synchronous Power Generating Modules this will be demonstrated in accordance with Appendix B.5.5 . For Power Park Modules this will be demonstrated in accordance with Appendix B.6.3 .		Required
5.8	B and C	Automatic reconnection This shall include compliance with Paragraph 10.3.4 i.e. demonstration that the reconnection sequence starts after a minimum delay of 20 seconds for restoration of voltage and frequency		Required
#6		PGM Dynamic Performance Compliance		
		Manufacturers Information or type test reports to demonstrate compliance are referenced or attached to this submission. This should include:		
6.1	B, C	Governor and Load Controller Response Performance tests (frequency response) Simulation - LSFM-O – Appendix B.4.6 , LSFM-U – Appendix B.4.7 . And Appendix B.5.6 for Synchronous tests, Appendix B.6.5 for PPM tests		Required
6.2	B, C	Active Power Output with falling frequency Appendix B.5.7 . (PPM)		Required
6.3	B, C	Fault ride through Simulation – Appendix B.4.5 PPM tests – Appendix B.6.6 Synchronous	Required	
6.4	B, C	Fast Fault Current Injection Simulation – Appendix A4.5	Required for PPM only	
#7		If applicable PGM Black Start Compliance		
7.1	C (if applicable)	Black start compliance has been obtained from the NETSO .	Yes / No*/ Not applicable	
#8		PGM Interface Protection Compliance As an alternative to demonstrating protection compliance with Section 10 using Manufacturers Information or type test reports, site tests can be undertaken at the time of commissioning the Power Generating Module .		
8.1	B, C	Over and under voltage protection HV Manufacturers Information or type test reports is referenced or attached to this submission	Yes / No*	Required in accordance with Appendix A.4 where Manufacturers Information or type test reports not previously provided
8.2	B, C	Over and Under Frequency protection Manufacturers Information or type test reports is referenced or attached to this submission – see Appendix B.3 .	Yes / No*	Required in accordance with Appendix A.4 where Manufacturers Information or type test reports

Comment [MK2]: There is an outstanding query as to the requirements for PPMs

				not previously provided
8.3	B, C	Loss of mains protection Manufacturers Information or type test reports is referenced or attached to this submission – see Appendix B.3 .	Yes / No*	Required in accordance with Appendix A.4 where Manufacturers Information or type test reports not previously provided
#9	B, C	Installation and Commissioning Form Appendix B.1 completed with signed acceptance from the DNO representative	-	Required
* Circle as appropriate.				
Date upon which the Power Generating Module will be ready to be Synchronised to the Total System				
Compliance Declaration – to be completed by Generator or Authorised Certifier. This declaration to be completed after the onsite testing and commissioning has been undertaken				
I declare that the PGM complies with the requirements of EREC G99.				
Name:				
Signature:			Date:	
Position.				

Appendix B.3 Additional Compliance and Commissioning test requirements for PGMs

Summary

Requirement	Compliance by provision of Manufacturers Information or type test reports. Reference number should be detailed and Manufacturers Information attached.	Compliance by commissioning tests Tick if true and complete relevant sections of form below
Over and under voltage protection LV –calibration test		
Over and under voltage protection LV –stability test		
Over and under voltage protection HV –calibration test		
Over and under voltage protection HV – stability test		
Over and Under Frequency protection – calibration test		
Over and Under Frequency protection - stability test		
Loss of mains protection – calibration test		
Loss of mains protection – stability test		

Over and Under Voltage Protection LV							
Where the Connection Point is at LV the Generator shall demonstrate compliance with this EREC G99 in respect of Over and Under Voltage Protection by provision of Manufacturers Information , type test reports or by undertaking the following tests on site.							
Stability Tests							
Test Description	Setting	Time Delay	Test Condition (3-Phase Value)	Test Voltage all phases ph-n	Test Duration	Confirm No Trip	Result
Inside Normal band	-----	-----	< OV Stage 1	258.2V	5.00s		Pass/Fail
Stage 1 Over Voltage	262.2V	1.0s	> OV Stage 1	269.7V	0.95s		Pass/Fail
Stage 2 Over Voltage	273.7V	0.5s	> OV Stage 2	277.7V	0.45s		Pass/Fail
Inside Normal band	-----	-----	> UV Stage 1	204.1V	5.00s		Pass/Fail
Stage 1 Under Voltage	200.1V	2.5s	< UV Stage 1	188V	2.45s		Pass/Fail
Stage 2 Under Voltage	184.0V	0.5s	< UV Stage 2	180V	0.45s		Pass/Fail
Overvoltage test - Voltage shall be stepped from 258V to the test voltage and held for the test duration and then stepped back to 258V.							
Undervoltage test – Voltage shall be stepped from 204.1V to the test voltage and held for the test duration and then stepped back to 204.1V							
Additional Comments / Observations:							

--

Over and Under Voltage Protection HV

Where the **Connection Point** is at **HV** the Generator shall demonstrate compliance with this EREC G99 in respect of Over and Under Voltage Protection by provision of **Manufacturers Information**, type test reports or by undertaking the following tests on site.

Tests referenced to 110V ph-ph VT output

Calibration and Accuracy Tests											
Phase	Setting	Time Delay	Pickup Voltage				Relay Operating Time <small>measured value plus or minus 2V</small>				
Stage 1 Over Voltage			Lower Limit	Measured Value	Upper Limit	Result	Test Value	Lower Limit	Measured Value	Upper Limit	Result
L1 - L2	121V 110V VT secondary	1.0s	119.35		122.65	Pass/Fail	Measured value plus 2V	1.0s		1.1s	Pass/Fail
L2 - L3						Pass/Fail					Pass/Fail
L3 - L1						Pass/Fail					Pass/Fail
Stage 2 Over Voltage			Lower Limit	Measured Value	Upper Limit	Result	Test Value	Lower Limit	Measured Value	Upper Limit	Result
L1 - L2	124.3V 110V VT secondary	0.5s	122.65		125.95	Pass/Fail	Measured value plus 2V	0.5s		0.6s	Pass/Fail
L2 - L3						Pass/Fail					Pass/Fail
L3 - L1						Pass/Fail					Pass/Fail
Stage 1 Under Voltage			Lower Limit	Measured Value	Upper Limit	Result	Test Value	Lower Limit	Measured Value	Upper Limit	Result
L1 - L2	95.70V 110V VT secondary	2.5s	94.05		97.35	Pass/Fail	Measured value minus 2V	2.5s		2.6s	Pass/Fail
L2 - L3						Pass/Fail					Pass/Fail
L3 - L1						Pass/Fail					Pass/Fail
Stage 2 Under Voltage			Lower Limit	Measured Value	Upper Limit	Result	Test Value	Lower Limit	Measured Value	Upper Limit	Result
L1 - L2	88.00V 110V VT secondary	0.5s	86.35		89.65	Pass/Fail	Measured value minus 2V	0.5s		0.6s	Pass/Fail
L2 - L3						Pass/Fail					Pass/Fail
L3 - L1						Pass/Fail					Pass/Fail

Over and Under Voltage Protection Tests HV

referenced to 110V ph-ph VT output

Stability Tests							
Test Description	Setting	Time Delay	Test Condition (3-Phase Value)	Test Voltage All phases ph-ph	Test Duration	Confirm No Trip	Result
Inside Normal band	-----	-----	< OV Stage 1	119V	5.00s		Pass/Fail
Stage 1 Over Voltage	121V	1.0s	> OV Stage 1	122.3V	0.95s		Pass/Fail
Stage 2 Over Voltage	124.3V	0.5s	> OV Stage 2	126.3V	0.45s		Pass/Fail
Inside Normal band	-----	-----	> UV Stage 1	97.7V	5.00s		Pass/Fail
Stage 1 Under Voltage	95.7V	2.5s	< UV Stage 1	90V	2.45s		Pass/Fail
Stage 2 Under Voltage	88V	0.5s	< UV Stage 2	86V	0.45s		Pass/Fail

Additional Comments / Observations:

--

--

Over and Under Frequency Protection										
The Generator shall demonstrate compliance with this EREC G99 in respect of Over and Under Frequency Protection by provision of Manufacturers Information , type test reports or by undertaking the following tests on site										
Calibration and Accuracy Tests										
Setting	Time Delay	Pickup Frequency				Relay Operating Time				
Over Frequency		Lower Limit	Measured Value	Upper Limit	Result	Freq step	Lower Limit	Measured Value	Upper Limit	Result
52Hz	0.5s	51.90		52.10	Pass/Fail	51.7-52.3Hz	0.50s		0.60s	Pass/Fail
Stage 1 Under Frequency		Lower Limit	Measured Value	Upper Limit	Result	Freq step	Lower Limit	Measured Value	Upper Limit	Result
47.5Hz	20s	47.40		47.60	Pass/Fail	47.8-47.2Hz	20.0s		20.2s	Pass/Fail
Stage 2 Under Frequency		Lower Limit	Measured Value	Upper Limit	Result	Freq step	Lower Limit	Measured Value	Upper Limit	Result
47Hz	0.5s	46.90		47.1	Pass/Fail	47.3-46.7Hz	0.50s		0.60s	Pass/Fail
Stability Tests										
Test Description	Setting	Time Delay	Test Condition	Test Frequency	Test Duration	Confirm No Trip	Result			
Inside Normal band	-----	-----	< OF Stage 1	51.3Hz	120s		Pass/Fail			
Over Frequency	52Hz	0.5s	> OF Stage 2	52.2Hz	0.45s		Pass/Fail			
Inside Normal band	-----	-----	> UF Stage 1	47.7Hz	30s		Pass/Fail			
Stage 1 Under Frequency	47.5Hz	20s	< UF Stage 1	47.3Hz	19.5s		Pass/Fail			
Stage 2 Under Frequency	47Hz	0.5s	< UF Stage 2	46.8Hz	0.45s		Pass/Fail			
Overfrequency test - Frequency shall be stepped from 51.3Hz to the test frequency and held for the test duration and then stepped back to 51.3Hz.										
Underfrequency test - Frequency shall be stepped from 47.1Hz to the test frequency and held for the test duration and then stepped back to 47.1Hz										
Additional Comments / Observations:										

Details of Loss of Mains Protection				
Manufacturer	Manufacturer's type	Date of Installation	Settings	Other information

Loss-of-Mains (LOM) Protection Tests – RoCoF for Type A, Type B and Type C Power Generating Facilities		
The Generator shall demonstrate compliance with this EREC G99 in respect of LOM Protection by either providing the DNO with appropriate Manufacturers Information , type test reports or by undertaking the following tests on site		
Calibration and Accuracy Tests		
Ramp in range 49.0-51.0Hz	Pickup (+ / -0.025Hzs⁻¹)	Relay Operating Time RoCoF= $\pm 0.05 / 0.10\text{Hzs}^{-1}$ above setting

Setting = 0.5 / 1.0 Hz ⁻¹	Lower Limit	Measured Value	Upper Limit	Result	Test Condition	Lower Limit	Measured Value	Upper Limit	Result
Increasing Frequency	0.475 0.975		0.525 1.025	Pass/Fail	0.55 Hzs ⁻¹ 1.10 Hzs ⁻¹	>0.5s		<1.0s	Pass/Fail
Reducing Frequency	0.475 0.975		0.525 1.025	Pass/Fail	0.55 Hzs ⁻¹ 1.1 Hzs ⁻¹	>0.5s		<1.0s	Pass/Fail

Stability Tests

Ramp in range 49.0-51.0Hz	Test Condition	Test frequency ramp	Test Duration	Confirm No Trip	Result
Inside Normal band	< RoCoF (increasing f)	0.45Hzs ⁻¹ 0.95 Hzs ⁻¹	4.4s		Pass/Fail
Inside Normal band	< RoCoF (reducing f)		2.1s		Pass/Fail

Additional Comments / Observations:

--	--

LoM Protection - Stability test

Start Frequency	Change	End Frequency	Confirm no trip
49.5Hz	+50 degrees		
50.5Hz	- 50 degrees		

Insert here any additional tests which have been carried out

--	--

Appendix B.4 Simulation Studies for Type B, Type C and Type D Power Generating Modules

- B.4.1.1 This Appendix sets out the simulation studies required to be submitted to the **DNO** to demonstrate compliance with EREC G99 unless otherwise agreed with the **DNO**. This Appendix should be read in conjunction with Section 21.4 with regard to the submission of the reports to the **DNO**. The studies specified in this Appendix will normally be sufficient to demonstrate compliance. However, the **DNO** may agree an alternative set of studies proposed by the **Generator** provided the **DNO** deems the alternative set of studies sufficient to demonstrate compliance with the EREC G99 and the **Connection Agreement**.
- B.4.1.2 The **Generator** shall submit simulation studies in the form of a report to demonstrate compliance. In all cases the simulation studies must utilise models applicable to the **Synchronous Power Generating Module** or **Power Park Module** with proposed or actual parameter settings. Reports should be submitted in English with all diagrams and graphs plotted clearly with legible axes and scaling provided to ensure any variations in plotted values is clear.
- B.4.1.3 The **DNO** may permit relaxation from the requirement in paragraph B.4.2 to paragraph B.4.8 where **Manufacturers Information** for the **Power Generating Module** has been provided which details the characteristics from appropriate simulations on a representative installation with the same equipment and settings and the performance of the **Power Generating Module** can, in the **DNOs** opinion, reasonably represent that of the installed **Power Generating Module**.
- B.4.1.4 For **Type B, Type C** and **Type D Power Generating Modules** the relevant **Manufacturers Information** must be supplied in the **Power Generating Module Document** or DDRRC as applicable.
- B.4.2 Power System Stabiliser Tuning
- B.4.2.1 In the case of a **Synchronous Power Generating Module** with a **Power System Stabiliser** the **Power System Stabiliser** tuning simulation study report required by the **Grid Code** C.1.2.5.6 shall be submitted in accordance with **Grid Code** EPC.A.3.2.1.
- B.4.2.2 In the case of **Power Park Modules** with a **Power System Stabiliser** at the **Connection Point** the **Power System Stabiliser** tuning simulation study report required by the **Grid Code** C.2.2.4.1 shall contain be submitted in accordance with **Grid Code** ECP.A.3.2.2.
- B.4.3 Reactive Capability across the Voltage Range
- B.4.3.1 The **Generator** shall supply simulation studies to demonstrate the capability to meet Section 12.5 or 13.6 as applicable by submission of a report containing:
- (i) a load flow simulation study result to demonstrate the maximum lagging **Reactive Power** capability of the **Synchronous Power Generating Module** or **Power Park Module** at **Registered Capacity** when the **Connection Point** voltage is at 105% of nominal.
 - (ii) a load flow simulation study result to demonstrate the maximum leading **Reactive Power** capability of the **Synchronous Power Generating Module** or **Power Park Module** at **Registered Capacity** when the **Connection Point** voltage is at 95% of nominal.
 - (iii) a load flow simulation study result to demonstrate the maximum lagging **Reactive Power** capability of the **Synchronous Power Generating Module** or **Power Park Module** at the **Minimum Generation** when the **Connection Point** voltage is at 105% of nominal.
 - (iv) a load flow simulation study result to demonstrate the maximum leading **Reactive Power** capability of the **Synchronous Power Generating Module** or **Power Park Module** at the **Minimum Generation** when the **Connection Point** voltage is at 95% of nominal.
- B.4.3.2 In the case of a **Synchronous Power Generating Module** the terminal voltage in the simulation should be the nominal voltage for the machine.
- B.4.3.3 In the case of a **Power Park Module** where the load flow simulation studies show that the individual **Generating Units** deviate from nominal voltage to meet the **Reactive Power** requirements then evidence must be provided from factory (e.g. **Manufactures Information**) or site testing that the **Generating**

Unit is capable of operating continuously at the operating points determined in the load flow simulation studies.

B.4.4 Voltage Control and Reactive Power Stability

- B.4.4.1** This section applies to **Type C** and **Type D Power Park Modules** to demonstrate the voltage control capability and **Type B Power Park Modules** to demonstrate the voltage control capability if specified by the **DNO**.
- B.4.4.2** In the case of a **Power Generating Facility** containing **Power Park Modules** the **Generator** shall provide a report to demonstrate the dynamic capability and control stability of the **Power Park Module**. The report shall contain:
- (i) a dynamic time series simulation study result of a sufficiently large negative step in system voltage to cause a change in **Reactive Power** from zero to the maximum lagging value at **Registered Capacity**.
 - (ii) a dynamic time series simulation study result of a sufficiently large positive step in system voltage to cause a change in **Reactive Power** from zero to the maximum leading value at **Registered Capacity**.
 - (iii) a dynamic time series simulation study result to demonstrate control stability at the lagging **Reactive Power** limit by application of a -2% voltage step while operating within 5% of the lagging **Reactive Power** limit.
 - (iv) a dynamic time series simulation study result to demonstrate control stability at the leading **Reactive Power** limit by application of a +2% voltage step while operating within 5% of the leading **Reactive Power** limit.
- B.4.4.3** All the above studies should be completed with a nominal network voltage for zero **Reactive Power** transfer at the **Connection Point** unless stated otherwise and the fault level at the **Connection Point** at minimum as agreed with the **DNO**.
- B.4.4.4** The **DNO** may permit relaxation from the requirements of **B.4.4.2(i)** and **(ii)** for voltage control if the **Power Park Modules** are comprised of **Power Park Units** in respect of which the **Generator** has in its submissions to the **DNO** referenced an appropriate **Manufacturers' Information** which is acceptable to the **DNO** for voltage control.
- B.4.4.5** In addition the **DNO** may permit a further relaxation from the requirements of **B.4.4.2(iii)** and **(iv)** if the **Generator** has in its submissions to the **DNO** referenced appropriate **Manufacturers' Information** for a **Power Park Module** mathematical model for voltage control acceptable to the **DNO**.

B.4.5 Fault Ride Through and Fast Fault Current Injection

- B.4.5.1** This section applies to **Type B, Type C and Type D Power Generating Modules** to demonstrate the modules fault ride through and **Fast Fault Current** injection capability.
- B.4.5.2** The **Generator** shall supply time series simulation study results to demonstrate the capability of **Synchronous Power Generating Modules** and **Power Park Modules** to meet paragraphs **11.3** and **13.4** as applicable by submission of a report containing:
- (i) a time series simulation study of a 140ms three phase short circuit fault with a retained voltage as detailed in **table B.4.5.1** applied at the **Connection Point** of the **Power Generating Module**.
 - (ii) a time series simulation study of 140ms unbalanced short circuit faults with a retained voltage as detailed in **table B.4.5.1** on the faulted phase(s) applied at the **Connection Point** of the **Power Generating Module**. The unbalanced faults to be simulated are:
 1. a phase to phase fault
 2. a two phase to earth fault
 3. a single phase to earth fault.

Power Generating Module	Retained Voltage
Synchronous Power Generating Module	
Type B	30%
Type C or Type D with Grid connection point	10%

voltage <110kV	
Type D with connection point voltage >110kV	0%
Power Park Module	
Type B or Type C or Type D with connection point voltage < 110kV	10%
Type D with connection point voltage >110kV	0%
HVDC Equipment	10%

Table B.4.5.1

For a Synchronous Power Generating Module the simulation study should be completed with the Synchronous Power Generating Module operating at full Active Power and maximum leading **Reactive Power** and the fault level at the **Connection Point** at minimum or as otherwise agreed with the **DNO**.

(iii) time series simulation studies of balanced Supergrid voltage dips applied on the nearest point of the **National Electricity Transmission System** operating at Supergrid voltage to the **Synchronous Power Generating Module**. The simulation studies should include:

1. 50% retained voltage lasting 0.45 seconds
2. 70% retained voltage lasting 0.81 seconds
3. 80% retained voltage lasting 1.00 seconds
4. 85% retained voltage lasting 180 seconds.

For a **Type C** or **Type D Synchronous Power Generating Module**, the simulation study should be completed with the **Synchronous Power Generating Module** operating at full **Active Power** and zero **Reactive Power** output. The minimum **DNOs** system impedance to the Supergrid HV connection point shall be used which may be calculated from the maximum fault level at the **Connection Point** or taken from standard values for this purpose provided by the **DNO**.

(iv) time series simulation studies of balanced Supergrid voltage dips applied on the nearest point of the **National Electricity Transmission System** operating at Supergrid voltage to the **Power Park Module**. The simulation studies should include:

1. 30% retained voltage lasting 0.384 seconds
2. 50% retained voltage lasting 0.71 seconds
3. 80% retained voltage lasting 2.5 seconds
4. 85% retained voltage lasting 180 seconds.

For Power Park Modules the simulation study should be completed with the Power Park Module operating at full **Active Power** and zero **Reactive Power** output. The minimum **DNOs** system impedance to the Supergrid HV connection point shall be used which may be calculated from the maximum fault level at the **Connection Point**.

B.4.5.3

In the case of **Power Park Modules** comprised of **Generating Units** in respect of which the **Generator's** reference to **Manufacturers Information** has been accepted by the **DNO** for **Fault Ride Through**, B.4.5.2 will not apply provided:

(i) the **Generator** demonstrates by load flow simulation study result that the faults and voltage dips at either side of the **Generating Unit** transformer corresponding to the required faults and voltage dips in B.4.5.2 applied at the nearest point of the **National Electricity Transmission System** operating at Supergrid voltage are less than those included in the **Manufacturers Information**,

or;

(ii) the same or greater percentage faults and voltage dips in B.4.5.2 have been applied at either side of the **Generating Unit** transformer in the **Manufacturers Information**.

B.4.6 Limited Frequency Sensitive Mode – Over Frequency (LFSM-O)

B.4.6.1 This section applies to **Type B, Type C and Type D Power Generating Modules** to demonstrate the capability to modulate **Active Power** at high frequency.

B.4.6.2 The simulation study should comprise of a **Power Generating Module** connected to the **Total System** with a local load shown as “X” in **figure B.4.1**. The load “X” is in addition to any auxiliary load of the **Power Generating Facility** connected directly to the **Power Generating Module** and represents a small portion of the system to which the **Power Generating Module** is attached. The value of “X” should be the minimum for which the **Power Generating Module** can control the power island frequency to less than 52Hz. Where transient excursions above 52Hz occur the **Generator** should ensure that the duration above 52Hz is less than any high frequency protection system applied to the **Power Generating Module**.

B.4.6.3 For **Power Park Modules** consisting of units connected wholly by power electronic devices an additional **Synchronous Power Generating Module (G2)** may be connected as indicated in **Figure B.4.2**. This additional **Synchronous Power Generating Module** should have an inertia constant of 3.5MWs/MVA, be initially operating at rated power output and unity power factor. The mechanical power of the **Synchronous Power Generating Module (G2)** should remain constant throughout the simulation.

B.4.6.4 At the start of the simulation study the **Power Generating Module** will be operating maximum **Active Power** output. The **Power Generating Module** will then be islanded from the **Total System** but still supplying load “X” by the opening of a breaker, which is not the **Power Generating Module** or connection circuit breaker (the governor should therefore, not receive any signals that the breaker has opened other than the reduction in load and subsequent increase in speed). A schematic arrangement of the simulation study is illustrated by **Figure B.4.1**.

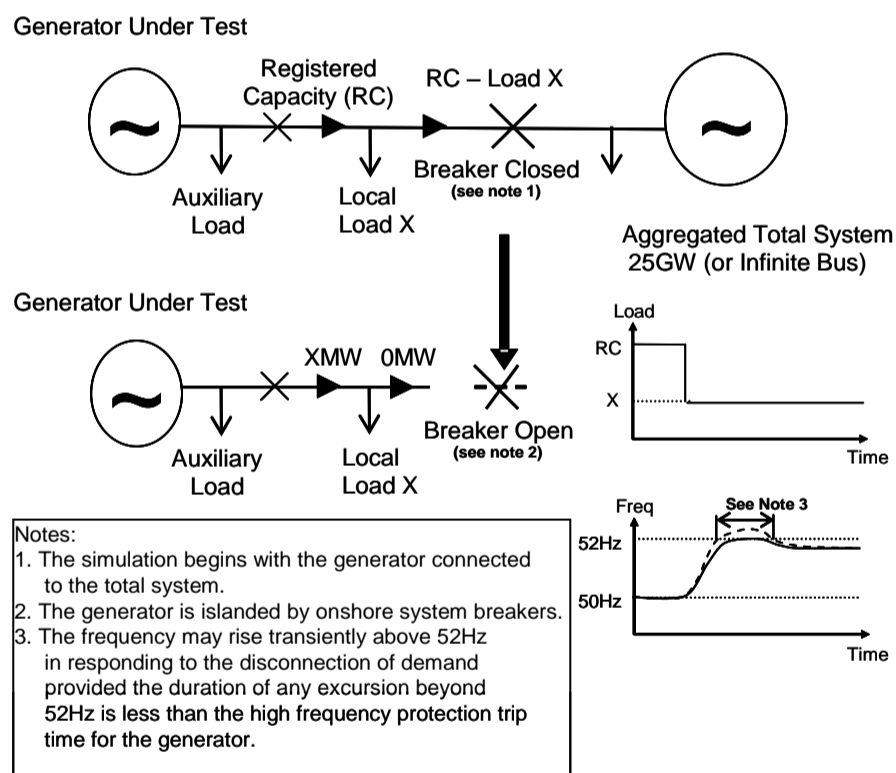

Figure B.4.1 – Diagram of Load Rejection Study

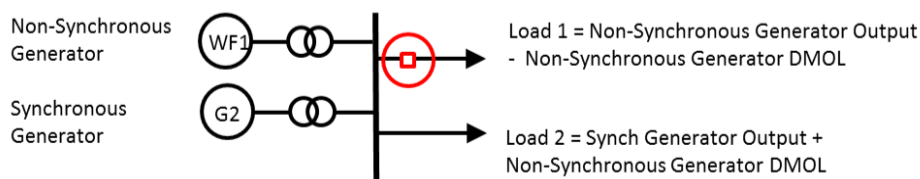

Figure B.4.2 – Addition of Generator G2 if applicable

B.4.6.5 Simulation studies shall be performed for **Type B, Type C and Type D** in **Limited Frequency Sensitive Mode (LFSM)** and **Frequency Sensitive Mode (FSM)** for **Type C and Type D**. The simulation study results should indicate **Active Power** and frequency.

B.4.6.7 To allow validation of the model used to simulate load rejection in accordance with paragraph 12.2.5 and 13.2.4 as applicable a further simulation study is required to represent the largest positive frequency

injection step or fast ramp (BC1 and BC3 of [Figure B.5.1](#) and [Figure B.6.3](#)) that will be applied as a test as described in [B.5.8](#) and [B.6.6](#).

B.4.7 Limited Frequency Sensitive Mode – Under Frequency (LFSM-U)

B.4.7.1 This section applies to **Type C** and **Type D Synchronous Power Generating Modules** and **Type C** and **Type D Power Park Modules** to demonstrate the modules capability to modulate **Active Power** at low frequency.

B.4.7.2 To demonstrate the **LFSM-U** low frequency control when operating in **Limited Frequency Sensitive Mode** the **Generator** shall submit a simulation study representing the response of the **Power Generating Module** operating at 80% of **Registered Capacity**. The simulation study event shall be equivalent to:

- (i) a sufficiently large reduction in the measured system frequency ramped over 10 seconds to cause an increase in **Active Power** output to the **Registered Capacity** followed by
- (ii) 60 seconds of steady state with the measured system frequency depressed to the same level as in [B.4.7.2 \(i\)](#) as illustrated in [Figure B.4.3](#) below.
- (iii) then increase of the measured system frequency ramped over 10 seconds to cause a reduction in **Active Power** output back to the original **Active Power** level followed by at least 60 seconds of steady output.

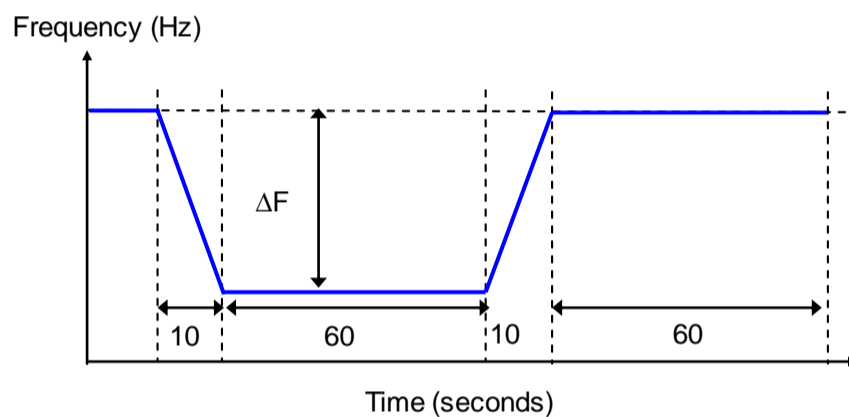

Figure B.4.3

B.4.8 Voltage and Frequency Controller Model Verification and Validation

B.4.8.1 For **Type C** and **Type D Synchronous Power Generating Modules** and **Power Park Modules** the **Generator** shall provide simulation studies to verify that the proposed controller models supplied to the **DNO** under the DDRC are fit for purpose. These simulation study results shall be provided in the timescales stated in the DDRC.

B.4.8.2 To demonstrate the frequency control or governor/load controller/plant model the **Generator** shall submit a simulation study representing the response of the **Synchronous Power Generating Module** or **Power Park Module** operating at 80% of **Registered Capacity**. The simulation study event shall be equivalent to:

- (i) a ramped reduction in the measured system frequency of 0.5Hz in 10 seconds followed by
- (ii) 20 seconds of steady state with the measured system frequency depressed by 0.5Hz followed by
- (iii) a ramped increase in measured system frequency of 0.3Hz over 30 seconds followed by
- (iv) 60 seconds of steady state with the measured system frequency depressed by 0.2Hz as illustrated in [Figure B.4.4](#) below.

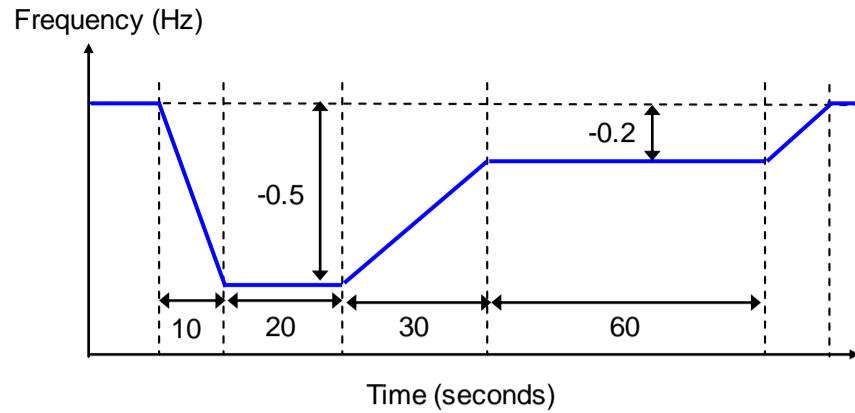

Figure B.4.4

The simulation study shall show **Active Power** output (MW) and the equivalent of frequency injected.

B.4.8.3 To demonstrate the Excitation System model the **Generator** shall submit simulation studies representing the response of the **Synchronous Power Generating Module** as follows:

- (i) operating open circuit at rated terminal voltage and subjected to a 10% step increase in terminal voltage reference from 90% to 100%.
- (ii) operating at **Registered Capacity**, nominal terminal voltage and unity power factor subjected to a 2% step increase in the voltage reference. Where a **Power System Stabiliser** is included within the Excitation System this shall be in service.

The simulation study shall show the **Synchronous Power Generating Module** terminal voltage, field voltage, **Active Power**, **Reactive Power** and **Power System Stabiliser** output signal as appropriate.

B.4.8.4 To demonstrate the Voltage Controller model the shall submit a simulation study representing the response of the Power Park Module operating at **Registered Capacity** and unity power factor at the connection point to a 2% step increase in the voltage reference. The simulation study shall show the terminal voltage, **Active Power**, **Reactive Power** and **Power System Stabiliser** output signal as appropriate.

B.4.8.5 To validate that the excitation and voltage control models submitted under the DDRC are a reasonable **representation of the dynamic behaviour of the Synchronous Power Generating Module** or **Power Park Module** as built, the **Generator** shall repeat the simulation studies outlined above but using the operating conditions of the equivalent tests. The simulation study results shall be displayed overlaid on the actual test results.

B.4.8.6 For **Type C** and **Type D Synchronous Power Generating Modules** to validate that the governor/load controller/plant or frequency control models submitted under the DDRC is a reasonable representation of the dynamic behaviour of the **Synchronous Power Generating Module** as built, the **Generator** shall repeat the simulation studies outlined above but using the operating conditions of the equivalent tests. The simulation study results shall be displayed overlaid on the actual test results.

Appendix B.5 Compliance Testing of Synchronous Power Generating Modules

B.5.1 Scope

B.5.1.1 This Appendix sets out the tests contained therein to demonstrate compliance with the relevant clauses of the EREC G99.

B.5.1.2 The tests specified in this Appendix will normally be sufficient to demonstrate compliance however the **DNO** may:

(i) agree an alternative set of tests provided the **DNO** deems the alternative set of tests sufficient to demonstrate compliance with this EREC G99 and the **Connection Agreement**; and/or

(ii) require additional or alternative tests if information supplied to the **DNO** during the compliance process suggests that the tests in this Appendix will not fully demonstrate compliance with the relevant section of the EREC G99 or the **Connection Agreement**.

(iii) Agree a reduced set of tests for subsequent **Synchronous Power Generating Module** following successful completion of the first **Synchronous Power Generating Module** tests in the case of a **Power Generating Facility** comprised of two or more **Synchronous Power Generating Modules** which the **DNO** reasonably considers to be identical.

If:

(a) the tests performed pursuant to **B.5.1.2(iii)** in respect of subsequent **Synchronous Power Generating Modules** do not replicate the full tests for the first **Synchronous Power Generating Module**, or

(b) any of the tests performed pursuant to **B.5.1.2(iii)** do not fully demonstrate compliance with the relevant aspects of EREC G99, the **Connection Agreement**, or an any other contractual agreement with the **DNO** if applicable;

then notwithstanding the provisions above, the full testing requirements set out in this Appendix will be applied.

B.5.1.3 The **Generator** is responsible for carrying out the tests set out in and in accordance with this Appendix and the **Generator** retains the responsibility for the safety of personnel and plant during the test. The **DNO** will witness all of the tests outlined or agreed in relation to this Appendix unless the **DNO** decides and notifies the **Generator** otherwise. Reactive Capability tests may be witnessed by the **DNO** remotely from the **DNO** control centre. For all on site **DNO** witnessed tests the **Generator** should ensure suitable representatives from the **Generator** and manufacturer (if appropriate) are available on site for the entire testing period.

B.5.1.8 Full **Synchronous Power Generating Module** testing is to be completed as defined in **B.5.2** through to **B.5.9**.

B.5.1.9 The **DNO** may permit relaxation from the requirement **B.5.2 to B.5.9** where **Manufacturers Information** for the **Synchronous Power Generating Module** has been provided which details the characteristics from tests on a representative machine with the same equipment and settings and the performance of the **Synchronous Power Generating Module** can, in the **DNOs** opinion, reasonably represent that of the installed **Synchronous Power Generating Module** at that site. For **Type C** and **Type D Power Generating Modules** the relevant **Manufacturers Information** must be supplied in the **Power Generating Module Document** or the **DDRC** as applicable.

B.5.2 Excitation System Open Circuit Step Response Tests

B.5.2.1 The open circuit step response of the **Excitation System** will be tested by applying a voltage step change from 90% to 100% of the nominal **Synchronous Power Generating Module** terminal voltage, with the **Synchronous Power Generating Module** on open circuit and at rated speed.

B.5.2.2 The test shall be carried out prior to synchronisation. This is not witnessed by the **DNO** unless specifically requested by the **DNO**. Where the **DNO** is not witnessing the tests, the Generator shall supply the recordings of the following signals to the **DNO** in an electronic spreadsheet format:

V_t - Synchronous **Generating Unit** terminal voltage

E_{fd} - Synchronous **Generating Unit** field voltage or main exciter field voltage

I_{fd} - Synchronous **Generating Unit** field current (where possible)

Step injection signal

B.5.2.3 Results shall be legible, identifiable by labelling, and shall have appropriate scaling.

B.5.3 Open & Short Circuit Saturation Characteristics

B.5.3.1 The test shall normally be carried out prior to synchronisation. **Manufacturers Information** may be used where appropriate may be used if agreed by the **DNO**.

B.5.3.2 This is not witnessed by the **DNO**. Graphical and tabular representations of the results in an electronic spreadsheet format showing per unit open circuit terminal voltage and short circuit current versus per unit field current shall be submitted to the **DNO**.

B.5.3.3 Results shall be legible, identifiable by labelling, and shall have appropriate scaling.

B.5.4 Excitation System On-Load Tests

B.5.4.1 The time domain performance of the **Excitation System** shall be tested by application of voltage step changes corresponding to 1% and 2% of the nominal terminal voltage.

B.5.4.2 Where a **Power System Stabiliser** is present the tests should be carried out in accordance with the Grid Code ECP.A.5.4.2.

B.5.4.3 Under-excitation Limiter Performance Test

B.5.4.3.1 Initially the performance of the **Under-excitation Limiter** should be checked by moving the limit line close to the operating point of the **Generating Unit** when operating close to unity power factor. The operating point of the **Generating Unit** is then stepped into the limit by applying a 2% decrease in **Automatic Voltage Regulator** Setpoint voltage.

B.5.4.3.2 The final performance of the **Under-excitation Limiter** shall be demonstrated by testing its response to a step change corresponding to a 2% decrease in **Automatic Voltage Regulator** Setpoint voltage when the **Generating Unit** is operating just off the limit line, at the designed setting as indicated on the **Performance Chart [P-Q Capability Diagram]** submitted to the **DNO** under DDRC Schedule 5.

B.5.4.3.3 Where possible the **Under-excitation Limiter** should also be tested by operating the tap- changer when the **Generating Unit** is operating just off the limit line, as set up.

B.5.4.3.4 The **Under-excitation Limiter** will normally be tested at low **Active Power** output (minimum generation) and at maximum **Active Power** output (**Registered Capacity**).

B.5.4.3.5 The following typical procedure is provided to assist **Generators** in drawing up their own site specific procedures for the **DNO** witnessed **Under-excitation Limiter** Tests.

Test	Injection	Notes
	Generating Unit running at Registered Capacity and unity power factor. Under-excitation limit temporarily moved close to the operating point of the Generating Unit .	
1	<ul style="list-style-type: none"> • PSS on (if applicable). • Inject -2% voltage step into AVR voltage Setpoint and hold at least for 10 seconds until stabilised • Remove step returning AVR Voltage Setpoint to nominal and hold for at least 10 seconds 	
	Under-excitation limit moved to normal position. Generating Unit running at Registered Capacity and at leading Reactive Power close to Under-excitation limit.	
2	<ul style="list-style-type: none"> • PSS on (if applicable). • Inject -2% voltage step into AVR voltage Setpoint and hold at least for 10 seconds until stabilised • Remove step returning AVR Voltage Setpoint to nominal and hold for at least 10 seconds 	

B.5.4.4 Over-excitation Limiter Performance Test

B.5.4.1 The performance of the **Over-excitation Limiter**, where it exists, shall be demonstrated by testing its response to a step increase in the Automatic Voltage Regulator Setpoint voltage that results in operation of **the Over-excitation Limiter**. Prior to application of the step the **Generating Unit** shall be generating **Registered Capacity** and operating within its continuous **Reactive Power** capability. The size of the step will be determined by the minimum value necessary to operate the **Over-excitation Limiter** and will be agreed by the **DNO** and the **Generator**. The resulting operation beyond the **Over-excitation Limit** shall be controlled by the **Over-excitation Limiter** without the operation of any protection that could trip the **Power Generating Module**. The step shall be removed immediately on completion of the test.

B.5.4.4.2 If the **Over-excitation Limiter** has multiple levels to account for heating effects, an explanation of this functionality will be necessary and if appropriate, a description of how this can be tested.

B.5.4.4.3 The following typical procedure is provided to assist **Generators** in drawing up their own site specific procedures for the **DNO** witnessed **Under-excitation Limiter** Tests.

Test	Injection	Notes
	Generating Unit running at Registered Capacity and maximum lagging Reactive Power .	
	Over-excitation Limit temporarily set close to this operating point. PSS on (if applicable).	
1	<ul style="list-style-type: none"> • Inject positive voltage step into AVR voltage setpoint and hold • Wait till Over-excitation Limiter operates after sufficient time delay to bring back the excitation back to the limit. • Remove step returning AVR voltage setpoint to nominal. 	
	Over-excitation Limit restored to its normal operating value. PSS on (if applicable).	

B.5.5 **Reactive Capability**

B.5.5.1 The **Reactive Power** capability on each **Synchronous Power Generating Module** will normally be demonstrated by:

- (a) operation of the **Synchronous Power Generating Module** at maximum lagging **Reactive Power** and **Registered Capacity** for 1 hour
- (b) operation of the **Synchronous Power Generating Module** at maximum leading **Reactive Power** and **Registered Capacity** for 1 hour.
- (c) operation of the **Synchronous Power Generating Module** at maximum lagging **Reactive Power** and **Minimum Generation** for 1 hour
- (d) operation of the **Synchronous Power Generating Module** at maximum leading **Reactive Power** and **Minimum Generation** for 1 hour.
- (e) operation of the **Synchronous Power Generating Module** at maximum lagging **Reactive Power** and a power output between **Registered Capacity** and **Minimum Generation**.
- (f) operation of the **Synchronous Power Generating Module** at maximum leading **Reactive Power** and a power output between **Registered Capacity** and **Minimum Generation**.

B.5.5.2 Where **Distribution Network** considerations restrict the **Synchronous Power Generating Module Reactive Power** output then the maximum leading and lagging capability will be demonstrated without breaching the **DNO** limits.

B.5.5.3 The test procedure, time and date will be agreed with the **DNO** and will be to the instruction of the **DNO** control centre and shall be monitored and recorded

at both the **DNO** control centre and by the **Generator**.

B.5.5.4 Where the **Generator** is recording the voltage and **Reactive Power** at the **Synchronous Power Generating Module** terminals the voltage, **Active Power** and **Reactive Power** at the **Connection Point** shall be included. The results shall be supplied in an electronic spreadsheet format.

B.5.6 Governor and Load Controller Response Performance

B.5.6.1 The governor and load controller response performance will be tested by injecting simulated frequency deviations into the governor and load controller systems. Such simulated frequency deviation signals must be injected simultaneously at both speed governor and load controller setpoints. For **CCGT modules**, simultaneous injection into all gas turbines, steam turbine governors and module controllers is required.

B.5.6.2 Where a **CCGT module** or **Synchronous Power Generating Module** is capable of operating on alternative fuels, tests will be required to demonstrate performance when operating on each fuel. The **DNO** may agree a reduction from the tests listed in **B.5.8.5** for demonstrating performance on the alternative fuel. This includes the case where a main fuel is supplemented by bio-fuel.

B.5.6.3 Full Frequency Response Testing Schedule Witnessed by the **DNO**

The tests are to be conducted at a number of different Module Load Points (MLP) based on fractions of the maximum export level (MEL). The MEL is a series of MW figures and associated times, making up a profile of the maximum level at which the **Power Generating Module** may be exporting at the **Connection Point**.

The load points are conducted as shown below unless agreed otherwise by the **DNO**.

Module Load Point 6 (MEL)	100% MEL
Module Load Point 5	95% MEL
Module Load Point 4 (Mid-point of Operating Range)	80% MEL
Module Load Point 3	70% MEL
Module Load Point 2 (Minimum Generation)	MG
Module Load Point 1 (Minimum Generation)	MRL

B.5.6.4 The tests are divided into the following two types;

- (i) Frequency response tests in Limited Frequency Sensitive Mode (LFSM) to demonstrate **LFSM-O** capability for **Type B**, **Type C** and **Type D** and **LFSM-U** capability for **Type C** and **Type D** as shown by **Figure B.5.1**.
- (ii) System islanding and step response tests if required by the **DNO**.

B.5.6.5 There should be sufficient time allowed between tests for control systems to reach steady state. Where the diagram states 'HOLD' the current injection should be maintained until the **Active Power** (MW) output of the **Synchronous Power Generating Module** or **CCGT Module** has stabilised. The **DNO** may require repeat tests should the tests give unexpected results.

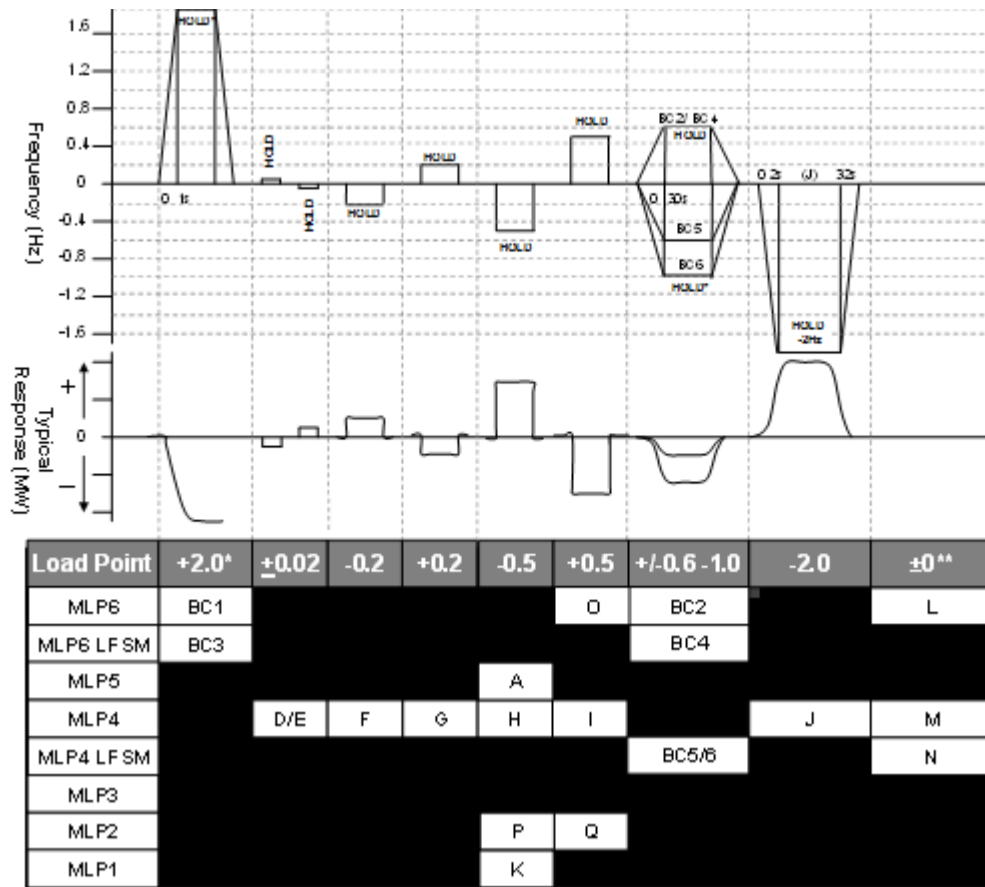

Figure B.5.1: Step response tests

* This will generally be +2.0Hz unless an injection of this size causes a reduction in plant output that takes the operating point below **Minimum Generation** in which case an appropriate injection should be calculated in accordance with the following:

For example 0.9Hz is needed to take an initial output 65% to a final output of 20%. If the initial output was not 65% and the **Minimum Generation** is not 20% then the injected step should be adjusted accordingly as shown in the example given below

Initial Output	65%
Minimum Generation	20%
Frequency Controller Droop	4%
Frequency to be injected = $(0.65-0.20) \times 0.04 \times 50$	= 0.9Hz

** Tests L and M in [Figure B.5.1](#) shall be conducted if in this range of tests the system frequency feedback signal is replaced by the injection signal rather than the injection signal being added to the system frequency signal. The tests will consist of monitoring the **Synchronous Power Generating Module and CCGT Module** in **Frequency Sensitive Mode** during normal system frequency variations without applying any injection. Test N in [Figure B.5.1](#) shall be conducted in all cases. Both tests should be conducted for a period of at least 10 minutes.

B.5.6.6 The target frequency adjustment facility should be demonstrated from the normal control point within the range of 49.9Hz to 50.1Hz by step changes to the target frequency setpoint.

B.5.7 Compliance with Output power with falling frequency Functionality Test

B.5.7.1 Where the plant design includes active control function or functions to deliver compliance with the output power with falling frequency technical requirements in the EREC G99, the **Generator** will propose and agree a test procedure with the **DNO**, which will demonstrate how the **Synchronous Power Generating Module Active Power** output responds to changes in system frequency and ambient conditions (eg by frequency and temperature injection methods).

B.5.7.2 The Generator shall inform the **DNO** if any load limiter control is additionally employed.

B.5.7.3 With Setpoint to the signals specified in [Appendix B.5](#), the **DNO** will agree with the **Generator** which additional control system parameters shall be monitored to demonstrate compliance. The results shall be supplied to the **DNO** in an electronic spreadsheet format.

Appendix B.6 Compliance Testing of Power Park Modules

B.6.1 Scope

B.6.1.1 This Appendix outlines the general testing requirements for **Power Park** to demonstrate compliance with the relevant clauses of the EREC G99.

B.6.1.2 The tests specified in this Appendix will normally be sufficient to demonstrate compliance however the **DNO** may:

- i) agree an alternative set of tests provided the **DNO** deems the alternative set of tests sufficient to demonstrate compliance with t this EREC G99 and the **Connection Agreement**; and/or
- ii) require additional or alternative tests if information supplied to the **DNO** during the compliance process suggests that the tests in this Appendix will not fully demonstrate compliance with the relevant section of this EREC G99 and the **Connection Agreement**; and/or
- iii) require additional tests if a **Power System Stabiliser** is fitted; and/or
- iv) agree a reduced set of tests if a relevant **Manufacturer's Data & Performance Report** has been submitted to and deemed to be appropriate by the **DNO**; and/or
- v) agree a reduced set of tests for subsequent **Power Park Modules** following successful completion of the first **Power Park Module** tests in the case of a **Power Station** comprised of two or more **Power Park Modules** which the **DNO** reasonably considers to be identical.

If:

- (a) the tests performed pursuant to **B.6.1.1(iv)** do not replicate the results contained in the **Manufacturer's Data & Performance Report** or
- (b) the tests performed pursuant to **B.6.1.1(v)** in respect of subsequent **Power Park Modules** or **OTSDUA** do not replicate the full tests for the first **Power Park Module** or **OTSDUA**, or
- (c) any of the tests performed pursuant to **B.6.1.1(iv)** or **B.6.1.1(v)** do not fully demonstrate compliance with the relevant aspects of the this EREC G99 and the **Connection Agreement**,

then notwithstanding the provisions above, the full testing requirements set out in this Appendix will be applied.

B.6.1.2 The **Generator** is responsible for carrying out the tests set out in and in accordance with this Appendix and the **Generator** retains the responsibility for the safety of personnel and plant during the test. The **DNO** will witness all of the tests outlined or agreed in relation to this Appendix unless the **DNO** decides and notifies the **Generator** otherwise. Reactive Capability tests may be witnessed by the **DNO** remotely from the **DNO** control centre. For all on site **DNO** witnessed tests the **Generator** must ensure suitable representatives from the **Generator** and / or **Power Park Module** manufacturer (if appropriate) are available on site for the entire testing period. In all cases and in addition to any recording of signals conducted by the **DNO** the **Generator** shall record all relevant test signals.

B.6.1.3 The **Generator** shall inform the **DNO** of the following information prior to the commencement of the tests and any changes to the following, if any values change during the tests:

- i) All relevant transformer tap numbers; and
- ii) Number of **Generating Units** in operation

B.6.1.4 The Generator shall submit a detailed schedule of tests to the **DNO** in accordance with the compliance testing requirements of EREC G99 and this Appendix.

B.6.1.5 Partial **Power Park Module** testing as defined in **B.6.2** and **B.6.3** is to be completed at the appropriate stage.

B.6.1.6 The **DNO** may permit relaxation from the requirement **B.6.2** to **B.6.8** where **manufacturers' information** for the **Power Park Module** has been provided which details the characteristics from tests on a representative installation with the same equipment and settings and the performance of the **Power Park Module** can, in the **DNOs** opinion, reasonably represent that of the installed **Power Park Module** at that site. For **Type C** and **Type D Power Park Modules** the relevant **Manufacturers' Information** must be supplied in the **Power Generating Module Document** or **DDRC** as applicable.

B.6.2 Pre 20% Synchronised Power Park Module Basic Voltage Control Tests

B.6.2.1 Before 20% of the **Power Park Module** has commissioned, either voltage

control test **B.6.5.6(i) or (ii)** must be completed.

B.6.3 Reactive Capability Test

B.6.3.1 This section details the procedure for demonstrating the reactive capability of a **Power Park Module** which provides all or a portion of the **Reactive Power** capability. These tests should be scheduled at a time where there are at least 95% of the **Generating Units** within the **Power Park Module** in service. There should be sufficient MW resource forecasted in order to generate at least 85% of **Registered Capacity** of the **Power Park Module**.

B.6.3.2 The tests shall be performed by modifying the voltage set-point of the voltage control scheme of the **Power Park Module** by the amount necessary to demonstrate the required reactive range. This is to be conducted for the operating points and durations specified in **B.6.4.5**.

B.6.3.2 In the case where the **Reactive Power** metering point is not at the same location as the **Reactive Power** capability requirement, then an equivalent **Reactive Power** capability for the metering point shall be agreed between the **Generator** and the **DNO**.

B.6.3.3 The following tests shall be completed:

- (i) Operation in excess of 60% **Registered capacity** and maximum continuous lagging **Reactive Power** for 30 minutes.
- (ii) Operation in excess of 60% **Registered capacity** and maximum continuous leading **Reactive Power** for 30 minutes.
- (iii) Operation at 50% **Registered capacity** and maximum continuous leading **Reactive Power** for 30 minutes.
- (iv) Operation at 20% **Registered capacity** and maximum continuous leading **Reactive Power** for 60 minutes.
- (v) Operation at 20% **Registered capacity** and maximum continuous lagging **Reactive Power** for 60 minutes.
- (vi) Operation at less than 20% **Registered capacity** and unity **Power Factor** for 5 minutes. This test only applies to systems which do not offer voltage control below 20% of **Registered capacity**.
- (vii) Operation at the lower of the **Minimum Generation** or 0% **Registered capacity** and maximum continuous leading **Reactive Power** for 5 minutes. This test only applies to systems which offer voltage control below 20% and hence establishes actual capability rather than required capability.
- (viii) Operation at the lower of the **Minimum Generation** or 0% **Registered capacity** and maximum continuous lagging **Reactive Power** for 5 minutes. This test only applies to systems which offer voltage control below 20% and hence establishes actual capability rather than required capability.

B.6.3.4 Within this Appendix lagging **Reactive Power** is the export of **Reactive Power** from the **Power Park Module** to the **DNO's system** and leading **Reactive Power** is the import of **Reactive Power** from the **DNO's system** to the **Power Park Module**.

B.6.4 Voltage Control Tests

B.6.4.1 This section details the procedure for conducting voltage control tests on **Power Park Modules** which provides all or a portion of the voltage control capability as described in the relevant technical requirements section of this EREC G99. These tests should be scheduled at a time when there are at least 95% of the **Generating Units** within the **Power Park Module** in service. There should be sufficient MW resource forecasted in order to generate at least 65% of **Maximum Capacity** of the **Power Park Module**.

B.6.4.2 The voltage control system shall be perturbed with a series of step injections to the **Power Park Module** voltage Setpoint, and where possible, multiple upstream transformer taps.

B.6.4.3 The time between transformer taps shall be at least 10 seconds as per **B.6.4 Figure B.6.1**.

B.6.4.4 For step injection into the **Power Park Module** voltage Setpoint, steps of $\pm 1\%$ and $\pm 2\%$ (or larger if required by the **DNO**) shall be applied to the voltage control system Setpoint summing junction. The injection shall be maintained for 10 seconds as per **B.6.4 Figure B.6.2**.

B.6.4.5 Where the voltage control system comprises of discretely switched plant and

apparatus additional tests will be required to demonstrate that its performance is in accordance with EREC G99 and the **Connection Agreement** requirements.

B.6.4.6 Tests to be completed:

(i)

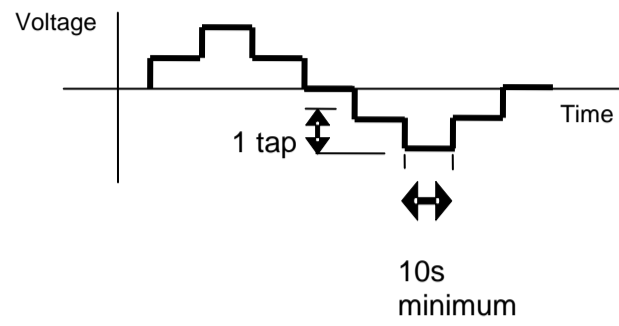

B.6.4 Figure B.6.1 – Transformer tap sequence for voltage control tests

(ii)

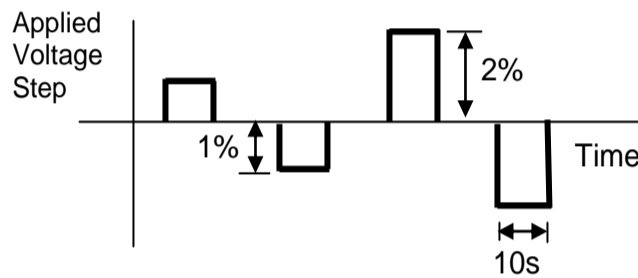

B.6.4 Figure B.6.2 – Step injection sequence for voltage control tests

B.6.5 Frequency Response Tests

B.6.5.1 This section describes the procedure for performing frequency response testing on a **Power Park Module**. These tests should be scheduled at a time where there are at least 95% of the **Generating Units** within the **Power Park Module** in service. There should be sufficient MW resource forecasted in order to generate at least 65% of **Registered Capacity** of the **Power Park Module**.

B.6.5.2 The frequency controller shall be in **Frequency Sensitive Mode** or **Limited Frequency Sensitive Mode** as appropriate for each test. Simulated frequency deviation signals shall be injected into the frequency controller setpoint/feedback summing junction. If the injected frequency signal replaces rather than sums with the real system frequency signal then the additional tests outlined in B.6.5.6 shall be performed with the **Power Park Module** or **Generating Unit** in normal **Frequency Sensitive Mode** monitoring actual system frequency, over a period of at least 10 minutes. The aim of this additional test is to verify that the control system correctly measures the real system frequency for normal variations over a period of time.

B.6.5.3 In addition to the frequency response requirements it is necessary to demonstrate the **Power Park Module** ability to deliver a requested steady state power output which is not affected by power source variation as per paragraph 13.12. This test shall be conducted in **Limited Frequency Sensitive Mode** at a part-loaded output for a period of 10 minutes as per B.6.5.6.

B.6.5.4 Preliminary Frequency Response Testing

B.6.5.5 Full Frequency Response Testing Schedule Witnessed by the **DNO**

B.6.5.6 The tests are to be conducted at a number of different Module Load Points (MLP) based on the maximum export limit (MEL). In the case of a **Power Park Module** the module load points are conducted as shown below unless agreed otherwise by the **DNO**.

Module Load Point 6 (Maximum Export Limit)	100% MEL
Module Load Point 5	90% MEL

Module Load Point 4 (Mid point of Operating Range)	80% MEL
Module Load Point 3	MRL+20%
Module Load Point 2	MRL+10%
Module Load Point 1 (Minimum Generation)	MRL

B.6.5.7 The tests are divided into the following two types;

- (i) Frequency response tests in Limited Frequency Sensitive Mode (LFSM) to demonstrate LFSM-O and LFSM-U capability as shown by B.6.5.8 Figure B.6.3.
- (ii) System islanding and step response tests as shown by B.6.6. Figure B.6.3.

B.6.5.8 There should be sufficient time allowed between tests for control systems to reach steady state (depending on available power resource). Where the diagram states 'HOLD' the current injection should be maintained until the **Active Power (MW)** output of the **Power Park Module** has stabilised. All frequency response tests should be removed over the same timescale for which they were applied. the **DNO** may require repeat tests should the response volume be affected by the available power, or if tests give unexpected results.

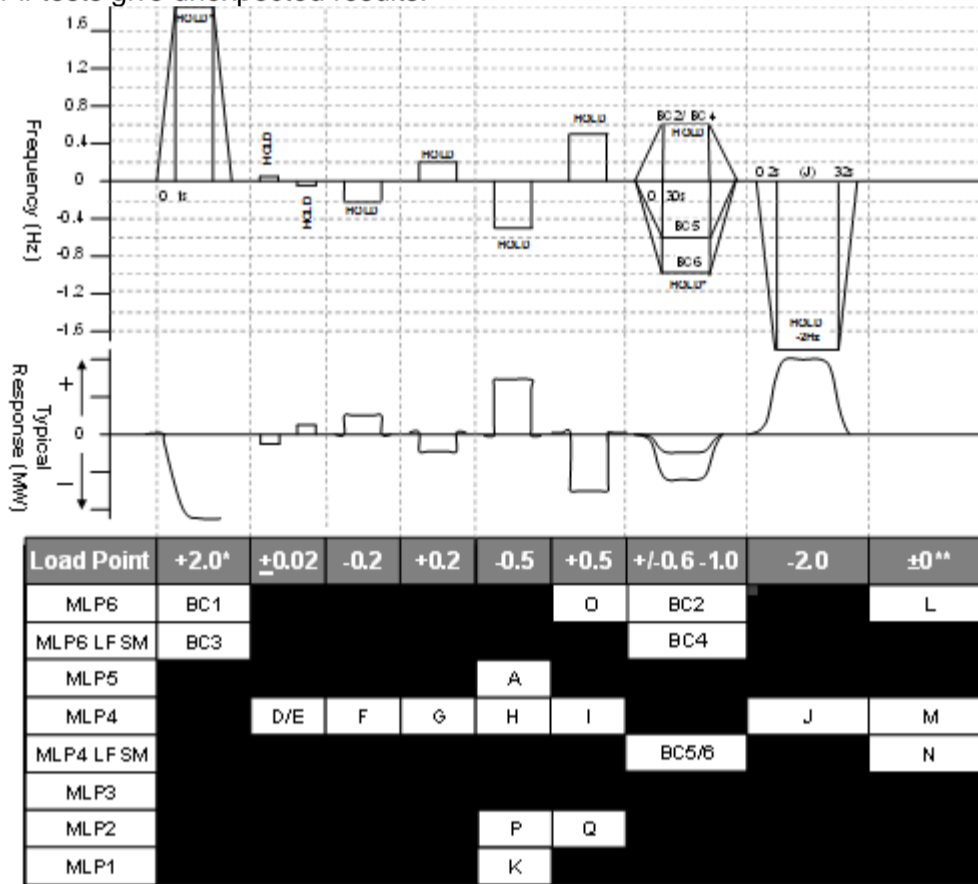

Figure B.6.2 – System islanding and step response tests

* This will generally be +2.0Hz unless an injection of this size causes a reduction in plant output that takes the operating point below **Minimum Generation** in which case an appropriate injection should be calculated in accordance with the following:

For example 0.9Hz is needed to take an initial output 65% to a final output of 20%. If the initial output was not 65% and the **Minimum Generation** is not 20% then the injected step should be adjusted accordingly as shown in the example given below

Initial Output 65%
Minimum Generation 20%
 Frequency Controller Droop 4%

$$\text{Frequency to be injected} = (0.65-0.20) \times 0.04 \times 50 = 0.9\text{Hz}$$

** Tests L and M in Figure B.6.3 shall be conducted if in this range of tests the system frequency feedback signal is replaced by the injection signal rather than the injection signal being added to the system frequency signal. The tests will consist of monitoring the **Power Park Module** in **Frequency Sensitive Mode** during normal system frequency variations without applying any injection. Test N in Figure B.6.3 shall be conducted in all cases. All tests should be conducted for a period of at least 10 minutes.

B.6.5.9 The target frequency adjustment facility should be demonstrated from the normal control point within the range of 49.9Hz to 50.1Hz by step changes to the target frequency setpoint.

B.6.6 **Fault Ride Through Testing**

B.6.6.1 This section describes the procedure for conducting fault ride through tests on a single **Generating Unit**.

B.6.6.2 The test circuit will utilise the full **Generating Unit** with no exclusions (eg in the case of a wind turbine it would include the full wind turbine structure) and shall be conducted with sufficient resource available to produce at least 95% of the **Registered Capacity** of the **Generating Unit**. The test will comprise a number of controlled short circuits applied to a test network to which the **Generating Unit** is connected, typically comprising of the **Generating Unit** transformer and a test impedance to shield the connected network from voltage dips at the **Generating Unit** terminals.

B.6.6.3 In each case the tests should demonstrate the minimum voltage at the **Generating Unit** terminals or **High Voltage** side of the **PGenerating Unit** transformer which the **Generating Unit** can withstand for the length of time specified in B.6.6.5. Any test results provided to the **DNO** should contain sufficient data pre and post fault in order to determine steady state values of all signals, and the power recovery timescales.

B.6.6.4 The following signals from either the **Generating Unit** terminals or **High Voltage** side of the **Generating Unit** transformer should be provided for this test only:

- (i) Phase voltages
- (ii) Positive phase sequence and negative phase sequence voltages
- (iii) Phase currents
- (iv) Positive phase sequence and negative phase sequence currents
- (v) Estimate of **Generating Unit** negative phase sequence impedance
- (vi) MW – **Active Power** at the power generating module.
- (vii) MVar – **Reactive Power** at the power generating module.
- (viii) Mechanical Rotor Speed
- (ix) Real / reactive, current / power Setpoint as appropriate
- (x) Fault ride through protection operation (e.g. a crowbar in the case of a doubly fed induction generator)
- (xi) Any other signals relevant to the control action of the fault ride through control deemed applicable for model validation.

At a suitable frequency rate for fault ride through tests as agreed with the **DNO**.

B.6.6.5 The tests should be conducted for the times and fault types indicated in **Table B.6.1**.

3 Phase	Phase to Phase	2 Phase to Earth	1 Phase to Earth	G99 Ref
0.14s	0.14s	0.14s	0.14s	12.3 & 13.4
0.384s				12.3 & 13.4
0.710s				
2.5s				
180.0s				

Table B.6.1 – Types of fault for fault ride through testing

Appendix C.1 Performance Requirements For Continuously Acting Automatic Excitation Control Systems For Type C and Type D Synchronous Power Generating Modules

C.1.1 Scope

C.1.1.1 This Appendix sets out the performance requirements of continuously acting automatic excitation control systems for **Type C** and **Type D Synchronous Power Generating Modules** that must be complied with by the **Generator**. This Appendix does not limit any site specific requirements where in the **DNO's** reasonable opinion these facilities are necessary for system reasons.

C.1.1.2 Where the requirements may vary the likely range of variation is given in this Appendix. It may be necessary to specify values outside this range where the **DNO** identifies a system need, and notwithstanding anything to the contrary the **DNO** may specify values outside of the ranges provided in this **Appendix C.1**. The most common variations are in the on-load excitation ceiling voltage requirements and the response time required of the **Exciter**. Actual values will be included in the **Connection Agreement**.

C.1.1.3 Should a **Generator** anticipate making a change to the excitation control system it shall notify the **DNO** as the **Generator** anticipates making the change. The change may require a revision to the **Connection Agreement**.

C.1.2 Requirements

C.1.2.1 The **Excitation System** of a **Type C** or **Type D Synchronous Power Generating Module** shall include an excitation source (**Exciter**) and a continuously acting **Automatic Voltage Regulator (AVR)** and shall meet the following functional specification.

C.1.2.3 Steady State Voltage Control

C.1.2.3.1 An accurate steady state control of the **Synchronous Power Generating Module** pre-set **Synchronous Generating Unit** terminal voltage is required. As a measure of the accuracy of the steady-state voltage control, the **Automatic Voltage Regulator** shall have static zero frequency gain, sufficient to limit the change in terminal voltage to a drop not exceeding 0.5% of rated terminal voltage, when the output of a **Synchronous Generating Unit** within a **Synchronous Power Generating Module** is gradually changed from zero to **Registered Capacity** at rated voltage and frequency.

C.1.2.4 Transient Voltage Control

C.1.2.4.1 For a step change from 90% to 100% of the nominal **Synchronous Generating Unit** terminal voltage, with the **Synchronous Generating Unit** on open circuit, the **Excitation System** response shall have a damped oscillatory characteristic. For this characteristic, the time for the **Synchronous Generating Unit** terminal voltage to first reach 100% shall be less than 0.6 seconds. Also, the time to settle within 5% of the voltage change shall be less than 3 seconds.

C.1.2.4.2 To ensure that adequate synchronising power is maintained, when the **Power Generating Module** is subjected to a large voltage disturbance, the **Exciter** whose output is varied by the **Automatic Voltage Regulator** shall be capable of providing its achievable upper and lower limit ceiling voltages to the **Synchronous Generating Unit** field in a time not exceeding that specified in the **Connection Agreement**. This will normally be not less than 50 ms and not greater than 300 ms. The achievable upper and lower limit ceiling voltages may be dependent on the voltage disturbance.

C.1.2.4.3 The **Exciter** shall be capable of attaining an **Excitation System On Load Positive Ceiling Voltage** of not less than a value specified in the **Connection Agreement** that will be:

not less than 2 per unit (pu)

normally not greater than 3 pu

exceptionally up to 4 pu

of **Rated Field Voltage** when responding to a sudden drop in voltage of 10 percent or more at the **Synchronous Generating Unit** terminals. **NGET** may specify a value outside the above limits where **NGET** identifies a system need.

C.1.2.4.4 If a static type **Exciter** is employed:

- (i) the field voltage should be capable of attaining a negative ceiling level specified in the **Connection Agreement** after the removal of the step disturbance of C.1.2.4.3. The specified value will be 80% of the value specified in C.1.2.4.3. The **DNO** may specify a value outside the above limits where the **DNO** identifies a system need.

- (ii) the **Exciter** must be capable of maintaining free firing when the **Synchronous Generating Unit** terminal voltage is depressed to a level which may be between 20% to 30% of rated terminal voltage.
- (iii) the **Exciter** shall be capable of attaining a positive ceiling voltage not less than 80% of the **Excitation System On Load Positive Ceiling Voltage** upon recovery of the **Synchronous Generating Unit** terminal voltage to 80% of rated terminal voltage following fault clearance. The **DNO** may specify a value outside the above limits where the **DNO** identifies a system need.

C.1.2.6 Overall **Excitation System** Control Characteristics

C.1.2.6.1 The overall **Excitation System** shall include elements that limit the bandwidth of the output signal. The bandwidth limiting must be consistent with the speed of response requirements and ensure that the highest frequency of response cannot excite torsional oscillations on other plant connected to the network. A bandwidth of 0-5 Hz will be judged to be acceptable for this application.

C.1.2.6.2 The response of the **Automatic Voltage Regulator** shall be demonstrated by injecting step signal disturbances into the **Automatic Voltage Regulator** reference. The **Automatic Voltage Regulator** shall include a facility to allow step injections into the **Automatic Voltage Regulator** voltage reference, with the **Type D Power Generating Module** operating at points specified by the **DNO** (up to rated MVA output). The damping shall be judged to be adequate if the corresponding **Active Power** response to the disturbances decays within two cycles of oscillation.

C.1.2.7 Under-Excitation Limiters

C.1.2.7.1 The security of the power system shall also be safeguarded by means of MVAR **Under Excitation Limiters** fitted to the **Synchronous Power Generating Module Excitation System**. The **Under Excitation Limiter** shall prevent the **Automatic Voltage Regulator** reducing the **Synchronous Generating Unit** excitation to a level which would endanger synchronous stability. The **Under Excitation Limiter** shall operate when the excitation system is providing automatic control. The **Under Excitation Limiter** shall respond to changes in the **Active Power** (MW) the **Reactive Power** (MVAR) and to the square of the **Synchronous Generating Unit** voltage in such a direction that an increase in voltage will permit an increase in leading MVAR. The characteristic of the **Under Excitation Limiter** shall be substantially linear from no-load to the maximum **Active Power** output of the **Power Generating Module** at any setting and shall be readily adjustable.

C.1.2.7.2 The performance of the **Under Excitation Limiter** shall be independent of the rate of change of the **Synchronous Power Generating Module** load and shall be demonstrated by testing as detailed in B.5.4.3. The resulting maximum overshoot in response to a step injection which operates the **Under Excitation Limiter** shall not exceed 4% of the **Synchronous Generating Unit** rated MVA. The operating point of the **Synchronous Generating Unit** shall be returned to a steady state value at the limit line and the final settling time shall not be greater than 5 seconds. When the step change in **Automatic Voltage Regulator** reference voltage is reversed, the field voltage should begin to respond without any delay and should not be held down by the **Under Excitation Limiter**. Operation into or out of the preset limit levels shall ensure that any resultant oscillations are damped so that the disturbance is within 0.5% of the **Synchronous Generating Unit** MVA rating within a period of 5 seconds.

C.1.2.7.3 The **Generator** shall also make provision to prevent the reduction of the **Synchronous Generating Unit** excitation to a level which would endanger synchronous stability when the **Excitation System** is under manual control.

C.1.2.8 Over-Excitation and Stator Current Limiters

C.1.2.8.1 The settings of the **Over-Excitation Limiter** and **stator current limiter**, shall ensure that the **Synchronous Generating Unit** excitation is not limited to less than the maximum value that can be achieved whilst ensuring the **Synchronous Generating Unit** is operating within its design limits. If the **Synchronous Generating Unit** excitation is reduced following a period of operation at a high level, the rate of reduction shall not exceed that required to remain within any time dependent operating characteristics of the **Synchronous Power Generating Module**.

C.1.2.8.2 The performance of the **Over-Excitation Limiter**—shall be demonstrated by testing as described in B.5.4.4. Any operation beyond the **Over-Excitation Limit** shall be controlled by the **Over-Excitation Limiter** or **stator current limiter** without the operation of any **Protection** that could trip the **Synchronous Power Generating Module**.

- C.1.2.8.3 The **Generator** shall also make provision to prevent any over-excitation restriction of the **Synchronous Generating Unit** when the **Excitation System** is under manual control, other than that necessary to ensure the **Power Generating Module** is operating within its design limits.

Appendix C.2 Performance Requirements for Continuously Acting Automatic Voltage Control Systems For Power Park Modules

C.2.1 Scope

C.2.1.1 This Appendix sets out the performance requirements of continuously acting automatic voltage control systems for **Type C** and **Type D Power Park Modules** that must be complied with by the **User**. This Appendix does not limit any site specific requirements where in the **DNO's** reasonable opinion these facilities are necessary for system reasons.

C.2.1.2 Should a **Generator** anticipate making a change to the excitation control system it shall notify the **DNO** as the **Generator** anticipates making the change. The change may require a revision to the **Connection Agreement**.

C.2.2 Requirements

C.2.2.1 The **DNO** requires that the continuously acting automatic voltage control system for the **Power Park Module** shall meet the following functional performance specification.

C.2.2.2 Steady State Voltage Control

C.2.2.2.1 The **Power Park Module** shall provide continuous steady state control of the voltage at the **Connection Point** with a **Setpoint Voltage** and **Slope** characteristic as illustrated in **Figure C.2.2.2a**.

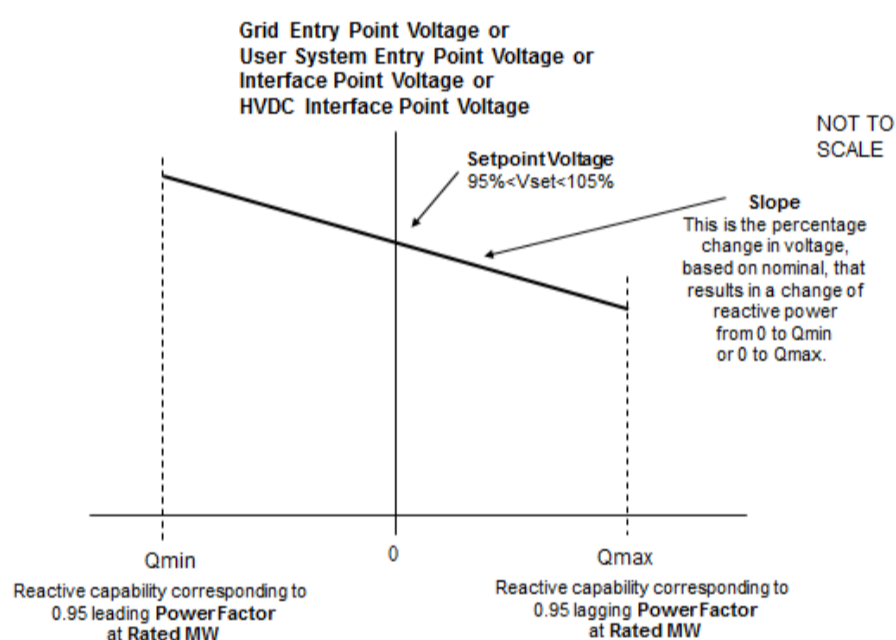

Figure C.2.2.2a

C.2.2.2.2 The continuously acting automatic control system shall be capable of operating to a **Setpoint Voltage** between 95% and 105% with a resolution of 0.25% of the nominal voltage. For the avoidance of doubt values of 95%, 95.25%, 95.5% may be specified, but not intermediate values. The initial **Setpoint Voltage** will be 100%. The tolerance within which this **Setpoint Voltage** shall be achieved is 0.25% and a Setpoint Voltage of 100%, the achieved value shall be between 99.75% and 100.25%. The **DNO** may request the **Generator** to implement an alternative **Setpoint Voltage** within the range of 95% to 105%.

C.2.2.2.3 The **Slope** characteristic of the continuously acting automatic control system shall be adjustable over the range 2% to 7% (with a resolution of 0.5%). For the avoidance of doubt values of 2%, 2.5%, 3% may be specified, but not intermediate values. The initial **Slope** setting will be 4%. The tolerance within which this **Slope** shall be achieved is 0.5% and a **Slope** setting of 4%, the achieved value shall be between 3.5% and 4.5%. The **DNO** may request the **Generator** to implement an alternative slope setting within the range of 2% to 7%.

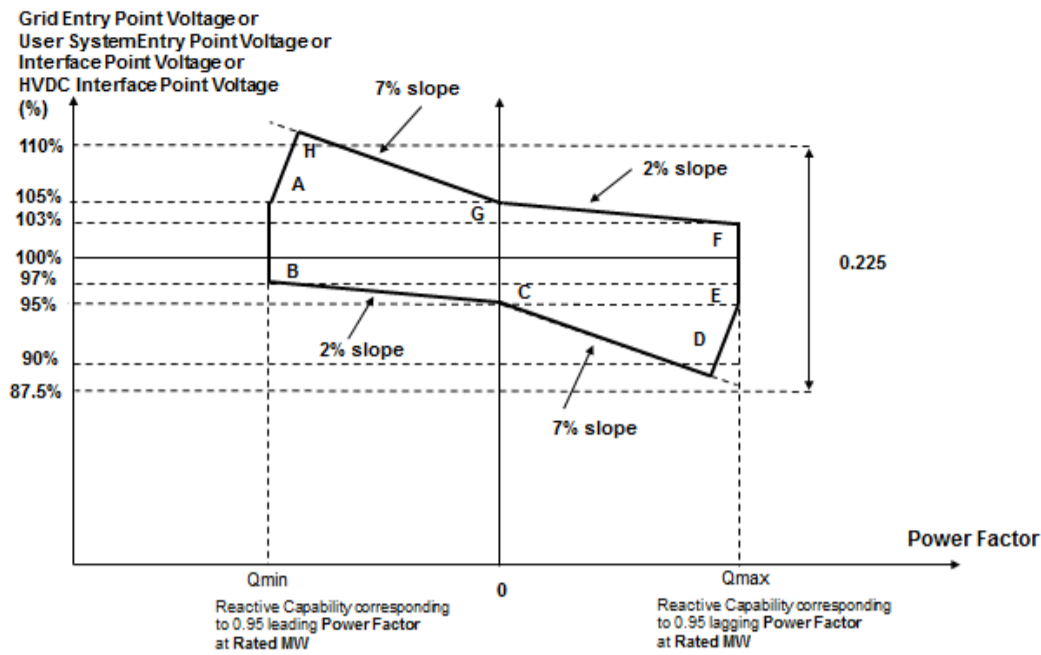

Figure C.2.2.2b

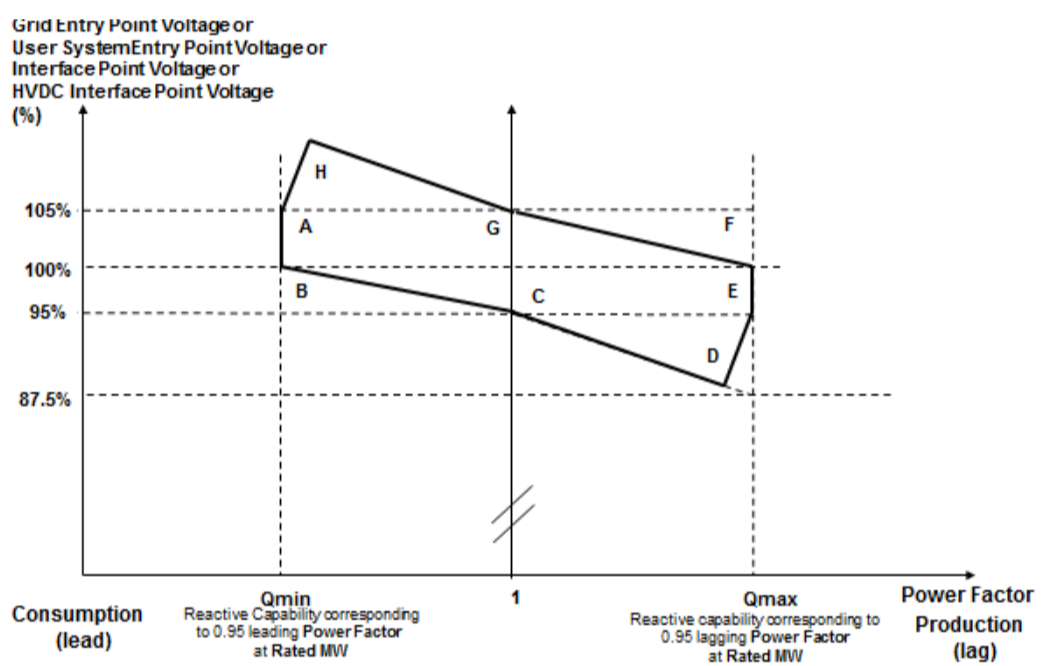

Figure C.2.2.2c

Comment [MK3]: This diagram needs updating to include interface Point

- C.2.2.2.4 **Figure C.2.2.2b** shows the required envelope of operation for **Power Park Modules**. **Figure C.2.2.2c** shows the required envelope of operation for **Power Park Modules** connected at 33kV and below. The enclosed area within points ABCDEFGH is the required capability range within which the **Slope** and **Setpoint Voltage** can be changed.
- C.2.2.2.5 Should the operating point of the **Power Park Module** deviate so that it is no longer a point on the operating characteristic (**figure C.2.2.2a**) defined by the target **Setpoint Voltage** and **Slope**, the continuously acting automatic voltage control system shall act progressively to return the value to a point on the required characteristic within 5 seconds.
- C.2.2.2.6 Should the **Reactive Power** output of the **Power Park Module** reach its maximum lagging limit at a **Connection Point** voltage above 95%, the **Power Park Module** maintain maximum lagging **Reactive Power** output for voltage reductions down to 95%. This requirement is indicated by the line EF in **figures C.2.2.2b** and **C.2.2.2c** as applicable. Should the **Reactive Power** output of the **Power Park Module** reach its maximum leading limit at a **Connection Point** voltage below 105%, the **Power Park Module** shall maintain maximum leading **Reactive Power** output for voltage increases up to 105%. This requirement is indicated by the line AB in **figures C.2.2.2b** and **C.2.2.2c** as applicable.

C.2.2.2.7 For **Connection Point** voltages below 95%, the lagging **Reactive Power** capability of the **Power Park Module** should be that which results from the supply of maximum lagging reactive current whilst ensuring the current remains within design operating limits. An example of the capability is shown by the line DE in figures C.2.2.2b and C.2.2.2c. For **Connection Point** voltages above 105%, the leading **Reactive Power** capability of the **Power Park Module** should be that which results from the supply of maximum leading reactive current whilst ensuring the current remains within design operating limits. An example of the capability is shown by the line AH in figures C.2.2.2b and C.2.2.2c as applicable. Should the **Reactive Power** output of the **Power Park Module** reach its maximum lagging limit at a **Connection Point** voltage below 95%, the **Power Park Module** shall maintain maximum lagging reactive current output for further voltage decreases. Should the **Reactive Power** output of the **Power Park Module** reach its maximum leading limit at a **Connection Point** voltage above 105%, the **Power Park Module** shall maintain maximum leading reactive current output for further voltage increases.

C.2.2.3 Transient Voltage Control

C.2.2.3.1 For an on-load step change in **Connection Point** voltage the continuously acting automatic control system shall respond according to the following minimum criteria:

- (i) the **Reactive Power** output response of the **Power Park Module** shall commence within 0.2 seconds of the application of the step. It shall progress linearly although variations from a linear characteristic shall be acceptable provided that the MVar seconds delivered at any time up to 1 second are at least those that would result from the response shown in figure C.2.2.3.1a.
- (ii) the response shall be such that 90% of the change in the **Reactive Power** output of the **Power Park Module** will be achieved within
 - 2 seconds, where the step is sufficiently large to require a change in the steady state **Reactive Power** output from its maximum leading value to its maximum lagging value or vice versa and
 - 1 second where the step is sufficiently large to require a change in the steady state **Reactive Power** output from zero to its maximum leading value or maximum lagging value as specified in paragraph 13.6;
- (iii) the magnitude of the **Reactive Power** output response produced within 1 second shall vary linearly in proportion to the magnitude of the step change.
- (iv) within 5 seconds from achieving 90% of the response as defined in C.2.2.3.1 (ii), the peak to peak magnitude of any oscillations shall be less than 5% of the change in steady state maximum **Reactive Power**.
- (v) following the transient response, the conditions of C.2.2.2 apply.

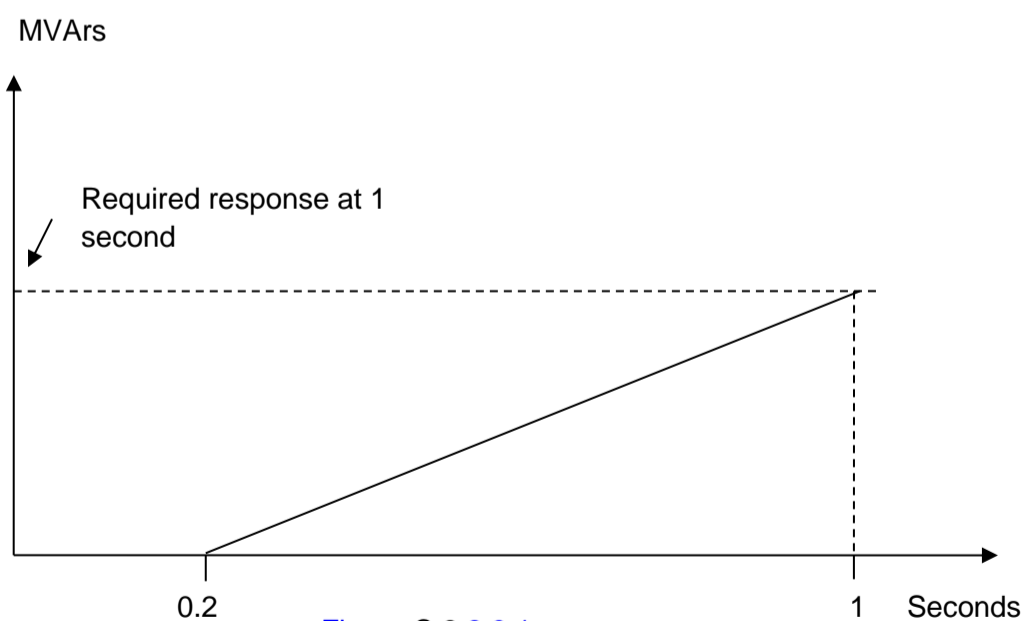

Figure C.2.2.3.1a

C.2.2.3.2 **Power Park Modules** shall be capable of

- (a) changing its **Reactive Power** output from its maximum lagging value to its maximum leading value, or vice versa, then reverting back to the initial level of **Reactive Power** output once every 15 seconds for at least 5 times within any 5 minute period; and
- (b) changing its **Reactive Power** output from zero to its maximum leading value then reverting back to zero **Reactive Power** output at least 25 times within any 24 hour period and from zero to its maximum lagging value then reverting back to zero **Reactive Power** output at least 25 times within any 24 hour period.

In all cases, the response shall be in accordance to **C.2.2.3.1** where the change in **Reactive Power** output is in response to an on-load step change in **Connection Point** voltage.

C.2.2.5 Overall Voltage Control System Characteristics

C.2.2.5.1 The continuously acting automatic voltage control system is required to respond to minor variations, steps, gradual changes or major variations in **Connection Point** voltage.

C.2.2.5.2 The overall voltage control system shall include elements that limit the bandwidth of the output signal. The bandwidth limiting must be consistent with the speed of response requirements and ensure that the highest frequency of response cannot excite torsional oscillations on other plant connected to the network. A bandwidth of 0-5Hz would be judged to be acceptable for this application. All other control systems employed within the **Power Park Module** should also meet this requirement

C.2.2.5.3 The response of the voltage control system shall be demonstrated by testing in accordance with **Appendix B.6**.

C.2.3 Reactive Power Control

C.2.3.1 As defined in Grid Code **ECC.6.3.8.3.4**, **Reactive Power** control mode of operation is not required in respect of **Power Park Modules** unless otherwise specified by the **NETSO** in coordination with the **DNO**. However where there is a requirement for **Reactive Power** control mode of operation, the following requirements shall apply.

C.2.3.2 The **Power Park** shall be capable of setting the **Reactive Power** setpoint anywhere in the **Reactive Power** range as specified in Grid Code **ECC.6.3.2.6** with setting steps no greater than 5 MVAR or 5% (whichever is smaller) of full **Reactive Power**, controlling the reactive power at the **Connection Point** to an accuracy within plus or minus 5MVAR or plus or minus 5% (whichever is smaller) of the full **Reactive Power**.

C.2.3.3 Any additional requirements for **Reactive Power** control mode of operation shall be specified by the **NETSO** in coordination with the **DNO**.

C.2.4 Power Factor Control

C.2.4.1 As defined in Grid Code **ECC.6.3.8.4.3**, **Power Factor** control mode of operation is not required in respect of **Power Park Modules** unless otherwise specified by the **NETSO** in coordination with the **DNO**. However where there is a requirement for **Power Factor** control mode of operation, the following requirements shall apply.

C.2.4.2 The **Power Park Module** shall be capable of controlling the **Power Factor** at the **Connection Point** within the required **Reactive Power** range as specified in Grid Code **ECC.6.3.2.2.1** and **ECC.6.3.2.4** to a specified target **Power Factor**. The **DNO** shall specify the target **Power Factor** value (which shall be achieved within 0.01 of the set **Power Factor**), its tolerance and the period of time to achieve the target **Power Factor** following a sudden change of **Active Power** output. The tolerance of the target **Power Factor** shall be expressed through the tolerance of its corresponding **Reactive Power**. This **Reactive Power** tolerance shall be expressed by either an absolute value or by a percentage of the maximum **Reactive Power** of the **Power Park Module**. The details of these requirements being pursuant to the terms of the **Connection Agreement**.

C.2.4.3 Any additional requirements for **Power Factor** control mode of operation shall be specified by the **NETSO** in coordination with the **DNO**.

Appendix C.3 Functional Specification for Fault Recording and Power Quality Monitoring Equipment

Functional Specification for Dynamic System Monitoring, Fault Recording and Power Quality Monitoring Equipment

C3.1 Purpose and Scope

This document describes the functional requirements for dynamic system monitoring, fault recording and power quality monitoring that Users need to provide in accordance with the requirements of ER G99 and the Distribution Code. It is expected that the functionality will be housed in a single recording device (RD), although other options are not discounted.

The requirements of this document apply to all Power Generating Facilities containing any Type C or Type D power generating modules.

C3.2 Functional Requirements

C3.2.1 Inputs and Outputs

The RD shall have analogue inputs:

- a) Three phase voltage
- b) Open delta/neutral-earth voltage
- c) Three phase current
- d) Neutral current.

The RD shall have digital inputs to record protection, control and plant status.

The number of inputs shall be sufficient to record these quantities at relevant points on the User's system as agreed with the DNO.

The RD shall have digital outputs:

- a) RD healthy
- b) RD triggered.

C3.2.2 Measured and Derived Quantities

At each agreed relevant point on the User's system dynamic system monitoring, fault recording and power quality monitoring shall be provided.

C3.2.2.1 Dynamic System Monitoring

Measured and derived quantities for dynamic system monitoring shall comprise:

- a) 3 phase voltage quantities, including positive and negative phase sequence values.
- b) 3 phase current quantities, including positive and negative phase sequence values.
- c) Real and Reactive power flows
- d) Frequency.

C3.2.2.2 Fault Recording

Measured and derived quantities for fault recording shall comprise:

- Voltage
- Current
- Protection, control and plant status.

C3.2.2.3 Power Quality Monitoring

Measured and derived quantities for power quality recording shall comprise:

- Frequency
- Voltage magnitude
- Short-term flicker
- Long-term flicker
- Voltage dips, swells and interruptions
- Voltage unbalance
- Voltage THD and harmonics
- Voltage inter-harmonics
- Rapid voltage change
- Voltage change
- Current magnitude

Current THD and harmonics
 Current inter-harmonics
 Current unbalance.

Measurement intervals shall be in accordance with IEC 62586-1 Table 6.

Power quality monitoring shall be compliant with BS EN 61000-4-30 Class A. The harmonic and inter-harmonic orders shall correspond with the those as specified in EREC G5, BS EN 50160 and BS EN 61000-4-7.

C3.2.3 Accuracy and Resolution

The accuracy and resolution requirements for dynamic system monitoring shall be a specified below.

Quantity	Measurement Range	Accuracy $\pm\%$ of nominal	Resolution y $\pm\%$ of nominal	Comment
RMS voltage	0 – 1.5V _n	0.1	0.01	Crest factor ≤ 1.5
Voltage phase sequence components	0.8 V _n – 1.5 V _n	0.1	0.01	Crest factor ≤ 1.5
Current phase sequence components	0 – 5.0 I _n	0.5	0.01	Crest factor ≤ 3.0
Active Power	0 – 5P _n	0.5	0.01	For all power factors between 0.5 and 1.0
Reactive Power	0 – 5RP _n	0.5	0.01	For all power factors between 0.87 and 1.0
Frequency	42.5Hz – 57.5Hz	0.005	0.001	20% < V _n < 150%

The accuracy requirements for fault recording and power quality monitoring shall be in accordance with BS EN 61000-4-30 Class A; the resolution requirements shall support the required accuracy in accordance with IEC 62586-1.

C3.2.4 Time Keeping

Inputs and all the derived data from inputs shall be time tagged to a resolution of 1 μ s.

The RD internal clock shall be synchronised with Universal Time (UTC) via GPS satellite or other functionally similar method. It should be possible to set a local time offset.

C3.2.5 Triggering

C3.2.5.1 Dynamic System Event Triggering

The dynamic system monitor shall have configurable dynamic system event triggers as follows:

- Frequency (half-cycle)
- Voltage (half cycle RMS and waveform)
- Current (half-cycle RMS and waveform)
- Positive sequence voltage (half cycle RMS)
- Negative sequence voltage (half cycle RMS)
- Active Power (half-cycle RMS)
- Reactive power (half-cycle RMS)
- Active power oscillation
- Power factor (half-cycle)
- Digital inputs.

Dynamic system event half-cycle triggering shall be as tabled below as a minimum requirement.

Parameter	Over (+)/ Under (-) Deviation (%)	Step (%)	Phase step (°)	Rate of Change
Frequency	• (+/-)	• (+/-)		• (+/-)
Voltage	• (+/-)	• (+/-)	• (+/-)	• (+/-)
Current	• (+/-)	• (+/-)		
Positive sequence voltage	• (+/-)			• (+/-)
Negative sequence voltage	• (+)			
Active Power	• (+/-)			• (+/-)
Reactive Power	• (+)	• (+/-)		
Power factor	• (+/-)			
Digital inputs	rising edge/falling edge			

Dynamic system event waveform triggering shall be as tabled below as a minimum requirement.

Parameter	Over (+)/ Under (-) Deviation (%)	Step (%)	Phase step (°)	Period	Number of oscillations in time window
Voltage waveform	• (+/-)	• (+/-)	•		
Current waveform	• (+/-)	• (+/-)	•		
Active power oscillation	• (+)			•	•
Digital inputs	rising edge/falling edge				

The above to have an accuracy of better than 2% and all analogue inputs shall trigger for disturbance durations shorter than 10ms.

Multiple triggering of fault recordings shall be prevented by a hysteresis band around the trigger set point.

The type and magnitude of triggering shall be independently selectable on all analogue input channels and on all calculated quantities.

Digital triggering shall be initialised by either the opening of a normally closed contact or the closing of a normally open contact. The required trigger mode shall be independently selectable on all channels. It shall be possible to deselect any channel so that it does not trigger the substation monitor. The manufacturer shall specify the voltage tolerances for a logic '1' and a logic '0'.

C3.2.5.1.1 Pre-event Recording

For dynamic system monitoring the pre-event time for half-cycle recording shall be DNO configurable in the range of 20ms to 1000ms; for waveform recording the pre-event time shall be DNO configurable in the range of 20ms to 200ms.

C3.2.5.1.2 Post-event Recording

For dynamic system monitoring the post-event time for half-cycle recording shall be DNO configurable in the range of 20ms to 60s; for waveform recording the post-event time shall be DNO configurable in the range of 20ms to 2000ms.

C3.2.5.2 Fault Event Triggering

The fault recorder shall have configurable dynamic system event triggers as follows:

Voltage (half cycle RMS and waveform)

Current (half-cycle RMS and waveform)

Digital inputs.

Fault recorder half-cycle triggering shall be as tabled below as a minimum requirement.

Parameter	Over (+)/ Under (-) Deviation (%)	Step (%)	Phase step (°)	Rate of Change
Voltage	• (+/-)	• (+/-)	• (+/-)	• (+/-)
Current	• (+/-)	• (+/-)		
Digital inputs	rising edge/falling edge			

Fault recorder waveform triggering shall be as tabled below as a minimum requirement.

Parameter	Over (+)/ Under (-) Deviation (%)	Step (%)	Phase step (°)
Voltage waveform	• (+/-)	• (+/-)	•
Current waveform	• (+/-)	• (+/-)	•
Digital inputs	rising edge/falling edge		

C3.2.5.2.1 Pre event Recoding:

For fault recording the pre-event time for half-cycle recording shall be DNO configurable in the range of 20ms to 120s; for waveform recording the pre-event time shall be DNO configurable in the range of 20ms to 200ms.

C3.2.5.2.2 Post event Recording

For fault recording the post-event time for half-cycle recording shall be DNO configurable in the range of 20ms to 120s; for waveform recording the post-event time shall be DNO configurable in the range of 20ms to 2000ms.

C3.2.5.3 Power Quality Event Triggering

The power quality monitor shall have configurable power quality event triggers as follows:

- Frequency (10 s)
- Voltage magnitude (10 minute)
- Short-term flicker (10 minute)
- Long-term flicker (2 hour)
- Voltage dip
- Voltage swell
- Voltage interruption
- Voltage unbalance (10 minute)
- Voltage THD and harmonics (10 minute)
- Voltage inter-harmonics (10 minute)
- Rapid voltage change
- Voltage change.

Power quality event triggering shall be as tabled below as a minimum.

Parameter	Over (+)/Under (-) Deviation
Frequency	• (+/-)
Voltage magnitude	• (+/-)
Short-term flicker	• (+)
Long-term flicker	• (+)
Voltage dip	• (-)
Voltage swell	• (+)
Voltage interruption	• (-)
Voltage unbalance	• (+)

Voltage THD and harmonics	• (+)
Voltage inter-harmonics	• (+)
Rapid voltage change	• (+/-)
Voltage change	• (+/-)

C3.2.6 Analysis and Reporting

C3.2.6.1 Dynamic System Records

Analysis software shall be provided to enable selection and plotting of each of the following dynamic system parameters against time:

- Frequency (half-cycle min, max and mean)
- Voltage (half cycle RMS min, max and mean)
- Current (half-cycle RMS min, max and mean)
- Positive sequence voltage (half cycle RMS)
- Negative sequence voltage (half cycle RMS min, max and mean)
- Active Power (half-cycle RMS min, max and mean)
- Reactive power (half-cycle RMS min, max and mean)
- Power factor (half-cycle).

The facility to graphically zoom in and out shall be provided.

Provision shall be made for display of:

- Dynamic system triggered event summary information in tabular form
- Dynamic system triggered event detail graphically
- Dynamic system triggered event occurrence versus time.

C3.2.6.2 Fault Records

Provision shall be made for display of:

- Fault recorder triggered event summary information in tabular form
- Fault recorder triggered event detail graphically
- Fault recorder triggered event occurrence versus time.

C3.2.6.3 Power Quality Records

Analysis software shall be provided to enable selection and plotting of each of the following power quality parameters against time:

- Frequency (10s min, max and mean)
- Voltage magnitude (10 minute min, max and mean)
- Short-term flicker (10 minute)
- Long-term flicker (2 hour)
- Voltage unbalance (10 minute)
- Voltage THD and harmonics (10 minute)
- Voltage inter-harmonics (10 minute).

The facility to graphically zoom in and out shall be provided.

Provision shall be made for display of:

- Power quality triggered event summary information in tabular form
- Voltage dips, swells and interruptions in residual voltage versus time graphical form and in the tabular form specified in BS EN 50160
- Power quality triggered events graphically
- Fault recorder triggered event occurrence versus time.

C3.2.7 Storage and communication

All data will be continuously stored.

Non-volatile static memory will be used to provide storage for a minimum of 28 days of data, prior to overwriting on a first in first out basis.

The source data files shall have an IEC 60255-24 COMTRADE and CSV format to allow transfer to other computer spread sheet programs or protection relay secondary test sets etc.

The Power Generating Facility Owner will specify what further communication options and protocols will be provided.

If the DNO requires the data to be transferred routinely or on demand to the DNO's SCADA, the DNO will provide further specific information on protocols and connection requirements.

C3.2.8 Environmental

The RD environmental performance shall be in accordance with IEC 62586-1 product coding PQI-A-FI2-H.

EMC emissions shall be in accordance with IEC 62586-1.

The minimum intrusion protection (IP) requirements shall be in accordance with IEC 62586-1.

C3.2.9 Additional Requirements

The following requirements specified in IEC 62586-1 shall apply:

- Start-up requirements
- Marking and operating instructions
- Functional, environmental and safety type tests
- EMC tests
- Climatic tests
- Mechanical tests
- Functional and uncertainty tests
- Routine tests
- Declarations
- Re-calibration and re-verification.

C3.3 Relevant Standards

The following standards are likely to be relevant. The Power Generating Facility Owner will quote all the standards the RD is compliant with.

EN 61000-4-3: Electromagnetic compatibility (EMC). Testing and measurement techniques. Radiated, radio-frequency, electromagnetic field immunity test.

IEC 60255-22-1: 'Electrical Relays - Electrical disturbance tests for measuring relays and protection equipment. 1MHz burst disturbance tests'.

IEC 61000-4-30: Electromagnetic compatibility (EMC). Part 4-30: Testing and measurement techniques – Power quality measurement methods.

BS EN 50160: Voltage characteristics of electricity supplied by public electricity networks.

BS EN 55011: Industrial, scientific and medical equipment. Radio frequency disturbance characteristics. Limits and methods of measurement.

BS EN 61000-4-6: Electromagnetic compatibility (EMC). Testing and measurement techniques. Immunity to conducted disturbances, induced by radio-frequency fields.

BS EN 61000-4-4: Electromagnetic compatibility (EMC). Testing and measurement techniques. Electrical fast transient/burst immunity test.

BS EN 61000-4-2: Electromagnetic compatibility (EMC). Testing and measurement techniques. Electrostatic discharge immunity test.

BS EN 61000-4-7 Testing and measurement techniques measurement immun harmonics and interharmonics measurements and instrumentation, for power supply systems and equipment

connected thereto

BS EN 60529: Specification for degrees of protection provided by enclosures (IP code).

BS EN ISO 9001: Quality management systems. Requirements

IEC 60870-5-101: Telecontrol equipment and systems. Transmission protocols. Companion standard for basic telecontrol tasks.

BS EN 60255-24: 'Electrical Relays. Common Format for Transient Data Exchange (COMTRADE) for Power Systems.'

BS EN 60255-27 Measuring relays and protection equipment. Product safety requirements.

ENA ER G5/4 Planning Levels for harmonic Voltage Distortion and the Connection of Non-Linear Equipment to Transmission Systems and Distribution Networks in the United Kingdom

IEC 62586-1 Power Quality Measurement in power systems – Part 1: Power quality instruments

C3.4 Calibration and Testing

It is the Power Generating Facility Owner's responsibility to ensure that the RD remains functioning and accurate. The DNO has the right to request demonstration of accuracy and functionality.

Correct operation of the RD will normally be demonstrated to the DNO when the Facility is commissioned.

Appendix D.1 Power Generating Module Decommissioning Confirmation

Confirmation of the decommissioning of a **Power Generating Module** connected in parallel with the public **Distribution Network** – in accordance with Engineering Recommendation G99.

Site Details		
Site Address (inc. post code)		
Telephone number		
MPAN(s)		
Distribution Network Operator (DNO)		
PGM Details		
Manufacturer and model type		
Serial number of each Generating Unit		
Rating (kVA)		
Type of prime mover and fuel source		
Decommissioning Agent Details		
Name		
Accreditation/Qualification:		
Address (incl post code)		
Contact person		
Telephone Number		
Fax Number		
E-mail address		
Name:	Signature:	Date:

Appendix D.2 Additional Information Relating to System Stability Studies

D.2.1 System Stability

Stability is an important issue for secure and reliable power system operation. Consequently **System Stability** considerations deserve attention when developing **Power Generating Module** connection design and operating criteria. Power **System Stability** is defined as the ability of a power system to remain in a state of operating equilibrium under normal operating conditions and to regain an acceptable state of equilibrium after it has been subjected to a disturbance. When subjected to a disturbance, the stability of the system depends on the initial system operating condition as well as the severity of the disturbance (eg small or large). Small disturbances in the form of load changes or operational network switching occur continually; the stable system must be able to adjust to the changing conditions and operate satisfactorily. The system must also be able to survive more severe disturbances, such as a short circuit or loss of a large **Power Generating Module**. If following a disturbance the system is unstable, it will usually experience a progressive increase in angular separation of synchronous **Generating Units'** rotors from the system, or an uncontrolled increase in the speed of asynchronous **Generating Units'** rotors, or a progressive decrease in system voltages. An unstable system condition could also lead to cascading outages and ultimately to a system blackout.

The loss of **System Stability** is often related to inability of synchronous **Generating Units** to remain in **Synchronism** after being subjected to a disturbance, either small or large. Loss of **Synchronism** can occur between one synchronous **Power Generating Modules** and the rest of the system, or between groups of synchronous **Power Generating Modules**, with **Synchronism** being maintained within each group after separating from each other. Small disturbances arise frequently as a result of normal load variations and switching operations. Such disturbances cause electro-mechanical rotor oscillations, which are generally damped out by the inertia of the **Generating Units**, system impedance and loads connected to the **Distribution Network**. Where damping is inadequate, **Power System Stabilisers** (PSSs) may offer a solution.

Undamped oscillations which result in sustained voltage and power swings, and even loss of **Synchronism** between synchronous **Power Generating Modules**, can arise following a small disturbance if either

- the transfer capability of the interconnecting **Distribution Network** is insufficient; or
- the control and load characteristics either singly or in combination are such that inadequate or negative damping, or reduced synchronising torque occurs.

Large disturbances, such as a 3-phase short circuit fault or circuit outage, can result in large excursions of synchronous **Power Generating Modules** rotor angles (ie angular separation) due to insufficient synchronising torque. The associated stability problem is then concerned with the ability of the system to maintain **Synchronism** when subjected to such a disturbance. Normally the most arduous case occurs when the summer minimum demand coincides with the maximum power output of the synchronous **Power Generating Module**.

During a fault the electrical output of each synchronous **Generating Unit** may be substantially less than the mechanical input power from its prime mover and the excess energy will cause the rotor to accelerate and increase the electrical angle relative to the power system. Provided that the fault is disconnected quickly, the synchronous **Power Generating Module** controls respond rapidly and with adequate **Distribution Network** connections remaining post-fault, the acceleration will be contained and stability maintained. Pole slipping could occur and if the acceleration is not contained, this will cause large cyclic exchanges of power between the synchronous **Power Generating Module** and the **Distribution Network**. These may damage synchronous **Power Generating Modules**, cause maloperation of **Distribution Network** protection and produce unacceptable voltage depressions in supply systems.

In the case of some types of **Power Park Modules**, the voltage depression on the local **Distribution Network** will cause acceleration of the rotor (increasing slip), with subsequent increased reactive demand. For prolonged faults this may cause the **Power Park Module** to go past its breakaway torque point and result in loss of stable operation and subsequent **Power Generating Module** disconnection

In the case of doubly fed asynchronous **Power Generating Modules** and series converter connected **Power Generating Modules**, a voltage depression on the local **Distribution Network** may cause the AC-DC-AC converter to rapidly disconnect, with subsequent fast disconnection of the machine leading to a potential loss of **System Stability**.

In the case of **Type C** and **Type D Power Generating Modules** the capability to ride through certain **Transmission System** faults is critical to **Distribution Network** and **Total System** stability.

Where larger synchronous **Power Generating Modules** are installed consideration should be given by the **Generator** and the **DNO** (in conjunction with **NETSO** where necessary) for the need to provide pole-slipping protection. The 'reach' (ie impedance locus) of any settings applied to such a protection should be agreed between the **Generator** and the **DNO**. The settings should be optimised, with the aim of rapidly disconnecting generation in the event of pole-slipping, whilst maintaining stability of the protection against other disturbances such as load changes.

Stability investigations for new **Power Generating Modules** will initially need to use data that has been estimated from Manufacturer's designs. On occasions, the machine size and/or equipment dynamic parameters change, and the studies may need to be repeated later during the project.

D.2.2 Clearance times

A **Distribution Network** can be subjected to a wide range of faults of which the location and fault type cannot be predicted. The **System Stability** should therefore be assessed for the fault type and location producing the most onerous conditions. It is recommended that three phase faults be considered.

The operating times of the equipment that have to detect and remove a fault from the system are critical to **System Stability**. Worst case situations for credible fault conditions will need to be studied, the fault locations selected for examination being dependent upon protection fault clearance times. Stability will normally be assessed on the basis of the slowest combination of the operating times of main protection signalling equipment and circuit breakers. Fault clearance times therefore need to include the operating times of protection relays, signalling, trip relays and circuit breakers.

Faster clearance times may become necessary where studies indicate that the risk to **System Stability** is unacceptable. Single phase to earth fault clearance times can be protracted but their effects on the **System Stability** are likely to be less disruptive than a three-phase fault. Each case to be studied should be considered on an individual basis in order to determine acceptable fault clearance times.

D.2.3 Power System Stabilizers

In general, **Power System Stabilisers** should provide positive system damping of oscillations in the frequency range from 0 to 5Hz. The gain of the **Power System Stabiliser** shall be such that an increase in the gain by a factor of at least 2 shall not cause instability. **Type C** and **Type D Power Generating Modules** will need to be studied in the context of the **Total System**, in conjunction with **NETSO**.

Voltage fluctuations resulting from inadequate damping of control systems require study at the **Point of Common Coupling (PCC)** and must be compliant with ER P28.

Appendix D.3 Loss of Mains (LoM) Protection Analysis

The following analysis for LoM protection includes the results of practical measurements. The attached analysis of the problem demonstrates the speed with which a **Generating Unit** can move out of **Synchronism** and the consequences for the unit of a reclosure on the **Distribution Network**.

D.3.1 Prime Mover Characteristics

A Modern **Generating Unit** can be of four types:-

1. **Synchronous Generating Unit:** Where the stator frequency defined by the rotational speed of the applied dc magnetic field in the rotor winding. The two being magnetically locked together, with the rotor magnetic field being at a slight advance (10-20 electrical degrees) of the Stator in order to generate. When connected to a large electrical network both will track the applied frequency. The electrical inertia constant H of the generator will be in the order of 3-5 seconds (time to decrease the frequency by 50% for a 100% increase in load).
2. **Asynchronous Generating Unit:** Where the stator frequency is determined by the large electrical network it is connected to. The rotating stator field then induces a rotating magnetic field in the rotor winding. To generate, this winding will be rotating at a marginally faster speed to this induced rotating frequency (-1 to -2% slip) in order to generate. The electrical inertia constant H of the generator will be in the order of 4-5 seconds.
3. **Doubly Fed Induction Generating Unit (DFIG):** Similar to the Asynchronous generator and usually found in wind turbines. Here the rotor is directly energised by a back to back voltage source converter (VSC). This creates in the rotor a variable frequency, in magnitude and phase, which allows the generator rotor to operate over a wider speed range than the 1-2% of an Asynchronous generator. Typically +/-20% speed range is possible. The electrical inertia of the generator is less clearly defined as the rotor is effectively decoupled from the stator, but typically it is given as 4 to 5 seconds before the secondary control systems can react in a similar time period.
4. **Converter Connected Generating Unit (CCGU):** Whilst the DFIG is partly coupled to the network through the stator, here the power source is completely hidden behind the converter and the generator is fully decoupled from the network. The electrical inertia of the generator is theoretically zero unless a degree of 'virtual inertia' is introduced into the converter control scheme, to make the generator behave as if it were closely coupled to the network.

Acceptable LoM protection systems are based on the Rate of Change of Frequency or RoCoF (of voltage)

which can arise from an imbalance between the power applied to the prime mover (and hence generator) and the power thus sent out into the network to supply load. There is a presumption, that an unbalance in load always exists when a generator is disconnected (Islanded) from the large electrical network. And this is then of sufficient magnitude to cause the generator to accelerate or de-accelerate (depending on its

electrical inertia constant H) so changing the frequency of the generated voltage at a sufficient rate to be detected. This is assumed to be in the order of 10%.

Even if the generator remains connected, sudden changes to the impedance of the distribution network, caused by switching, or a sudden load change, can have a similar but smaller effect until a new stable operating point is achieved. This is quite common, especially on weak (low fault level) overhead networks. This is not a LoM event, but is known to cause mal-operation of LoM relays unless properly accounted for.

The initial change in frequency following the change in load is essentially a function of the inertia constant H of the combination of the **Generating Unit** and its Prime Mover. The derivation of the transient frequency response is given in section 2 below.

Note that these equations only truly apply to generator types 1 and 2 and to the initial (1-2 second) response for type 3. For type 4 generators discussions with the generator manufacturer may be required to determine if any form of LoM relay would provide effective protection.

D.3.2 Analysis of Dynamic Behaviour of Generating Unit Following Load Change

The kinetic energy of a rotating **Generating Unit** and its prime mover is given by the equation

$$K = 5.48 \times 10^{-6} \times J \times N^2 \quad \text{equation 1}$$

where K = kinetic energy in kJ

J = moment of inertia in kgm²

N = machine in speed in rpm

From equation 1, the inertia constant (H) of the machine can be calculated using the expression,

$$H = \frac{K^1}{G} \quad \text{equation 2}$$

Where K¹ = Kinetic energy at rated speed and frequency (F_r)

G = kVA capacity of the **Generating Unit**

Hence at any frequency, F, the kinetic energy, K, can be expressed as

$$K = \left(\frac{F}{F_r} \right)^2 \times H \times G \quad \text{equation 3}$$

Now the immediate effect of any change in the power, P_c, being supplied by the **Generating Unit** is to initiate a change in the kinetic energy of the machine. In fact P_c is the differential of the kinetic energy with respect to time, thus

$$P_c = \frac{dK}{dt} \quad \text{equation 4}$$

Rewriting

$$P_c = \frac{dK}{dF} \times \frac{dF}{dt} \quad \text{equation 5}$$

Differentiating equation 3 gives

$$\frac{dK}{dF} = \frac{2FHG}{F_r^2} \quad \text{equation 6}$$

Substituting in equation 5

$$P_c = \frac{2FHG}{F_r^2} \times \frac{dF}{dt}$$

Re-arranging

$$\frac{dF}{dt} = \frac{P_c F_r^2}{2HGF} \quad \text{equation 7}$$

Appendix D.4 Main Statutory and Other Obligations

This appendix summarises the main statutory and other obligations on **DNOs**, **Generators** and **Customers** in relation to the design and operation of primary and protection equipment associated with **Distribution Networks**.

The key driver on the **DNO** is to ensure that it can comply with its statutory duties, and its regulatory obligations, in protecting its network, and disconnecting the minimum amount of equipment when unsafe situations have developed, as well as preserving supplies to other customers.

A key consideration of **Generators** and **Customers** is similarly to ensure that they can comply with their statutory duties to protect their entire network and to disconnect relevant equipment when unsafe situations have developed.

Reference	Obligation	DNO	Generator	Customer
ESQCR Reg 3	Ensure equipment is sufficient for purpose and electrically protected to prevent danger, so far as is reasonably practicable.	X	X	-
ESQCR Reg 4	Disclose information and co-operate with each other to ensure compliance with the ESQC Regulations 2002	X	X	-
ESQCR Reg 6	Apply protective devices to their network, so far as is reasonably practicable, to prevent overcurrents from exceeding equipment ratings.	X	X	-
ESQC Reg 7	Ensure continuity of the neutral conductor and not introduce any protective device in the neutral conductor or earthing connection of LV networks.	X	X	-
ESQCR Reg 8	Connect the network to earth at or as near as reasonably practicable to the source of voltage; the earth connection need only be made at one point.	X	X	-
ESQCR Reg 11	Take all reasonable precautions to minimise the risk of fire from substation equipment.	X	X	-
ESQCR Reg 21	Ensure that switched alternative sources of energy to distribution networks cannot operate in parallel with those networks and that such equipment which is part of an LV consumer's installation complies with BS 7671.		X	X

Reference	Obligation	DNO	Generator	Customer
ESQCR Reg 22	Not install or operate sources of energy in parallel with distribution networks unless there are: appropriate equipment, personnel and procedures to prevent danger, so far as is reasonably practicable; LV consumers' equipment complies with BS 7671; and specific requirements are agreed with the DNO .		X	X
ESQCR Reg 24	DNO equipment which is on a consumer's premises but not under the consumer's control is protected by a suitable fused cut-out or circuit breaker which is situated as close as reasonably practicable to the supply terminals, which is enclosed in a locked or sealed container.	X		
ESQCR Reg 25	Not give consent to making or altering of connections where there are reasonable grounds to believe that the consumer's installation does not comply with ESQCR / BS 7671 or, so far as is reasonably practicable, is not protected to prevent danger or interruption of supply.	X		
ESQCR Reg 27	Declare the number of phases, frequency and voltage of the supply and, save in exceptional circumstances, keep this within permitted variations.	X		
ESQCR Reg 28	Provide a written statement of the type and rating of protective devices.	X		
EAWR Reg 4	Construct systems including suitable protective devices that can handle the likely load and fault conditions.	X	X	X
EAWR Reg 5	Not put into service electrical equipment where its strength and capability may be exceeded in such a way as to pose a danger.	X	X	X
EAWR Reg 11	Provide an efficient and suitably located means to protect against excess current that would otherwise result in danger.	X	X	X

Reference	Obligation	DNO	Generator	Customer
MHSWR Reg 3	Carry out an assessment of risks to which employees are exposed to at work and risks to other persons not employed arising from the activities undertaken.	X	X	X
BS 7671	Provide protective devices to break overload/fault current in LV consumer installations before danger arises.			X
BS 7671	Take suitable precautions where a reduction in voltage, or loss and subsequent restoration of voltage, could cause danger.			X
Distribution Code DPC4.4.4	Incorporate protective devices in Distribution Networks in accordance with the requirements of the ESQCR.	X	X	X
	Agree protection systems, operating times, discrimination and sensitivity at the ownership boundary.	X	X	X
	Normally provide back-up protection in case of circuit breaker failure on HV systems.	X	X	X
Distribution Code DPC6.3	Customer's equipment must be compatible with DNO standards and practices.		X	X
	Design protection systems that take into account auto-reclosing or sequential switching features on the DNO network.		X	X
	Be aware that DNO protection arrangements may cause disconnection of one or two phases only of a three phase supply.		X	X
Distribution Code DPC8.10	Assess the transient overvoltage effects at the network ownership boundary, where necessary.	X	X	