

CIRCUIT BREAKER FAIL PROTECTION

This document is for Relevant Electrical Standards document only.

Disclaimer

NGG and NGET or their agents, servants or contractors do not accept any liability for any losses arising under or in connection with this information. This limit on liability applies to all and any claims in contract, tort (including negligence), misrepresentation (excluding fraudulent misrepresentation), breach of statutory duty or otherwise. This limit on liability does not exclude or restrict liability where prohibited by the law nor does it supersede the express terms of any related agreements."

TABLE OF CONTENTS

PURPOSE AND SCOPE	1
PART 1 – TECHNICAL REQUIREMENTS.....	1
1 FUNCTIONAL REQUIREMENTS.....	1
2 PERFORMANCE REQUIREMENTS.....	4
3 TEST REQUIREMENTS	4
4 FORMS AND RECORDS.....	11
PART 2 - DEFINITIONS AND DOCUMENT HISTORY	11
5 DEFINITIONS	11
6 AMENDMENTS RECORD	11
PART 3 - GUIDANCE NOTES AND APPENDICES.....	11
7 REFERENCES	11

PURPOSE AND SCOPE

This document describes the technical requirements for User's equipment directly connected to the England and Wales Transmission system within NGET's (National Grid Electricity Transmission) busbar protection zone. Nominal voltages of 400 kV, 275 kV, 132 kV and 66 kV apply unless otherwise agreed with the user as defined in the Bilateral agreement. This shall include all protection and control devices operating NGET Switchgear. The principles of this document also applies to the equipment connected at other voltages".

This Specification defines the technical requirements for Circuit Breaker Fail Protection.

PART 1 – TECHNICAL REQUIREMENTS

1 FUNCTIONAL REQUIREMENTS

General

- 1.1** Circuit breaker fail protection shall cause cessation of fault current within 300 ms of inception of the original fault whose detection initiated tripping of the failed circuit breaker.

Circuit Breaker Fail Detectors

- 1.2** Circuit breaker fail detector(s) shall be enabled when the protected circuit breaker has been called upon to trip by operation of its associated protection systems.
- 1.3** The detector(s) shall not operate if the circuit breaker fails to open during a routine switching operation or automatic switching sequence unless such failure coincides with or precipitates the development of a system fault, resulting in the operation of its associated protection systems.
- 1.4** A detector shall comprise the following:

- a) A current check element to check if current is still flowing in any phase of the circuit breaker following circuit breaker trip initiation.
- b) A timing element to delay tripping until the circuit breaker has had adequate time for normal extinction of fault current.

Informative: Acceptable arrangements of the current check element and timing element to form a detector are shown in Figures 3 and 4.

1.5 For Option A (see Fig. 3):

- a) The current check element shall be enabled by the circuit breaker fail initiating inputs to monitor the current flowing through the circuit breaker.
- b) Detection of current in any phase of the circuit breaker above setting shall start and maintain the timing element.
- c) A trip output from the detector shall be initiated if the current is still above setting at the end of the timing period.

1.6 For Option B (see Fig. 4):

- a) The timing element shall be started directly from the circuit breaker fail initiating inputs.
- b) The current check element shall be enabled by the timing element at the end of the timing period and shall monitor the current flowing through the circuit breaker.
- c) If the current in any phase of the circuit breaker is above setting, then a trip output from the detector shall be initiated.
- d) For applications using this arrangement, specific measures shall be taken to prevent unwanted back tripping for situations where the circuit breaker has been called upon to close when a trip relay (circuit breaker fail initiating contact) has been operated and not reset.

Informative: One such measure would be to block circuit breaker closing for the duration of trip relay operation.

1.7 The method of preventing unwanted back tripping shall be declared by the supplier.

Current Check Function

1.8 The function shall comply with IEC 60255-151.

1.9 The function shall have, as a minimum requirement, a current setting range of 5% to 25% in steps of 5% or 30% to 100% in steps of 10% depending upon the design of the circuit breaker. Additional step ranges may also be applicable as appropriate.

Informative: The setting range specified is based on the assumption that the rating of the current check element is 1 A and that the ratio of the current transformer is 2000/1000/1 at 400 kV and 1200/600/1 at 275 kV. However, a current rating of 5A and different CT ratios could equally apply.

Timing Function

1.10 The timing function shall comply with IEC 61810-1

1.11 The timing function shall have, as a minimum requirement, a time setting range of 50 ms to 250 ms in steps of 2 ms.

Circuit Breaker Fail System

- 1.12** Where the circuit breaker fail detector is a software function embedded in a multi-function numerical relay, such as busbar protection, one detector shall initiate tripping of contiguous circuit breakers.
- 1.13** Where the circuit breaker fail detector is affected by discrete conventional relays, two detectors operating in a two-out-of-two mode shall initiate tripping of contiguous circuit breakers.

Interfaces

- 1.14** Where the Circuit Breaker Fail Protection is not integrated with the busbar protection, it shall normally be supplied from a three phase set of measurement/protection class current transformers.
- 1.15** The circuit breaker fail protection shall be initiated by a single point digital output from each of the protection systems that can initiate tripping of the protected circuit breaker.

Informative: The single point digital input is normally a trip relay contact.

- 1.16** Inputs to the Circuit Breaker Fail Protection shall be immune from maloperation due to wiring earth faults.

Informative: Double pole switching is one accepted way of ensuring immunity from maloperation.

Outputs – Busbar Stations

- 1.17** The Circuit Breaker Fail Protection shall initiate back tripping of all other circuit breakers connected to the same busbar via the tripping system of the busbar protection.
- 1.18** Where the Circuit Breaker Fail Protection is not integrated with the busbar protection, a minimum of two single point outputs shall be provided to initiate backtripping.
- 1.19** The back tripping initiations shall be immune from maloperation due to wiring earth faults.

Informative: Double pole switching is one accepted way of ensuring immunity from maloperation.

- 1.20** Where the protection system is associated with a feeder circuit breaker such that tripping of directly connected remote circuit breaker(s) is required, then initiation shall be provided for the DTT and PTT, as provided for the feeder.

Informative: A typical logic diagram for a feeder circuit breaker fail protection system at a busbar substation is shown in Figure 5.

Outputs – Mesh Stations

- 1.21** The protection system shall be provided with single point outputs for each mesh corner to initiate back tripping of all associated local and directly connected remote circuit breakers.

Informative: An accepted way of initiating back tripping is to use the tripping system of both first and second mesh corner protections. A typical logic diagram for circuit breaker fail protection systems at a mesh substation is shown in figure 6.

Alarm Outputs

- 1.22** The following single point outputs shall be provided for the circuit breaker fail protection system alarms as appropriate:
- a) Circuit breaker fail protection operated.
 - b) Protection supply supervision.
 - c) Protection relay defective.
 - d) Trip relay operated indication, where a trip relay is provided.

2 PERFORMANCE REQUIREMENTS

Current Check Function

- 2.1** The operating time shall not be greater than 10 ms.
- 2.2** The drop off/pick up ratio shall not be less than 70%.
- 2.3** For 'Option A' the resetting time shall not be greater than 12 ms for operating currents of up to 30 times rating (ie 30 A) with a system X/R ratio of 40.
- Informative: This is the minimum time required to ensure the current check function resets quickly enough for the conditions specified above to prevent incorrect operation.
- 2.4** For 'Option B' the resetting time shall not be greater than 30 ms.
- 2.5** The error of the function shall not be greater than 5%.

Timing Function

- 2.6** The reset or disengage time of the function shall not be greater than 30 ms.
- 2.7** For 'Option A', only the overshoot of the function shall be not greater than 10 ms.

3 TEST REQUIREMENTS

- 3.1** The current check function shall be tested in accordance with the requirements of IEC 60255-151 to demonstrate that it meets the requirements of Clauses 4.1 to 4.5.
- 3.2** The timing function shall be tested in accordance with the requirements of IEC 61810-1 to demonstrate that it meets the requirements of Clauses 4.6 and 4.7.

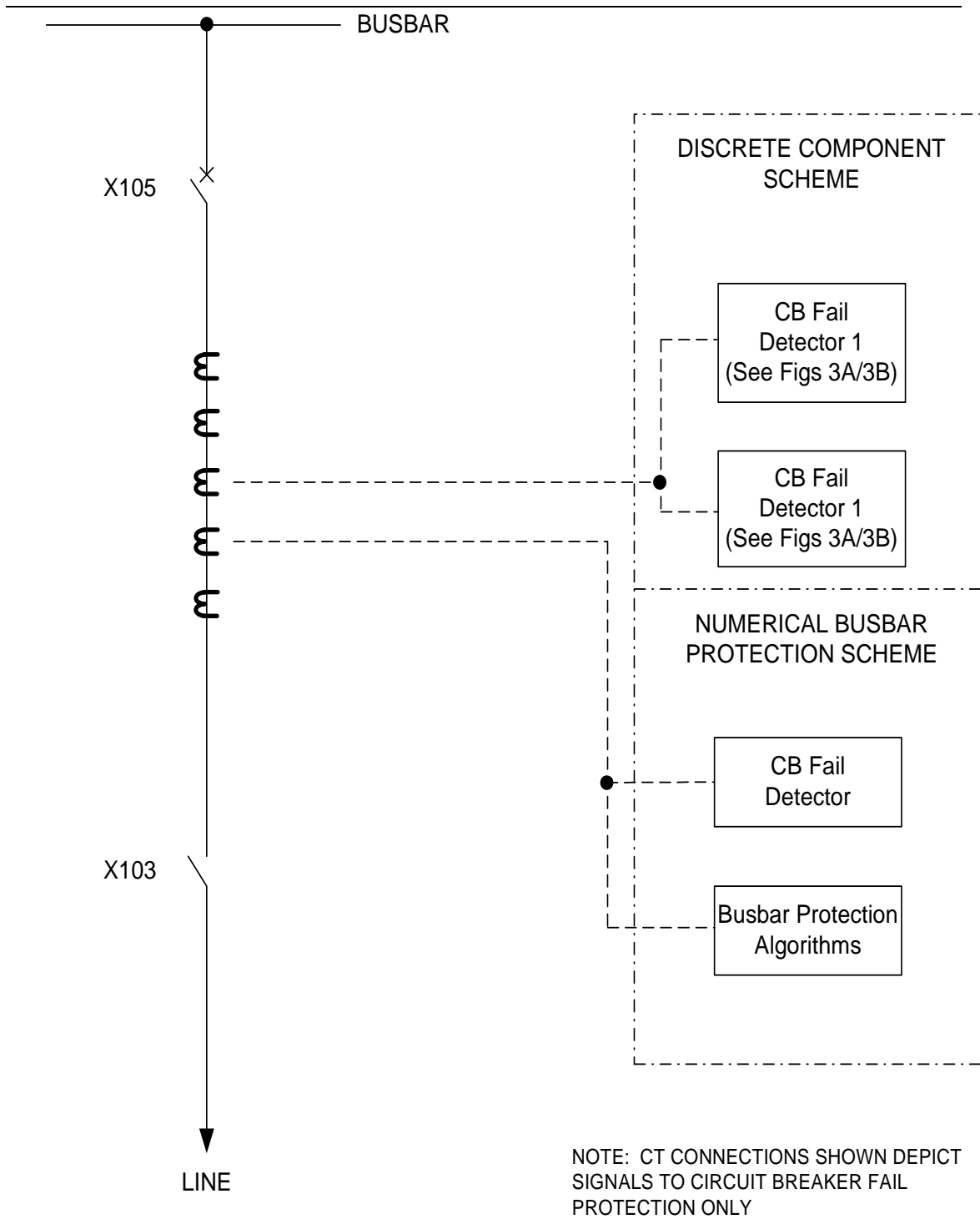

Figure 1: Typical CT Arrangement for Circuit Breaker Fail Protection for Busbar Stations - Feeder Circuit

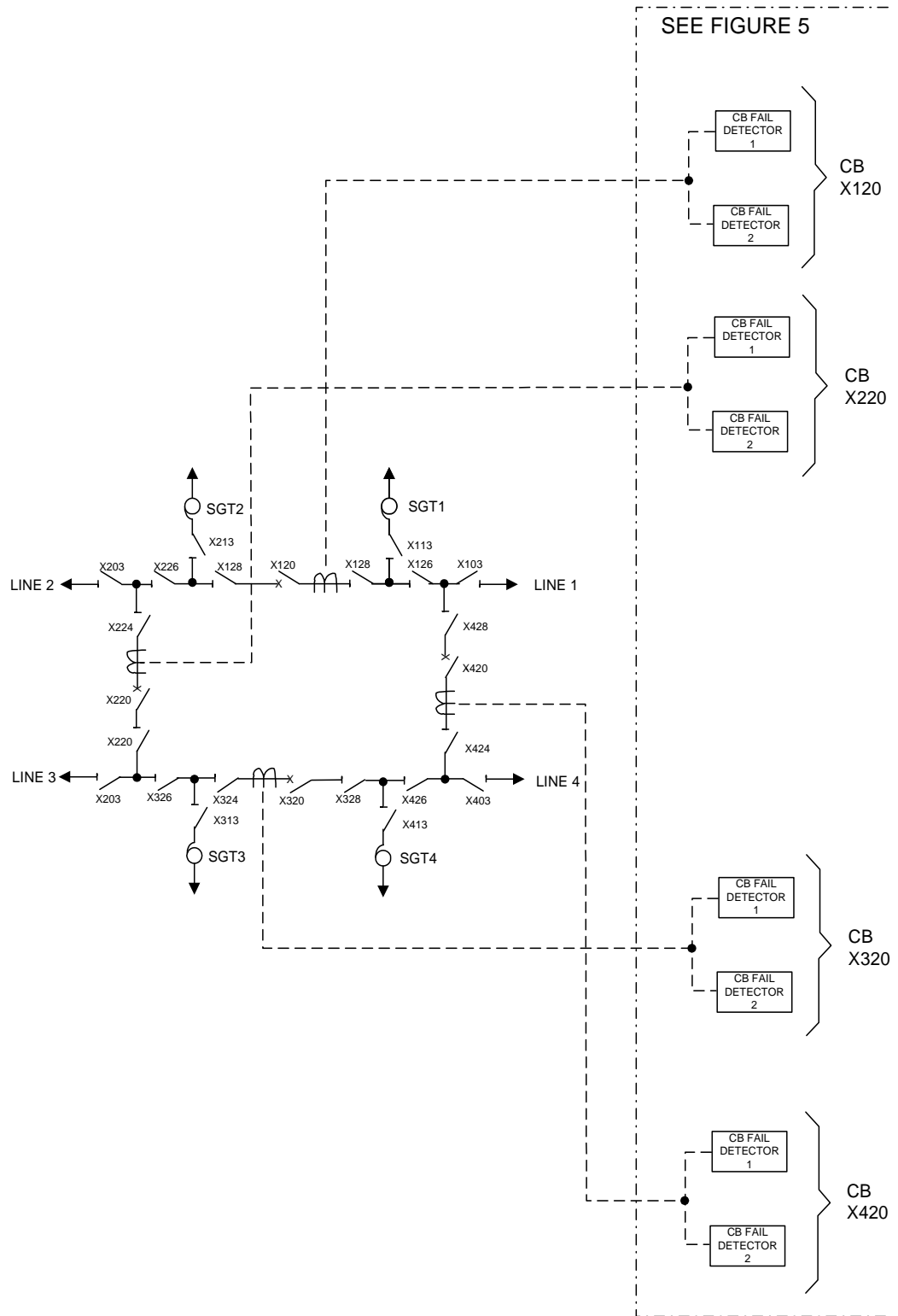

Figure 2: Typical CT Arrangement for Circuit Breaker fail Protection for Mesh Stations

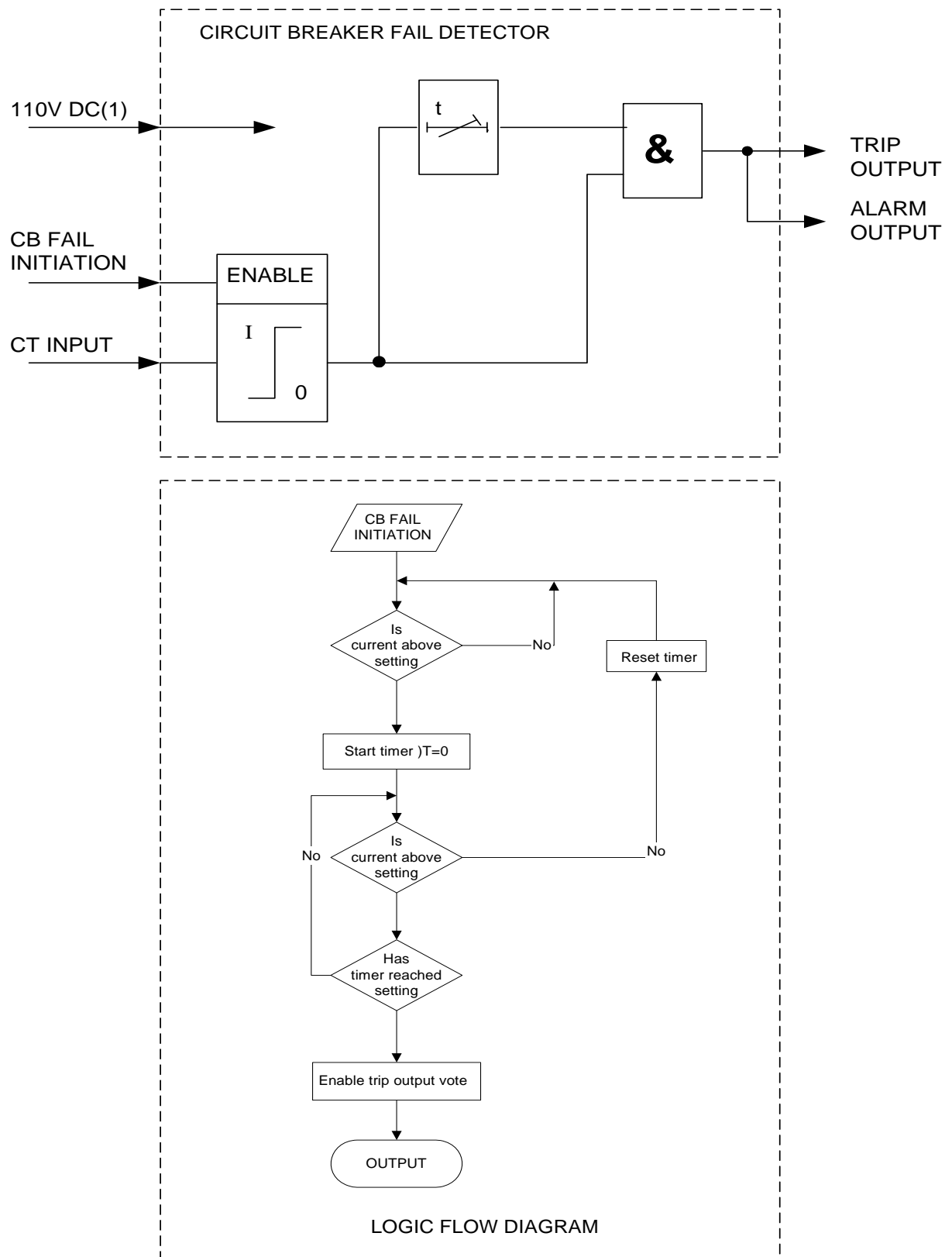

Figure 3: Circuit Breaker Fail Detector - Option A

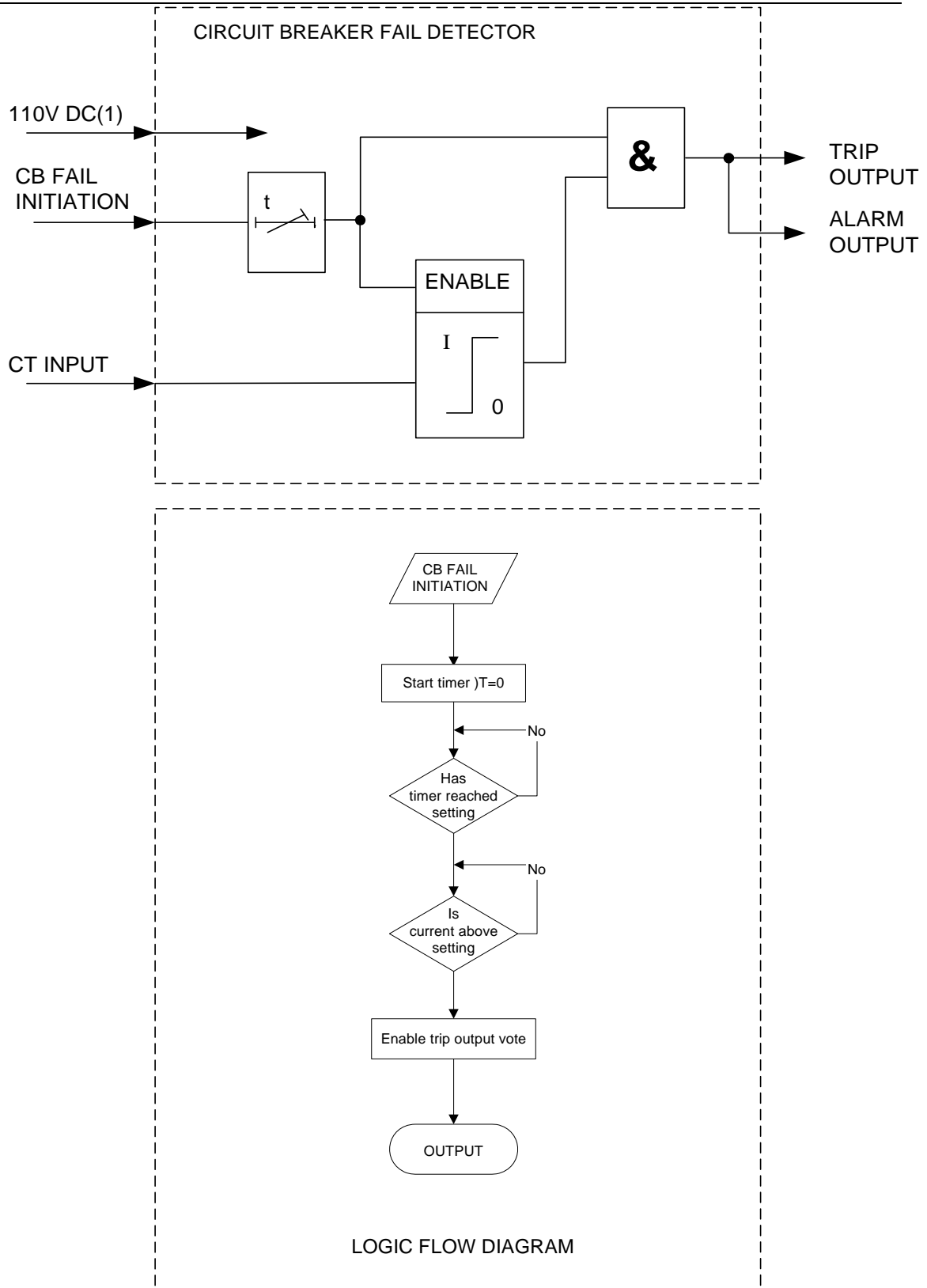
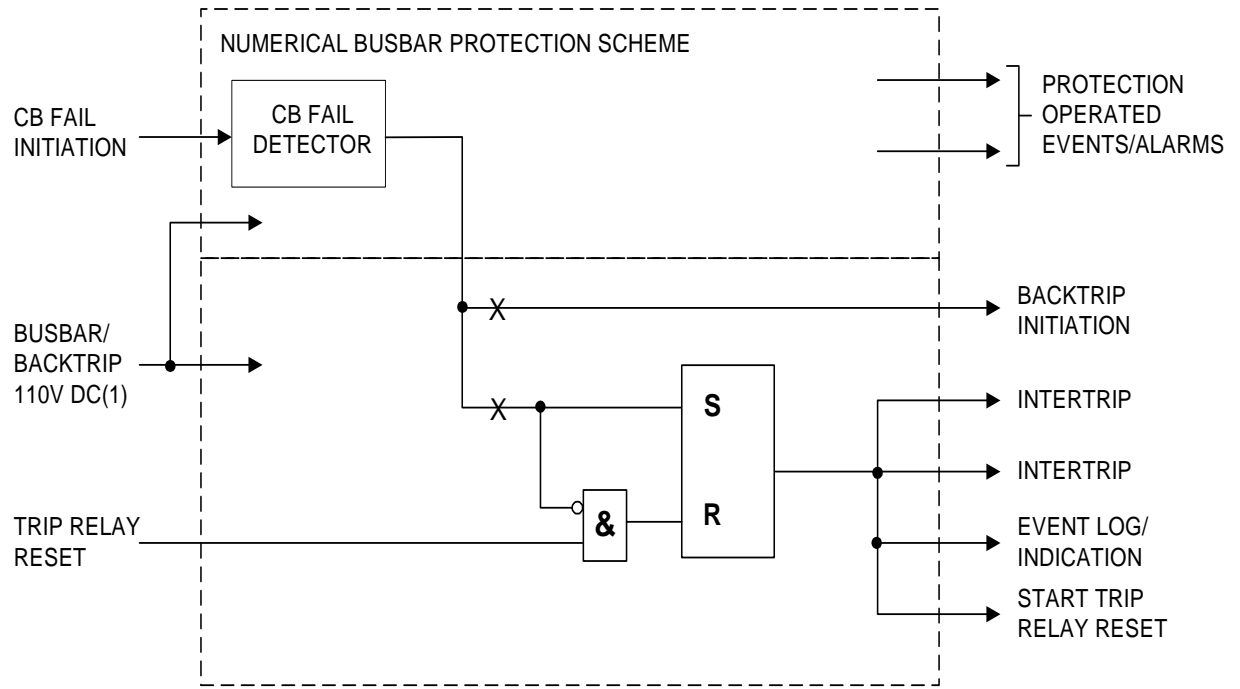

Figure 4: Circuit Breaker Fail Detector - Option B



NOTE:- —X— ISOLATABLE SIGNAL

Figure 5: Typical Tripping Logic Diagram for Circuit Breaker Fail Protection System for Busbar Substations - Feeder Circuit

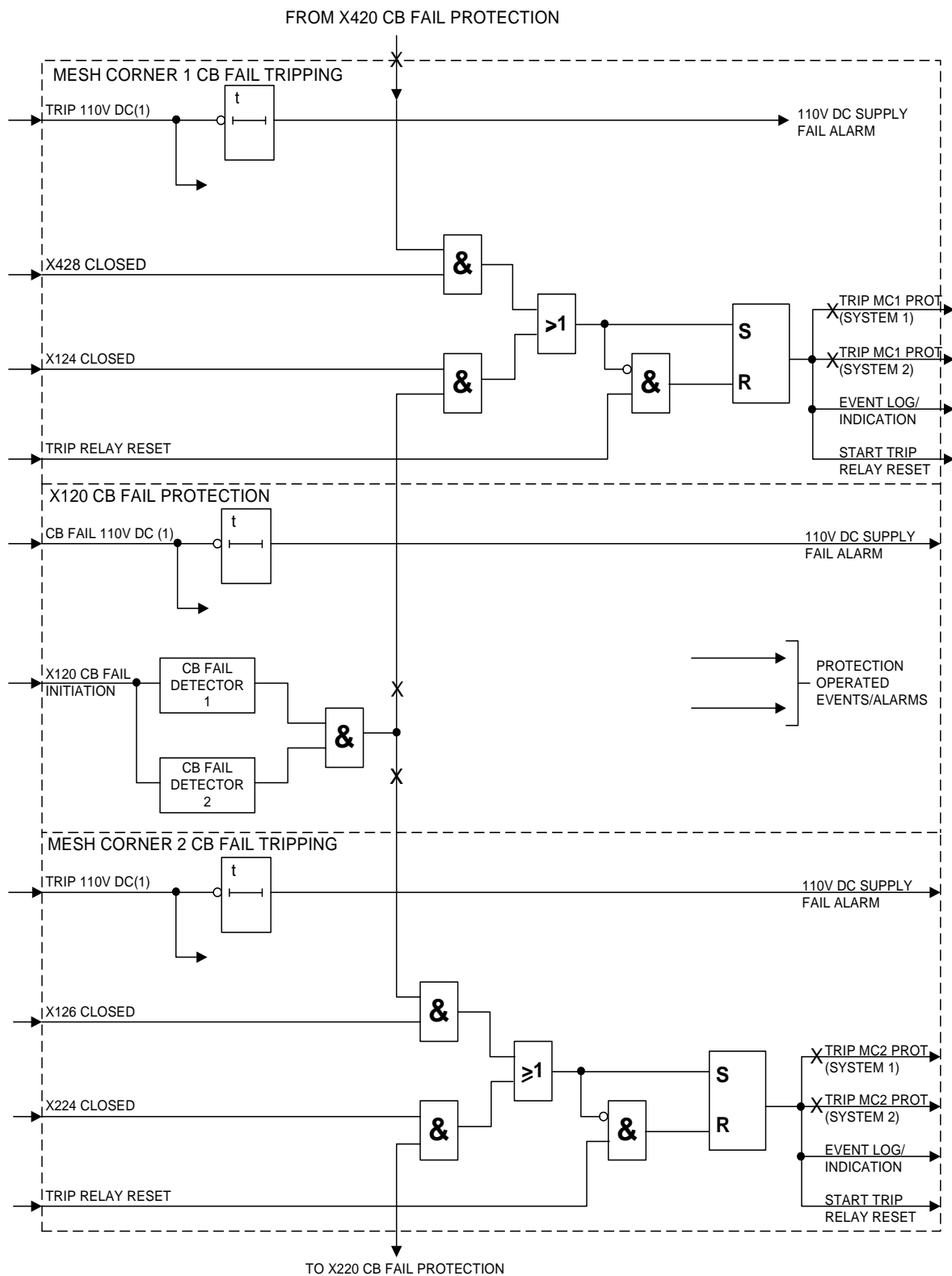

Figure 6: Part of Typical Tripping Logic Diagram for Circuit Breaker Fail Protection System for Mesh Substations

4 FORMS AND RECORDS

Not applicable.

PART 2 - DEFINITIONS AND DOCUMENT HISTORY

5 DEFINITIONS

Not applicable.

6 AMENDMENTS RECORD

Issue	Date	Summary of Changes / Reasons	Author(s)	Approved By (Inc. Job Title)
1	October 2014	New document	Richard Poole	GCRP

6.1 Procedure Review Date

5 years from publication date.

PART 3 - GUIDANCE NOTES AND APPENDICES

7 REFERENCES

IEC 61810-1	Electromechanical elementary relays- Part 1: General requirements – Edition 3.0
IEC 60255-151	Measuring relays and protection equipment – Part 151: Functional requirements for over/under current protection – Edition 1.0
IEC 60255-1	Measuring relays and protection equipment – Part 1: Common requirements – Edition 1.0
BS EN 255-22	Electrical Relays – Electrical Disturbance Tests for Measuring Relays and Protection Equipment – Radiated Electromagnetic Field Disturbance Tests
TS 1(RES)	Overview – National Grid System

© National Grid 2014

© 2014 Copyright owned by National Grid Electricity Transmission plc, all rights reserved.

No part of this publication may be reproduced in any material form (including photocopying and restoring in any medium or electronic means and whether or not transiently or incidentally) without the written permission of National Grid Electricity Transmission plc, except:

1. To the extent that any party who is required to comply (or is exempt from complying) with the provisions under the Electricity Act 1989 reasonably needs to reproduce this publication to undertake its licence or statutory duties within Great Britain (or any agent appointed so as to act on that party's behalf); and
2. In accordance with the provisions of the Copyright, Design's and Patents Act 1988.