

# GC0156 - Communication Infrastructure Subgroup Report

## Contents

Contents .....	1
Acronyms, key terms .....	2
Executive Summary.....	3
1) Introduction .....	4
1.1 Secretary of State Direction .....	4
1.2 GC0156 & Communication Infrastructure Subgroup .....	4
1.3 Terms of References .....	4
2) Telecommunication Interface .....	7
3) DNO – DER Telecommunication Interface.....	22
4) Communication option for DERs with non-resilient communication providers .....	25
5) Functional Specifications .....	26
5.1 Framework for Functional specifications.....	26
5.2 Functional specifications.....	26
6) Cost/Timeline to deliver action plan/discussion.....	31

**Acronyms, key terms**

DER	Distributed Energy Resource
DMS	Distribution Management System
DNO	Distribution Network Operator
DRZC	Distribution Restoration Zone Controller
EAD	Ethernet Access Direct
EC-RRG	Electronic Communications Resilience & Response Group
ESO	Electricity System Operator
ESRS	Electricity System Restoration Standard
NETSO	National Electricity Transmission System Operator
PMR	Private Mobile Radio
PSTN	Public Switched Telephone Network
RSP	Restoration Service Provider
RTU	Remote Terminal Units
TO	Transmission Owner

## **Executive Summary**

The ESO has been directed by the Secretary of State that in accordance with Special Condition 2.2 of the National Grid Electricity System Operator's Transmission Licence, The Electricity System Restoration Standard is set at –

- a) 60% of electricity demand being restored within 24 hours in all regions, and
- b) 100% of electricity demand being restored with 5 days nationally.

It is an essential requirement for the NETS to have electricity system restoration capability. The ESO delivers this requirement by determining and procuring sufficient system restoration capability for the NETS on an ongoing basis.

The purpose of this direction is to require that the ESO –

- a) Ensures and maintains an electricity restoration capability; and
- b) Ensures and maintains the restoration timeframe.

*Note: In accordance with the advice from BEIS- at GC0156 "electricity demand" will be calculated by way of the forecast of the next peak transmission demand.*

## **Objective**

The objective of this report is to cover proposed changes to the telecommunication requirements for network operators, TOs, OFTOs, CATOs, DNOs and contracted Restoration Service Providers and any other relevant parties required to facilitate the implementation of the Electricity System Restoration Standard (ESRS).

## **Proposals**

The definitions and proposals in this report included the following:

- ✓ Defined the current telecommunication interfaces used for restoration
- ✓ The future telecommunications requirement
- ✓ Identified telecommunication interface gaps but where the requirements are yet to be identified
- ✓ Proposed DNO- DER telecommunication interface ownership options for considerations
- ✓ Communication options for DERs with non-resilient telecommunication infrastructure
- ✓ Proposal for Telecommunications functional requirements for contracted parties.
- ✓ Identified functional requirements that should be specified at a later date
- ✓ Proposal for requirement to capture cost and timeline at a later date

## **Disagreements**

No disagreement was captured at the meetings.

## **Alternatives**

No alternative proposal was captured at the meetings

## 1) Introduction

### 1.1 Secretary of State Direction

The ESO has been directed by the Secretary of State that in accordance with Special Condition 2.2 of the National Grid Electricity System Operator's Transmission Licence, The Electricity System Restoration Standard is set at –

- a) 60% of electricity demand being restored within 24 hours in all regions, and
- b) 100% of electricity demand being restored with 5 days nationally.

It is an essential requirement for the NETS to have electricity system restoration capability. The ESO delivers this requirement by determining and procuring sufficient system restoration capability for the NETS on an ongoing basis.

The purpose of this direction is to require that the ESO –

- a) Ensures and maintains an electricity restoration capability; and
- b) Ensures and maintains the restoration timeframe.

*Note: "electricity demand" will be calculated by way of the forecast of the next peak transmission demand.*

### 1.2 GC0156 & Communication Infrastructure Subgroup

ESO has raised Grid Code change GC0156 to ensure that the industry is aware of what its needs to do to ensure and maintain an electricity restoration capability, and restoration timeframes.

This document presents the needs identified by the Communications Infrastructure Subgroup and their suggested implementation routes together with the relevant changes to Codes.

### 1.3 Terms of References

#### **Purpose/Scope**

To propose changes to the telecommunication requirements for network operators, TOs, OFTOs, DNOs, Restoration Service Providers and any other relevant parties required to facilitate the implementation of the Electricity Supply Restoration Standard (ESRS).

Assess and accept, or modify, the recommendations from ESRS working group report (including any unresolved ESRS WG comments) and create proposals to the GC0156 Working Group.

#### **Inputs**

- ESRS Communication Infrastructure Workgroup Report proposals.
- An understanding of the restoration process, demand restoration requirements, service provider (capacity rating, volumes, geographic distribution), and how these may change in the future.
- Consideration of the implications (if any) of the recent BT Openreach announcement re closure of telephone exchanges.

- Relevant codes and standards

**Outputs**

A report, to be delivered by 20<sup>th</sup> October 2022, covering all the above aspects, and including an appropriate level of detail, the following functional requirements for:

- Communications between the restoration service providers and the ESO and / or DNOs, CATOs, OFTOs and TOs
- Communications between CUSC parties and the ESO and / or host DSO, CATOs, OFTOs and TOs
- Communications between non CUSC Parties and host DSO.
- Communications between non restoration users and ESO and / or host DSO, CATOs, OFTOs and TOs
- Outline of new or changed standards for communications – both T & D
- Changes necessary to Grid Code and associated documents (eg Relevant Electrical Standards)
- Changes necessary to the Distribution Code and associated documents
- The proposals from the Communication Infrastructure Subgroup to the GC0156 Working Group
- An indication of timescale and estimated cost for the adoption of any proposals where this is available from subgroup members. Note – potential costs impacts will be forwarded to the Markets and Funding Mechanism Subgroup.
- Provide regular progress updates to GC0156 WG.
- Propose initial draft legal text for Grid Code and Distribution Code.

**Members (Update based on Nomination’s list)**

<b><u>Role</u></b>	<b><u>Name</u></b>	<b><u>Organization</u></b>
Chair		NGESO
Technical secretary		NGESO
Generator rep		
TO Rep		
DNO Rep		
Others		

**Standing Agenda**

1. Safety/Wellbeing/inclusion Moment
2. Actions Update
3. Progress/project update
4. Analysis and discussion of issues within scope

5. Risk/Issues for escalation to GC0156
6. Decisions/Actions
7. AOB

### **Logistics**

- **Cadence** –Meetings scheduled bi-weekly.
- **Duration** – 4 hours
- **Location** – Teams Meeting
- **Submissions** due and pre-read – slides/papers with clear confirmation of input/decisions needed 5 business days prior. Papers are to be read ahead of the meeting.
- **Minutes** – to be taken and circulated with the Action/decision Log
- **Quorum** – All standing members to attend. Deputies can attend with full decision-making authority delegated.
- **Disagreement** - Proposals will be based on majority decisions. Disagreement from the proposals shall be recorded.

## 2) Telecommunication Interface

### Transmission Led Restoration

The transmission led restoration communication map used in the Local Joint Restoration Plan (LJRP) is captured in Figure 1 below. This lists the active participants in the restoration process. The group reviewed and collated information from the participants. Further details of the interfaces are captured in Table 1. It was identified that there is a need to ensure that the end-to-end communication infrastructure can withstand up to 72 hours mains power failure to meet the ESRS standard.

Figure 1: Transmission led restoration communication map

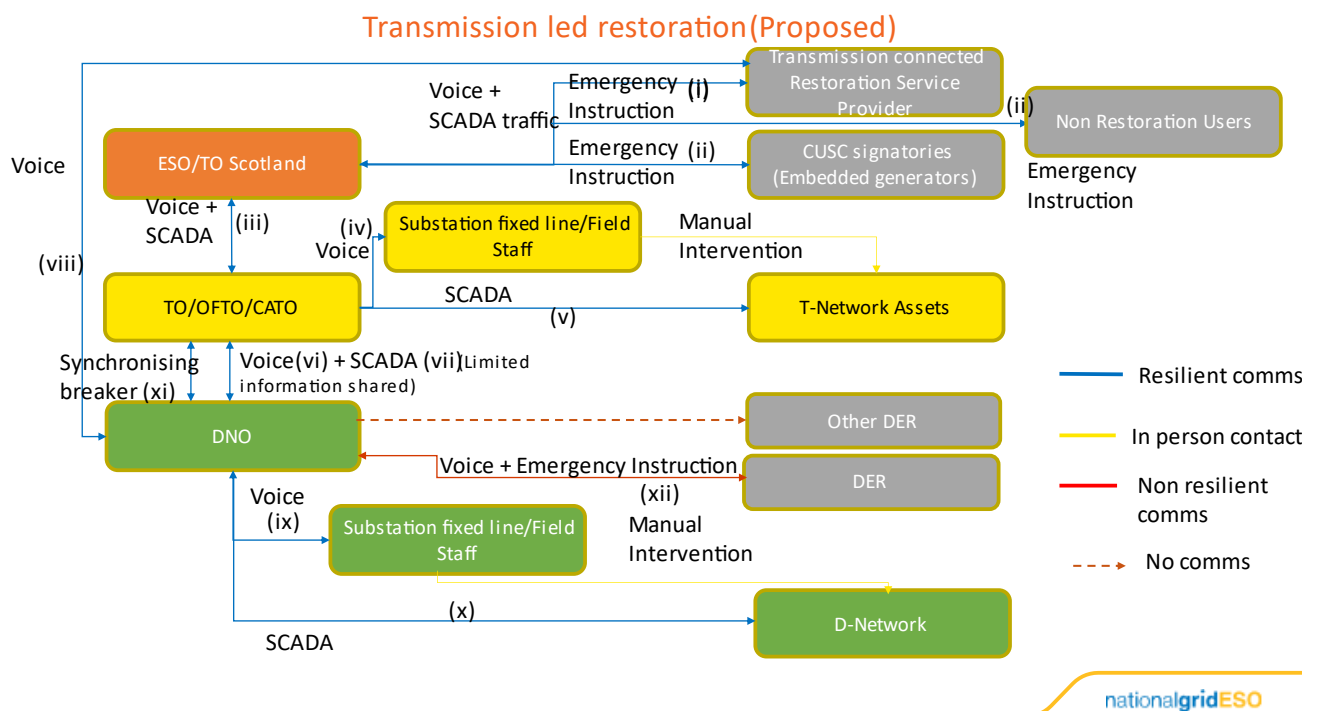

**Existing Interface Examples. These are not necessarily compliant with the ESRS Standards**

Label	A end	B end	Traffic Type	Interface	Status	Comments
i	ESO	Transmission connected restoration service provider	Voice	OpTel Fibre, Local Transmission Operator (TO) RTU, Call Manager	Installed	The Control Telephony Standard defines the functional specification for voice communication
i	ESO	Transmission connected restoration service provider	SCADA	OpTel Fibre, Local TO RTU	Installed	
ii	ESO	CUSC Signatories (embedded generation)/Transmission connected non restoration users	Voice	>Openreach EAD to TO Substation, >Telephony via DNO interconnect, Call Manager	Installed	DNO interconnect used in certain instance but by prior agreement. Utilising local DNO telephony system to route calls to generator.
ii	ESO	CUSC Signatories (embedded generation)/Transmission connected non restoration users	SCADA	>Openreach EAD to TO Substation, >SCADA via DNO interconnect, >	Installed	
iii	ESO	Transmission Operator (TO)	Voice	OpTel Fibre	Installed	
iii	ESO	Transmission Operator (TO)	SCADA	OpTel Fibre	Installed	
	TO	Field Staff (call out)	Voice	PSTN / Cellular, Airwave	in place currently. If no connectivity / comms - staff know to go to local office where control	Cellular does not offer 72 hours power autonomy while PSTN is being phased out and will no longer be available after 2025. Limited number of licensed operators have access to Airwave and plan is to phase out this service.



					telephony is available.	
iv	TO	Field Staff (on site)	Voice	OpTel Fibre, Cellular, Airwave	Installed	Cellular not subject to 72 hrs resilience. Limited number of licensed operators have access to Airwave and plan is to phase out service.
v	TO	TO assets	SCADA	OpTel Fibre	Installed	
vi	TO	DNO	Voice	Interconnect	Installed	
vii	TO	DNO	SCADA	OpTel Fibre, Operational Data Network (IP network over Fibre, EADS and Pilots)		TO RTU monitoring demand at the GSP
viii	DNO	TO connected RSP	Voice	OpTel / DNO interconnect	installed (black start phone)	
	DNO	Field Staff (call out)	Voice	PSTN / Cellular/PMR	in place currently	Cellular is not power resilient for 72 hrs. PSTN is being phased out and no longer available after 2025. Where self managed PMR capability is deployed it will be designed with appropriate power autonomy.
ix	DNO	Field Staff on site	Voice	PSTN / Cellular / internal phone	installed (current solution will need to be assessed for power resilience post PSTN switch off)	Cellular is not power resilient for 72. PSTN is being phased out and no longer available after 2025.
x	DNO	Distribution Network outside of DRZC	SCADA	Private radio / cellular /satellite, fibre		This will need to meet 72 hours mains independence requirements.

xi	TO	DNO	Synchronising breaker	substation internal wiring		
xii	DNO	DER	Voice	Self provide Private solution or third party commercial connections e.g., cellular or phone line.		All implementation for Anchor and Top up service providers will need to meet 72 hours mains independence requirements for the solution to be acceptable.

Table 1: Transmission led restoration Interface examples

## Distribution led restoration

The Distributed Restart project as part of its organisational design, reviewed and produced the distribution led restoration process map which listed the participants in the distribution led restoration process. The subgroup reviewed the distribution led restoration communication map produced by the Distributed Restart project and identified details of the existing and proposed interfaces required to implement the distribution restoration process. This is shown in Figure 2 below and detailed in Table 2.

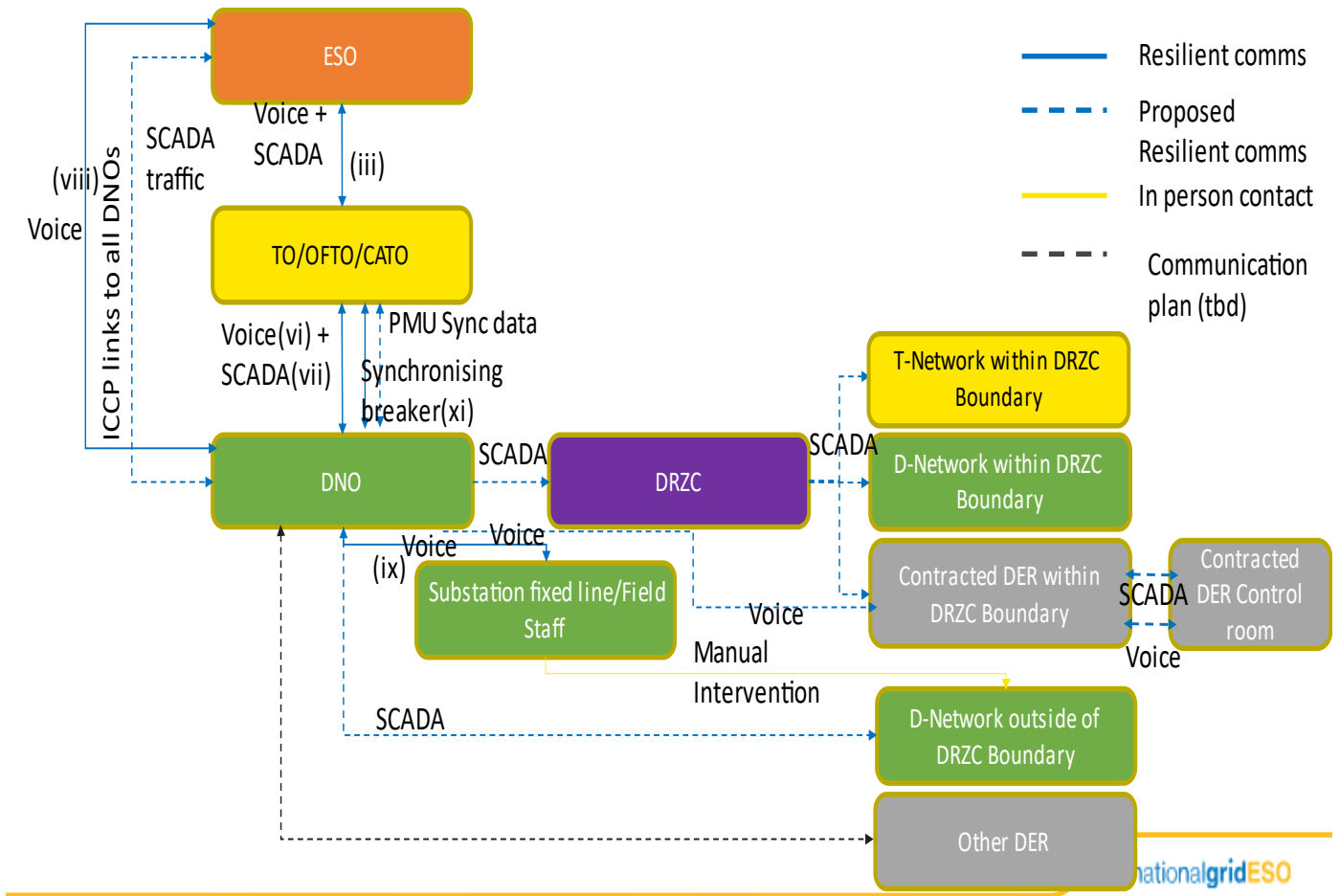

Figure 2: Proposed Distribution Led restoration communication map

### Distribution led restoration Interface.

Label	A end	B end	Traffic Type	Interface	Status	Comments
iii	ESO	TO	Voice	OpTel	Installed	
iii	ESO	TO	SCADA	OpTel	Installed	
vi	ESO	DNO	Voice	DNO interconnect (OpTel)	Installed	
	ESO	DNO	ICCP	OpTel	2Mb link via OpTel	Technical specification and interface needs defining. However, the physical connectivity is already in place on OpTel but the capacity will need provisioning. Routers/firewall/ hardware will need providing. This will be true for all DNOs.
vi	TO	DNO	Voice	DNO interconnect (OpTel), Cellular, Airwave	Installed	Cellular does not offer 72 hours power autonomy Limited number of licensed operators have access to Airwave and plan is to phase out this service.
vii	TO	DNO	SCADA	At Grid supply points TOs can monitor the demand from DNO	Installed.	
	TO	DNO	Synchronisation using Phasor Measurement Units (PMU)	TBC	New interface	Technical specification and interface needs defining. Once the latency and bandwidth requirements and power resilience are known any technology can be used that meets the needs case. It also needs to be clarified what is to be synchronised during each phase of restoration i.e. Anchor to DRSP to TO RSP.
	DNO	DRZC	SCADA	TBC	New interface	Technical specification and interface needs defining.
	DNO	Field Staff (call out)	Voice	PSTN / Cellular, Airwave	in place currently	This will need to meet 72 hours mains independence requirements. Alternatively, a process put in place to get field engineers to site where voice communication exists. Cellular does not offer 72 hours power autonomy while PSTN is being phased out and will no longer be available after 2025. Limited number of licensed operators

Label	A end	B end	Traffic Type	Interface	Status	Comments
						have access to Airwave and plan is to phase out this service.
ix	DNO	Field Staff on site	Voice	PSTN / Cellular / internal phone, Airwave	Installed (current solution will need to be assessed for power resilience post PSTN switch off)	Cellular does not offer 72 hours power autonomy while PSTN is being phased out and will no longer be available after 2025. Limited number of licensed operators have access to Airwave and plan is to phase out this service.
x	DNO	Distribution Network outside of DRZC boundary	SCADA	Private network / commercial network	Installed (current solution will need to be assessed for power resilience post PSTN switch off)	Primary substations to have 72 hours power resilience. Commercial communications networks do not offer power autonomy for 72 hrs with the withdrawal of PSTN.
	DRZC	Transmission Network within DRZC boundary	SCADA	TBC	Not defined	Technical specification and interface needs defining.
x	DRZC	Distribution Network within DRZC boundary	SCADA	TBC	Not defined	Technical specification and interface to be defined - see proposals below
	DRZC	DER within DRZC boundary	SCADA	TBC	not defined	Technical specification and interface to be defined – see proposals below
xi	TO	DNO	Synchronising Breaker			Synchronising the network between DNO- TO or DNO-DNO could be done by using PMU or

Label	A end	B end	Traffic Type	Interface	Status	Comments
						equivalent. Then the functional specification of comms medium between the PMUs will be defined by team led by DNOs as part of DRZC Specification.

Table 2: Distribution led restoration Interface.

Figure 3 shows the restoration communication map for the entire restoration process that comprises of both the transmission and distribution restoration process. The subgroup reviewed the interfaces between the participants and added the details where this exists.

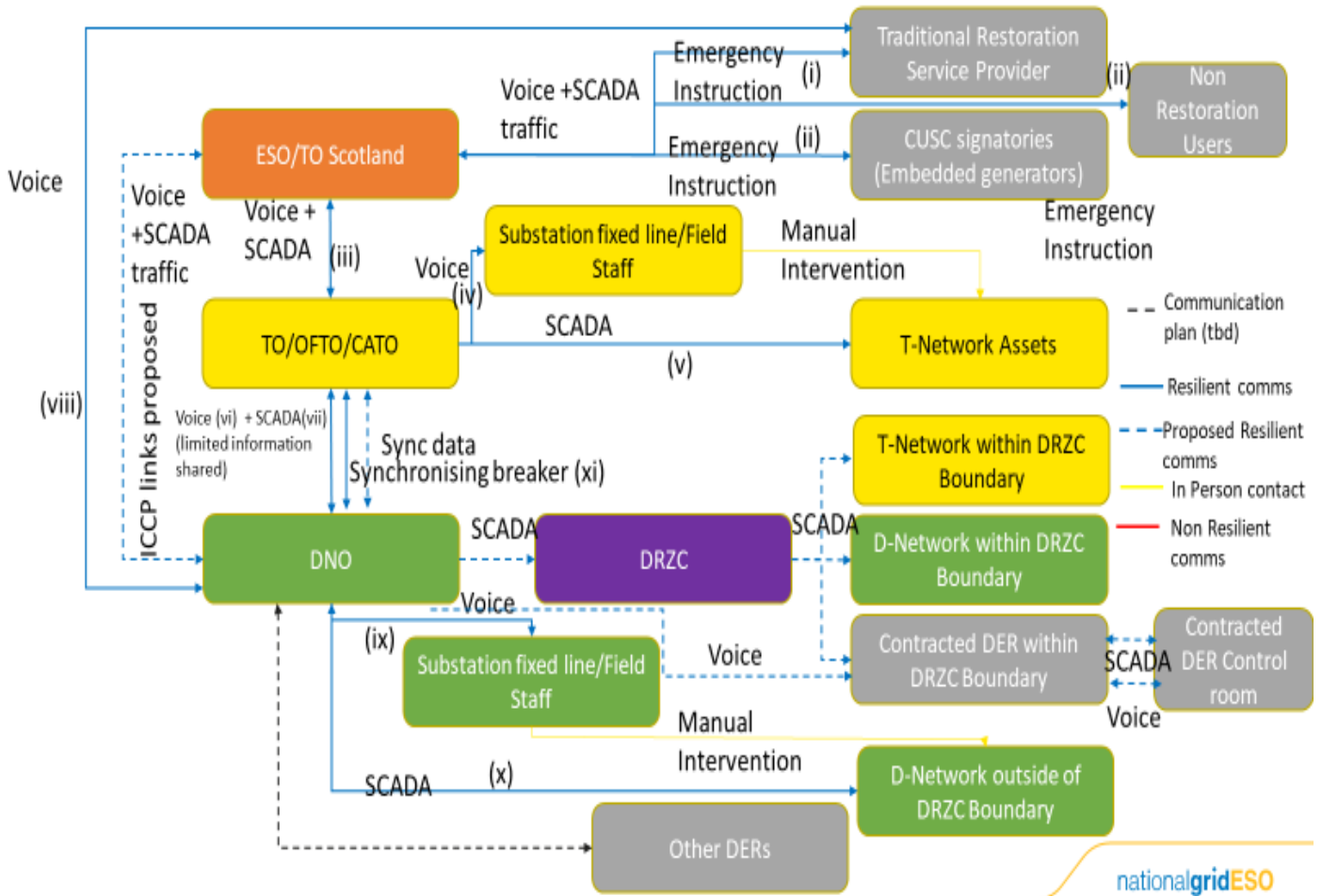

Figure 3: Proposed Transmission and Distribution Led Restoration communication map

An analysis of the interfaces required to implement the Distribution Restoration Zone Controller (DRZC) was also carried out. It became apparent that some of these would be determined during implementation by the suppliers and the subgroup do not yet have the necessary insight of the workings of the DRZC to articulate this. The subgroup also listed possible requirements that need to be defined and documented as part of delivering the DRZC. These parameters include bandwidth, protocol etc.

The group discussed the following options:

- That DNOs might collectively agree to develop standard parameters in the future when a small number of DRZCs have been implemented.
- Noting that the parameters may vary from one DNO to another DNO, DRZC implementation, is likely to vary from one DNO to another and be influenced by which DRZC supplier a DNO chooses. This implies that the detailed specification (as opposed to the functional specification) of DRZCs should not be standardised.

These options were escalated to the main GC0156 workgroup, and it was agreed that the two options should be included in the consultation.

- Scope the requirements by inviting vendors who specialise in DRZC implementation to agree a standard
- or wait until they have deployed 1 or 2 DRZCs where they would have garnered enough information to specify the requirements. It would however be advantageous to involve DRZC vendors in the process.

It was also suggested that the DNOs could use the ENA Strategic Telecoms group as the umbrella body to coordinate this process.



Table 3 below listed the DRZC communication interfaces details.



A-End	B-End	Name / ident	Protocol	Medium	Bandwidth	Latency	Encryption	Physical interface	Comments
Local Controller (LC)	RTU / DER Control interface (R1)	LC R1	TBC	Copper / fibre	TBC	TBC	TBC	TBC	This will be a hard-wired cable running between the local controller and RTU. The technical specifications of the medium will be finalised once the system parameters have been defined by the control system design authority.
Local Controller (LC)	Distributed Controller (DC)	LCA DC	TBC	fibre	TBC	TBC	TBC	TBC	This will be a circuit carrying data between the local controller and distributed zone controller. It can be made up of several hops, but the end-to-end characteristics shall be such to meet the specified technical system requirements once defined by the control system design authority.
Distributed Controller (DC)	Central Controller (CC)	DC CC	TBC	fibre	TBC	TBC	TBC	TBC	This will be a circuit carrying data between the Distributed Zone controller and the central controller of the DNO. It can be made up of several hops, but the end-to-end characteristics shall be such to meet the specified technical system requirements once defined by the control system design authority.

A-End	B-End	Name / ident	Protocol	Medium	Bandwidth	Latency	Encryption	Physical interface	Comments
Central Controller (CC)	DNO DMS (DD)	CC DD	TBC	Copper / fibre  Layer 1	TBC	TBC	TBC	TBC	This will be a hard-wired connection between the central controller and local DNO DMS system. It is anticipated this will be co-located within the DNO control centre and will be defined by the control system design authority.
DNO DMS (DD)	ESO DMS (ED)	DD ED (ICCP)	ICCP	OpTel Fibre	TBC	TBC	TBC	TBC	This will be a circuit carrying data between the DNO DMS System and ESO control centre. The function is to provide the ESO with visibility of the DNO network. The circuit can be made up of several hops, but the end-to-end characteristics shall be such as defined by the control system design authority.

Table 3: Distribution Restoration Zone Controller Interface

## ESO – DNO Interface

The subgroup reviewed the communication interface between the ESO and the DNOs.

The standard interface currently used for exchange of real time data between the energy management system is the Inter-Control Centre Communication Protocol (ICCP). Some of the ICCPs links are already connected and some are in development.

The ICCP link or equivalent will be required to be connected to all the DNOs licensed areas (14). The ESO's preferred method is to provide dual links, one link to the main control centre and the other to the backup control centre of each of the 6 DNOs companies, with each DNO providing all the necessary interconnection within their respective Licence Area(s). However, where it is impractical to connect the interlink within the DNO company, the ESO will connect dual ICCP links or equivalent directly to the respective DNO licensed areas.

The diagram below captures the current state of the ICCP links between the ESO and DNOs.

It should be noted that another type of link called a PI link exists between the ESO and SSEN in Scotland.

It is understood that the PI links would need to be replaced by ICCP links as they are not as reliable as ICCP links, and they do not have a control functionality similar to that of an ICCP link.

The DNO representatives in the group provided contacts within their company that the ESO will follow up when implementing the ICCP links.

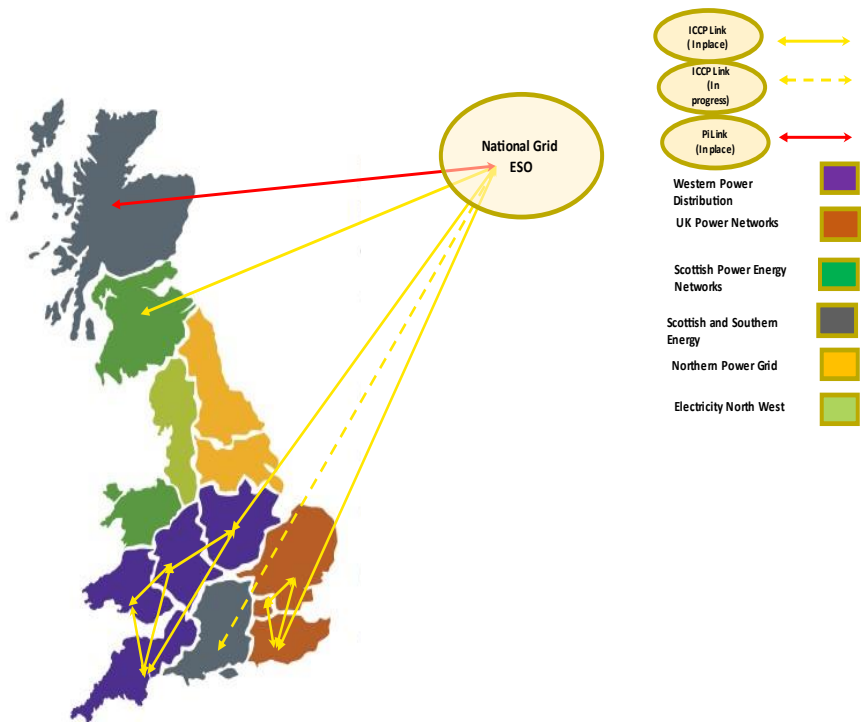

Figure 4: Current state of ICCP/PI interface between ESO and DNOs

## Proposals based on chapter 2

### Proposal 1

The subgroup considered other means of communicating with the field staff during restoration events where there is non-resilient communication. The proposal below, if adopted, should be documented as part of the restoration process by the respective organisations.

- Develop a mobilisation plan to get the field staff in the event of a shutdown to where there is a resilient communication.

### Proposal 2

As regards DRZC development, DNOs could use the ENA Strategic Telecoms group as the umbrella body to coordinate the process to:

- Scope the requirements by inviting vendors who specialise in DRZC implementation to agree a standard
- or wait until DNOs have deployed 1 or 2 DRZCs where they would have garnered enough information to specify the requirements. It would however be advantageous to involve DRZC vendors in the process.

**Disagreements**

None

**Legal Text References**

Telephony- CC\ECC 6.5.5; DPC6.7.4

Distribution restoration zone control system CC\ ECC 6.4.6.3 Including the requirements for ICCP link

Functional specification CC\ECC 7.10.3

Cyber security CC\ECC 7.10.5; DPC6.8.4

Relevant electrical standards - control telephony standard, communication standard and the high-level functional requirements of the Distribution Restoration Zone Control System listed as Electrical Standards in the Annex to the General Conditions.

**Alternatives**

None

### 3) DNO – DER Telecommunication Interface

The subgroup reviewed three different cases to establish telecoms infrastructure ownership when providing communication from the DNOs to the DERs. It was noted that the provision of communication links is business as normal for all parties.

It was recognised that there could be variations of these 3 cases.

In general, the DNO and DER would agree on the ownership structure that applies depending on this being an existing or new site.

Few cases were highlighted for new sites and existing sites:

- In a new site build where the DER is installing the power cable(s) to the connection point with the DNO, it would be ideal for the DER to provide the communication cable at the time. The cost recovery mechanism should be as agreed in the Market and Funding Mechanism subgroup.
- In areas where a party has a suitable wayleave agreement in place, it will be ideal for the party to arrange the communication infrastructure, however payment for the services will follow the agreed funding mechanism.

The 3 cases identified are the following and this is represented in Figures 5,6 and 7

- DNO-DER ownership boundary co-located in DNO/DER property
- DNO-DER ownership boundary located in DER property
- DNO-DER ownership boundary located in DNO property

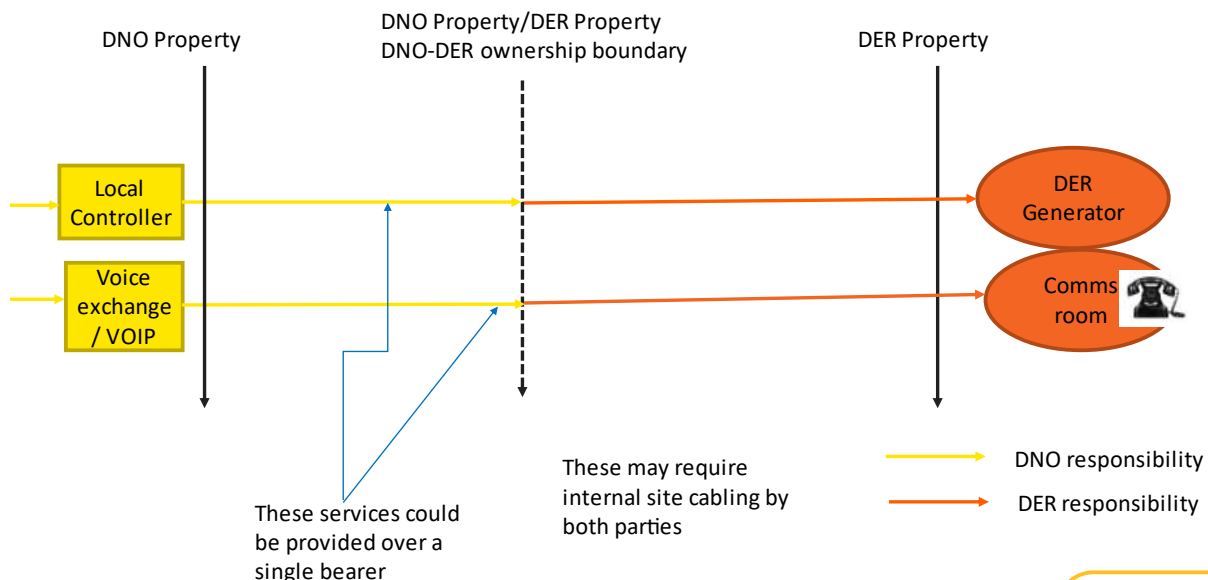

Figure 5: DNO-DER ownership boundary co-located in DNO/DER property

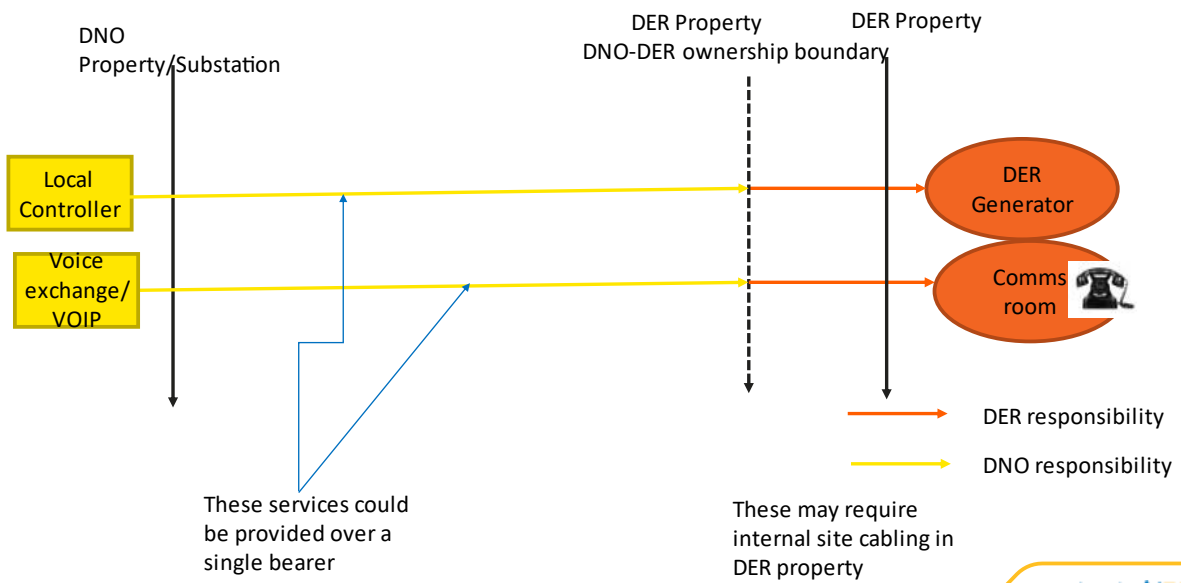

Figure 6: DNO-DER ownership boundary located in DER property

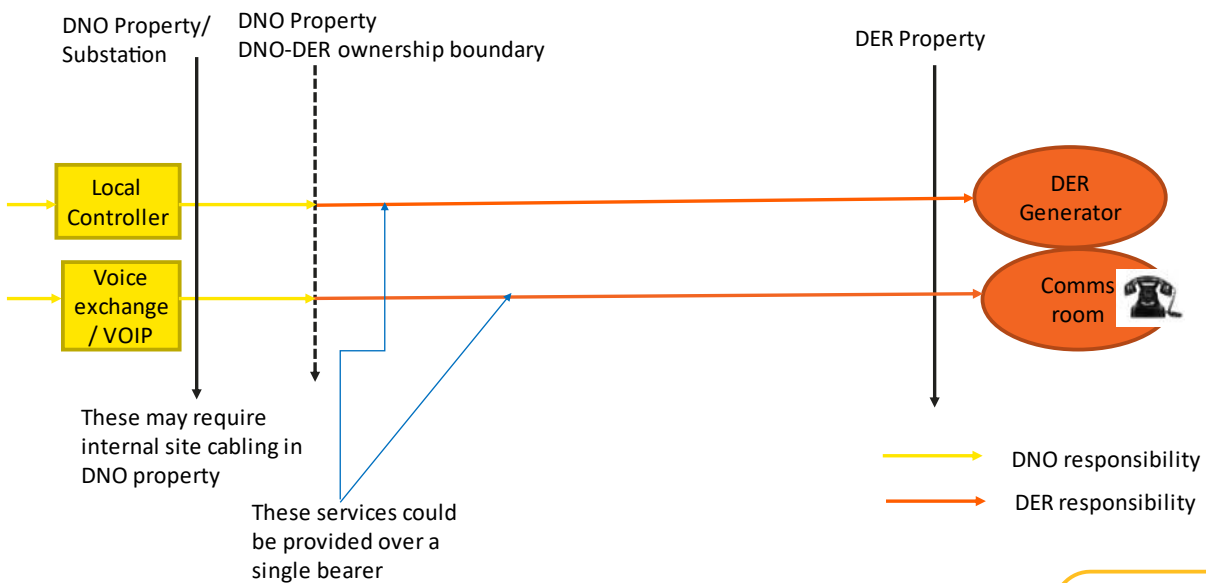

Figure 7: DNO-DER ownership boundary located in DNO property

**Proposal**

The DNOs and DER would agree on the ownership structure that applies taking into considerations the special circumstances noted above

In general, for a DRZ, it will be appropriate to have only a single communication path to the Restoration Service Providers site/assets. In some cases, there is an elevated risk of interrupted communication, or a specific business as usual (as opposed to Restoration Service) needs, a second separate path might be appropriate, but the number of separate communication paths should never outnumber the number of independent electrical circuits connecting the site/assets to the wider network.

**Disagreements**

None

**Legal Text**

Specific obligation related to ownership boundaries is specified in connection agreements.

**Alternatives**

None



## 4) Communication option for DERs with non-resilient communication providers

It was acknowledged that it would not be cost justifiable to provide 72-hour independent power resilient communication infrastructure from DNOs to all DERs. The requirement is to provide the resilient communication to the contracted providers – Anchor and Top up service providers. However, the subgroup reviewed the options available to the DERs with non-resilient communications during the restoration process. The reviewed proposal consists of 3 options listed below:

### Option 1: Synchronise automatically once the power system is restored

- This option is available to other users who do not have resilient communication infrastructure and could not communicate with the DNOs when the site has been energised.
- Small capacity generators (up to 50 MW) may use this approach already as part of business-as-usual activity and do not have an obligation to inform the DNO before connecting.
- It is advised that as part of creating a Distribution Restoration Zone Plan, the total capacities and location of such generators should be captured so that the DRZC can be sized and structured to cater for the effect of the generators connecting automatically.
- **Option 2: Hold off synchronisation until communication network is restored** This option is available to other users who do not have resilient communication infrastructure and cannot communicate with the DNOs when the site has been energised.
- Generators whose operation due to safety considerations would require communication with the DNOs to facilitate synchronisation will fall into this category.
- They would hold off synchronising to the network even when their sites are energised until communication with the DNO is restored.
- These classes of generators/providers who fall under this category would be captured in the DNO licensed area plan as part of the design of the Distribution Restoration Zone.

### Discounted option:

The group discussed the option below and agreed to discount it based on the feedback that it will be complicated to implement because DERs will not be able to distinguish between a local fault or system shutdown.

### Option 3: Use pre-agreed network condition and switching instruction

- A documented switching sequence and steps are used to synchronise with the electricity system without the need for voice communication between other users and the DNO.
- Both parties would agree the network conditions to be met, the switching sequence and other actions which would be documented and agreed.
- This situation may arise where a DER has already energised another User's site, but the communication network is yet to be restored.

## 5) Functional Specifications

### 5.1 Framework for Functional specifications

#### Proposal

The ESO proposed that the voice and data functional requirements document should be a standard document which is referenced to the Grid/Distribution Code similar to the Control Telephony Electrical Standard.

#### Disagreements

None

#### Legal Text References

Telephony- CC\ECC 6.5.5; DPC6.7.4

Distribution restoration zone control system CC\ ECC 6.4.6.3 Including the requirements for ICCP link Functional specification CC\ECC 7.10.3

Cyber security CC\ECC 7.10.5; DPC6.8.4

Relevant electrical standard - control telephony standard, communication standard and high level specification for distribution restoration zone control system, covered in annexed to the general condition

#### Alternatives

None

### 5.2 Functional specifications

The telecommunication systems are in place to facilitate fundamentally 3 use cases which are used in both the day-to-day operation of the electricity network and, in the event of a wide area power network failure, the recovery of the electricity network. These systems are:

- 1 Protection
- 2 SCADA
- 3 Voice

The technical specification of the circuits required for protection will remain unchanged throughout the entire network. Details are specified in the most recent version of the ENA Technical Specification 48-6-7.

The technical specification of the power resilience of the circuits required for SCADA communication will remain unchanged; ENA Technical Specification G91 has all the requirements.

EC-RRG Resilience Guidelines for Providers of Critical National Telecommunications Infrastructure provides advice and guidance on agreed best practice in the establishment and maintenance of resilience within telecommunications networks and services, for those Communications Providers which are part of the UK's Critical National Infrastructure (CNI), either because of the scale of their operations or because they provide key services to other parts of the CNI.

Voice communication between the ESO, TO, DNO and transmission connected generators use a private telephony system which is owned by Transmission Licensees and used by both the ESO and Transmission Licensees. This system is known as control telephony and the technical specification of this system is contained in the Grid Code Relevant Electrical Standard “Control Telephony Technical Standard”, which is currently being revised in Grid Code modification GC0148 “EU Restoration Standard.” It is recognised that the ownership and provision of these services could change fundamentally, however it is important these services meet the functional specifications required to restore the electricity system.

In order to extend the restoration to include embedded generation there is a need to define the technical specification for additional communication interfaces that will form part and facilitate the electricity system recovery system.

These have been identified as:

- 1 ICCP Link or equivalent
- 2 Balancing or Distributed Restoration Zone Controller functionality
- 3 Voice

Inter-Control Centre Communications protocol (ICCP) links will provide real time situational awareness of the specific DNO electricity network to the ESO control room. This will enable the ESO to provide overall coordination of the restoration process. The ICCP link will connect the DNO’s network management system to the ESO’s energy management systems. These systems are usually within the control centres. The design and functional specification of the ICCP link will fall under the ESO to provide in coordination with the specific DNO.

The diagram below illustrates the components and communication interfaces of the DRZC.

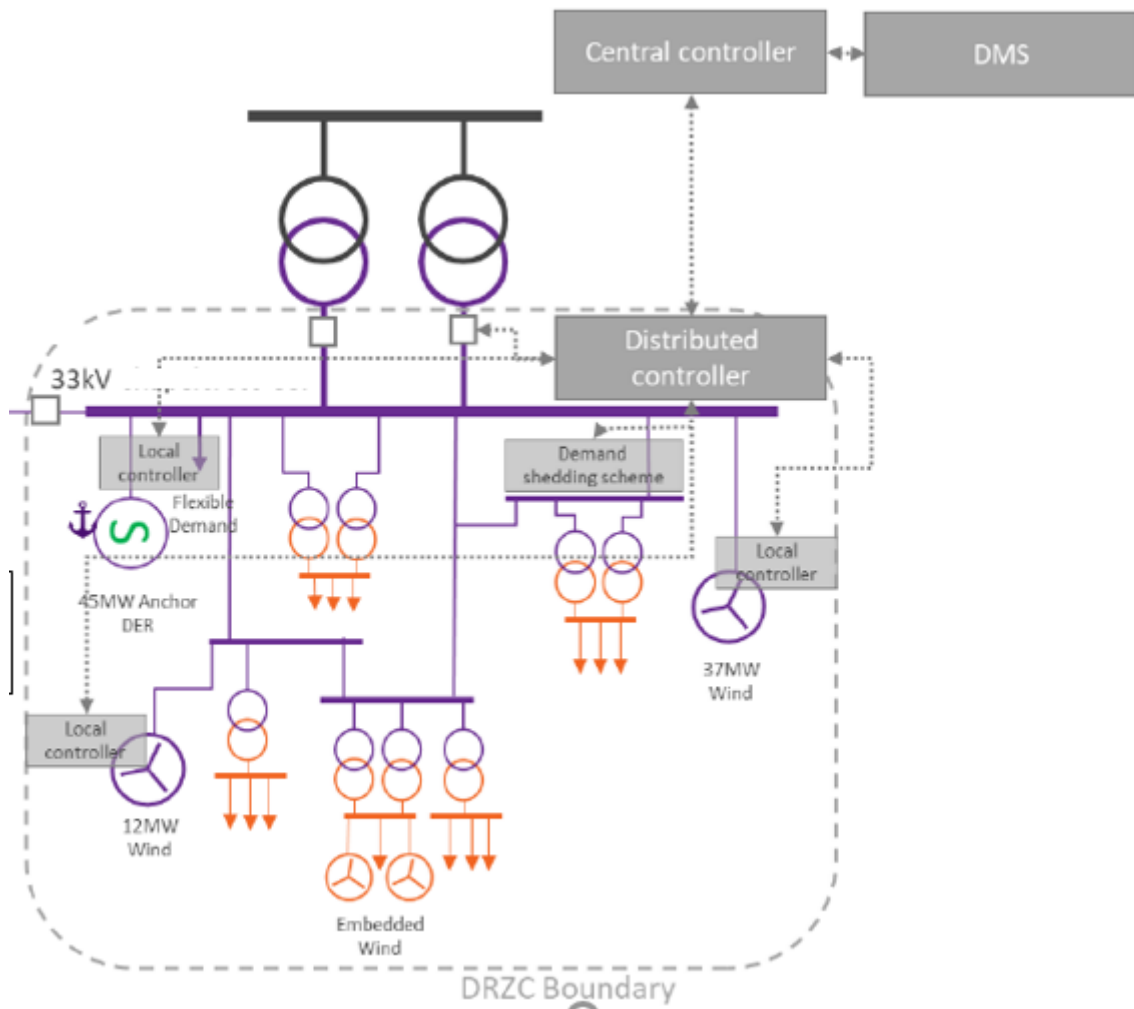

Figure 8: DRZC Schematics

There is a requirement for a new interface between the DRZC and the Remote Terminal Unit (RTU) of both the anchor generators and top up service providers as well as from the distributed controller to the central controller. The DRZC will comprise a central controller and one or more distributed local controllers. The interface from the local controller to the DER will need to be defined on a case by case basis.

There is a requirement for power resilient voice communication systems to the contracted parties during the restoration event.

Figure 2 shows the distributed restoration communication map.

### Technical specification

The following specifications will be determined when deploying the Distributed Restoration Zone Controller (DRZC). It was acknowledged that this could vary depending on the specific implementation of the DRZC as the DNOs will be individually implementing it.

### Balancing

1. Latency

The end-to-end communication paths.

2. Resilience

Any circuits within an IP network shall be configured for the highest level of guaranteed quality of service.

3. Bandwidth

bandwidth required for end-to-end traffic management.

4. Protocol support

List of protocols supported for the end-to-end deployment of the DRZC

5. Circuit path separation / redundancy

In general, it will be appropriate to have only a single communication path to the Restoration Service Providers site/assets. In some cases, there is an elevated risk of interrupted communication, or a specific business as usual (as opposed to Restoration Service) needs, a second separate path might be appropriate, but the number of separate communication paths should never outnumber the number of independent electrical circuits connecting the site/assets to the wider network

6. Support and maintenance arrangement

The DNO will be responsible for the installation and ongoing maintenance of this communication path.

7. Cyber security

The DNO shall be responsible for ensuring the data is secure and meeting legal and Network and Information Security (NIS) Directive requirements.

8. Physical security

- a. The DNO will be responsible for installing the communications path up to the RTU and the cable(s) shall be suitably protected against physical harm.
- b. The DER shall be responsible for ensuring the cable(s) is suitably protected within their equipment.

9. Power resilience

- a. The circuit will have the minimum power resilience end to end as required in EREC G91.
- b. The DNO will have responsibility for ensuring the design meets the criteria.
- c. The DER owner shall be responsible for ensuring and demonstrating equivalent power resilience on all the equipment necessary to operate the DER in accordance with the DRZP.

10. Testing /Assurance

- a. The DNO shall be responsible for testing the communications path as specified in the Assurance process.
- b. The DER owner shall provide technical support in the event of a fault situation.

**Voice**

- 1 Solution

- a. The DNO shall be responsible for the installation of a voice communication facility at or near the DNO’s RTU at the generator’s site.
- b. If the generator wishes to install the phone at any other location it may be possible at the DNO’s discretion but the responsibility for the installation and power resilience on the generator site shall fall on the Restoration Service Provider. The Site Responsibility Schedule will provide guidance.

The following standards are recommended to be adhered to in providing and maintaining the telecommunication infrastructure and systems:

<b>Standard</b>	<b>Description</b>
<b>ITU-T G Series</b>	International Telecommunication Union standard where applicable.
<b>BS EN 61850</b>	Communication networks and systems for power utility automation.
<b>IEC 62351</b>	The IEC 62351 series of standards include cyber security technologies for some communication protocols specifically: IEC 60870-5 protocols (including IEEE 1815 (DNP3) as a derivative standard), IEC 60870-6 (ICCP). IEC 61850 protocols (including client-server, GOOSE, and sample values). IEC 61970 and IEC 61968 (Common Information Model – CIM).
<b>IEC 62443</b>	Requirements and processes for implementing and maintaining electronically secure industrial automation and control systems (IACS).

**Disagreements**

None

**Legal Text References**

Protection - CC\ECC 6.2.2.2, CC\ECC 6.2.3.7; DP6.8.5

Control – CC\ECC 6.2.2.7.1, CC\ECC 6.2.3.8.2; DPC6.8.6

SCADA – CC\ECC 6.5.6, TS.3.24.100; DP6.7

Voice – CC\ECC 6.5.5 control telephony standard and communication standard; DPC6.7.4

Distribution restoration zone control system CC\ ECC 6.4.6.3 Including the requirements for ICCP link

**Alternatives**

None

## 6) Cost/Timeline to deliver action plan/discussion

### Proposal

The group agreed that the cost and timeline to deliver the telecommunication infrastructure could not be ascertained at this time therefore the costs and timeline should be left to be developed at a later time by the relevant parties when they have enough information to do so.

### Disagreements

None