

## Stage 03: Modification Report

National Electricity Transmission System Security and Quality of Supply Standards (NETS SQSS)

# GSR014: Review of Requirement of Onshore Connection Facilities for Offshore Wind Farm Connections

What stage is this document at?

01 Work-Group Report

02 Industry Consultation

03 Modification Report

This Modification Report seeks to modify NETS SQSS Section 7.13.1.1: Onshore Connection Facilities: AC Circuits.

The purpose of this document is to assist the Authority in its decision of whether to implement the proposed modification to the NETS SQSS.

**Published on:** 04 February 2015



***The NETS SQSS Review Panel recommends:***

That GSR014 should be implemented as it better facilitates the applicable NETS SQSS objectives.



***High Impact:***

None.



***Medium Impact:***

None.



***Low Impact:***

Onshore TOs, OFTOs and OTSDUW parties.

## Contents



1	Executive Summary .....	3
2	Why Change? .....	5
3	Solution .....	6
4	Consultation .....	7
5	Impact & Assessment .....	12
	Annex 1 - Proposed Legal Text .....	14
	Annex 2 - Consultation Responses.....	15
	Annex 3 - Additional Sensitivity Analysis Results.....	32

### Any Questions?

Contact:

**Nick Martin**

Code Administrator



[nick.martin@nationalgrid.com](mailto:nick.martin@nationalgrid.com)



01926 654757

Proposer:

**Mike Lee**

Transmission  
Investment LLP



[mike.lee@transmissioninvestment.com](mailto:mike.lee@transmissioninvestment.com)



0203 668 6688

## About this Document

This Modification Report contains the information the NETS SQSS Review Panel believes is required for the Authority to progress a change to the National Electricity Transmission System Security and Quality of Supply Standards (NETS SQSS).

## Document Control

Version	Date	Author	Change Reference
1.0	04 / 06 / 2014	National Grid	Draft Industry Consultation
1.1	30 / 07 / 2014	National Grid	Final Industry Consultation
1.2	04 / 09 / 2014	National Grid	Amended to clarify scope as AC only connections. Final Industry Consultation
1.4	27 / 11 / 2014	National Grid	Initial Draft of Modification Report to Authority including Industry Consultation Responses
1.5	30 / 11 / 2014	National Grid	Further Draft of Modification Report to Authority for Review by NETS SQSS Review Panel
2.0	04 / 02 / 2015	National Grid	Report to Authority

GSR014 Modification  
Report

Date 04/02/2015

Version 2.0

Page 2 of 42

## 1 Executive Summary

- 1.1 The GSR014 Working-Group has conducted a cost benefit analysis (CBA)<sup>1</sup> using the Spackman<sup>2</sup> approach to determine the optimum design of offshore transmission connections to onshore electricity networks for AC connected offshore generation. Specifically, the CBA considered whether two HV switch-bays (Figure 1 Design 1) or one HV switch-bay (Figure 1 Design 2) should be installed where the offshore wind farm connects to the onshore transmission network.
- 1.2 For the purpose of this analysis it was assumed that the onshore elements for the connection of the offshore transmission system, for which schematic diagrams are presented in Figure 1 below, would operate at 400kV. Furthermore, such systems shall comprise of underground cables, circuit breakers, disconnectors, transformers and the onshore substation that connects the offshore system to the onshore system.

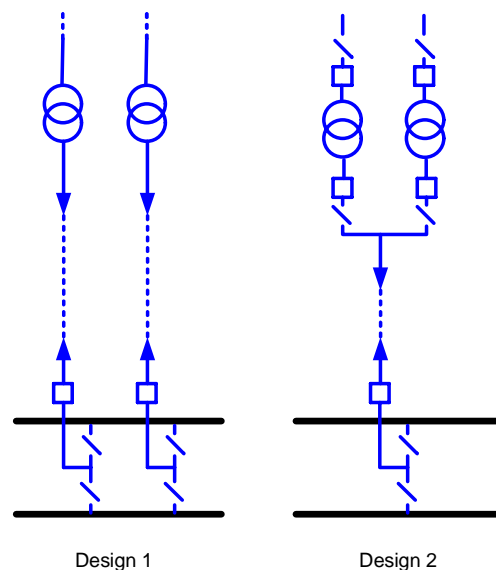

Figure 1. Schematic diagram of the offshore transmission system designs considered.

- 1.3 A balancing exercise between the following two broad categories of costs was conducted to determine the optimal network design:
- The cost of offshore transmission system investment that comprises of:
    - The cost of underground cables
    - The cost of transformers
    - The cost of onshore switchgear
  - The capitalised cost of the expected curtailed energy due to preventative and corrective maintenance over the period of the asset life.
- 1.4 Note that costs that are common to both one switch-bay and two switch-bay designs were not included within the CBA. These common costs were assumed to include the capital costs of offshore switchgear and of reactive compensation and filter equipment.

<sup>1</sup> The basic principles of Cost Benefit Analysis (CBA) used in the presented work are based on conclusions and recommendations on CBA as approved and published by Ofgem at the following link:

<https://www.ofgem.gov.uk/ofgem-publications/51759/security-recommendations.pdf>

<sup>2</sup> The Spackman approach is the most appropriate method for CBAs in cases where a firm finances the investment but benefits mainly accrue to consumers and / or the wider public. The Spackman method was published by the Joint Regulators Group (JRG), 25 July 2012.

- 1.5 Based upon evaluation of these two primary cost components for the two offshore transmission system configurations considered, the Working-Group has identified optimal designs for a range of wind farms with capacities of 250MW, 500MW and 1000MW and has included sensitivities around the onshore cable length. Following industry consultation, additional sensitivities have been considered for wind farm capacity and onshore cable length.
- 1.6 The CBA calculated the cost benefit over the assumed twenty year life of the wind farm assuming a pre-tax weighted average cost of capital (WACC) of 6.25%, an interest during construction (IDC) rate of 6.25% and a social time preference rate (STPR) of 3.5%. The working-group also conducted a sensitivity analysis using a range of WACC (7.9% and 8.9%) to confirm that the conclusions of the report remain unchanged.
- 1.7 The energy costs used in the CBA were assumed to be £150/MWh, which is equal to two ROCs plus the energy price. This value also coincides with the strike price under EMR for offshore wind farms with connections dates pre-2017. This price shall be reduced to £135/MWh for wind farms connecting post-2017. However, this change in energy price does not have a material impact on the overall conclusions of this report. Following industry consultation, a sensitivity to test the conclusions against lower values of curtailed energy costs has been included. This is based on £50/MWh.
- 1.8 The Spackman approach was used to compare the costs and benefits between Design 1 and Design 2, both shown in Figure 1 above.
  - The capital costs used were the transmission investment costs of each design. The transmission capital costs were converted into an annual cost using the IDC value of 7.9%. This produces a stream of financing costs or an appropriate time profile of annualised costs.
  - The benefits used were the avoided curtailment costs which were calculated for each design and included for each year. The STPR of 3.5% was then applied in discounting these costs, as recommended by HM Treasury Green Book.
- 1.9 The results show that using the Spackman approach, Design 1 gives a higher NPV benefit compared to Design 2 when tested over a range of generation capacities for both AIS and GIS switchgear designs.
- 1.10 Based upon these results as presented in the Working-Group Report, and the additional sensitivities completed following the industry consultation, it is proposed that a number of changes are implemented to NETS SQSS Section 7.13.1.1. The legal text required to implement these proposals is provided within Annex 1 of this document. These changes would apply where there is AC transformation to the onshore transmission network and not where there are DC connection and conversion facilities. To further clarify this distinction between AC and DC connections, it is proposed to change the headings of Section 7.13.1 and Section 7.13.2 also. Again, these proposals are provided within Annex 1 of this document.

## 2 Why Change?

- 2.1 The National Electricity Transmission System Security and Quality of Supply Standards (NETS SQSS) provides a coordinated set of criteria and methodologies that transmission licensees are required to use in the planning, development and operation of the National Electricity Transmission System (NETS).
- 2.2 The NETS SQSS was originally developed across 1990 to 2005 for application to the onshore transmission system in England, Wales and Scotland. In June 2009, additional criteria, namely NETS SQSS Sections 7, 8, 9 and 10 were introduced for offshore transmission systems.
- 2.3 During the June 2009 revision, an issue was raised by National Grid as the Transmission Owner (TO) to revisit the wording of Section 7.13.1.1 that currently reads as:

*In the case of offshore power park module only connections, and where the offshore grid entry point capacity is 120MW or more, following a planned outage or a fault outage of a single AC offshore transformer circuit at the onshore AC transformation facilities, the loss of power infeed shall not exceed the smaller of either: 50% of the offshore grid entry point capacity; or the full normal infeed loss risk.*
- 2.4 This current wording commonly results in onshore designs to connect an offshore wind farm having two transformers, each rated at 50% of the offshore grid entry point capacity, and two high voltage bays at the onshore TO substation.
- 2.5 It is believed that the work undertaken in developing the offshore NETS SQSS criteria was not conclusive on the need for two bays to connect an offshore wind farm to the onshore transmission system. In practice, in some cases where two transformers have been used, these have been connected to separate switch-bays, and in some cases they have been banked onto a single switch-bay at the onshore transmission substation.
- 2.6 The purpose of Section 7.13.1.1 is to ensure that in the event of a permanent fault on a transformer, the wind farm would not be completely disconnected from the transmission system for the duration of the transformer replacement time, which could be up to 18 months. The same principle can also be applied to the switch-bays at the onshore transmission substation and the connections to these switch-bays.
- 2.7 Therefore the aim of this study was to investigate whether the NETS SQSS criteria should be clarified in respect of the number of high voltage switch-bays. Where there are two transformers, should two HV cables and two high voltage substation bays be provided? Or would two transformers connected to a cable and a single bay be sufficient?
- 2.8 The GSR014 Working-Group investigation didn't show that the single bay option was economic. In fact, there was a firm cost benefit case for Design 1 (i.e. two bays). The proposed change to the NETS SQSS will make the use of Design 1 clearer. In practice the majority of offshore designs have adopted this two bay approach already. The proposed NETS SQSS changes will formalise the position.

### 3 Solution

- 3.1 The detailed results from the CBA using the Spackman approach and the calculations of constraint costs are as contained in the Working-Group Report. Over the range of sensitivities considered, the NPV of the benefit of Design 1 compared to Design 2 ranged between £6m and £37m.
- 3.2 Additional sensitivities were carried out following a wider consultation on the GSR014 Working-Group Report. These are further discussed in Section 4 below. These sensitivities consider lower curtailment costs, longer cable lengths and reduced grid entry point capacities. All of these sensitivities continue to show a positive NPV for Design 1 compared to Design 2.
- 3.3 Based upon these results it is proposed that a number of changes are made to NETS SQSS Section 7.13.1.1. The legal text required to implement these proposals is provided within Annex 1 of this document. In addition, to emphasise that these proposals shall only apply to AC connections, it is proposed to change the headings of Section 7.13.1 and Section 7.13.2 also. Again, these proposals are provided within Annex 1 of this document.

## 4 Consultation

4.1 The GSR014 consultation was published on 13th October 2014. Responses were invited upon the proposals outlined in the consultation with a closing date of 14th November 2014.

4.2 Responses were invited to the following questions:

- (i) The proposal is underpinned by economic analysis of two designs for a range of scenarios. Has the analysis considered a wide enough range of scenarios and designs to reach a generic conclusion? Are the costs (capital and operational) and availability data used in the analysis reasonable?
- (ii) The proposed modification is not intended to apply retrospectively to connections completed before 31<sup>st</sup> December 2014 and it is proposed that this qualifying date be introduced. Are you in agreement with this approach and date?
- (iii) Do you agree with a proposed effective date of 1<sup>st</sup> January 2015 for these changes to come into effect?
- (iv) The Working-Group report indicates that there are circumstances when the cost benefit analysis may demonstrate that a single bay option is economic for future connections. For example where an existing substation is not able to be extended, or requires uneconomic and extensive civil works. In these cases, the proposed modification will require that a lifetime derogation is required. Is this a reasonable requirement against the benefits of the proposal?
- (v) What additional clarity or other benefits does the proposal bring to the criteria of the NETS SQSS?
- (vi) Do you support the proposed implementation approach of 10 business days following an Authority decision?

4.3 Responses were received from five parties: Blue Transmission, DONG Energy, Scottish Power Renewables, Statkraft and National Grid Electricity Transmission. Their response proformas are included within Annex 2 of this document. The responses varied in their support of GSR014. One respondent supported the change provided it was not applied retrospectively to existing connections. The 4 other respondents did not support the change and identified a number of points for further consideration.

4.4 The main points raised are summarised below:

- (i) Several respondents stated that they would prefer that a standard requirement for 2 switch-bays was not included in the NETS SQSS. They would prefer a cost benefit assessment be carried out on each design.
- (ii) Several respondents were concerned as to whether the cost benefit analysis had been sufficiently broad. Additional cases were identified including generation entry capacities below 250MW, longer cable lengths and the connection to 275kV substations.
- (iii) One respondent was concerned as to whether other equipment such as reactive compensation should be factored into the assessment.

- (iv) One respondent was concerned that the costs assumed for curtailed energy were incorrect as constraint payments or ROC's would not be paid to offshore generation.
- (v) One respondent was concerned that the capital costs of a two switch-bay connection could be much higher than assumed in the analysis.
- (vi) One respondent suggested a potentially less expensive design option based on disconnectors.
- (vii) Several respondents agreed that, if implemented, the change should not be made retrospective. However, there were concerns expressed about the qualification requirements for the change not being applied to a particular project.
- (viii) Several respondents were against the requirement for derogation in the event of a single switch-bay option being pursued. Two respondents were also concerned about the project risks that the requirement for derogation would introduce.
- (ix) Several respondents felt that the wording of the NETS SQSS change should be clearer.

4.5 These main points are dealt with in the following paragraphs. Other specific points that were raised on the need to clarify information on WACC values and the assumptions in respect of transformer replacement timescales have been dealt with elsewhere in this report.

#### **Standard Connection vs. Cost Benefit Assessment on a Case by Case Basis**

4.6 The workgroup assessment has demonstrated that where there are 2 transformers, it is economic to have 2 switch-bays except in exceptional circumstances. Making 2 switch-bays as the standard connection is clearer than the current position and does not preclude other connections if these are shown to be cost-beneficial. (However, if it was decided to bank 2 transformers onto a single switch-bay, this would require derogation.)

4.7 NETS SQSS 7.21 allows a customer to request a variation to connection design against paragraphs 7.7 to 7.19 which includes this particular 7.13.1. Hence a customer can opt for a lower standard of connection design. Some Workgroup members were keen to allow the option of the connected party being able to request a lower standard of connection (via a design variation) but they also wanted TOs to follow the formal derogation process to provide transparency in the case where there is disagreement between the TO and a customer. In the case where the customer is supportive then this would be covered by the design variation provisions.

#### **Additional Sensitivity Analysis - Cable Length and Generation Capacity**

4.8 The working-group has carried out additional analysis to investigate the effects of a significantly longer cable length of 700m.

4.9 It was found that significantly longer cable lengths do impact upon the overall results of the volume of wind energy curtailed and its associated costs. This can be seen in Table 1 below. More complete and detailed results tables can be found in Annex 3 of this Modification Report. The results do not affect the conclusions of the working-group and a two bay configuration remains the most economic and efficient solution to connect an offshore wind farm.



4.10 These results also include an offshore wind farm of 120MW capacity. It can be seen that the results for the GIS substation show a small benefit for Design 1 (two bays) in comparison to Design 2 (one bay).

Wind Farm Capacity (MW)	Cable Length (m)			
	50m		700m	
	Design 1	Design 2	Design 1	Design 2
120MW	AIS	£4.74m	AIS	£3.85m
	GIS	£6.58m	GIS	£6.84m
250MW	Design 1	Design 2	Design 1	Design 2
	AIS	£6.47m	AIS	£5.59m
	GIS	£11.13m	GIS	£9.48m
500MW	Design 1	Design 2	Design 1	Design 2
	AIS	£13.27m	AIS	£12.38m
	GIS	£18.87m	GIS	£17.23m
1000MW	Design 1	Design 2	Design 1	Design 2
	AIS	£20.37m	AIS	£19.49m
	GIS	£36.64m	GIS	£34.99m

Table 1. CBA Results for Different Cable Lengths and for further 120MW Case  
(Results show NPV of Design 1 v Design 2)

### The Impact of Different Voltage Levels on the Assessment

4.11 The capital costs for 275kV substations will be similar to or below the costs of 400kV substations. Therefore the main conclusions from the cost benefit analysis will apply to 275kV onshore connection facilities also.

4.12 Typically, the connection of an offshore wind farm at 132kV would not be considered an economical solution. However, even if 132kV was an option, the difference in capital costs between one or two switch-bays would be less than for 400kV or 275kV.

### The Inclusion of Other Equipment (Filters, Reactors...etc...)

4.13 Further concerns were raised with respect to the working-groups analysis not taking into consideration the additional equipment that could be installed within a substation bay (i.e. filters, reactors...etc...). This equipment would increase the capital cost to a similar extent for the one or two switch-bay options and will also not materially affect the availability of the wind farm or change the amount of wind farm energy curtailment. Therefore, inclusion of this additional equipment will not affect the final conclusions of the cost benefit analysis.

4.14 In addition, it is unlikely that an offshore wind farm shall be connected via overhead lines. This is the reason these were excluded from the analysis.

## Additional Sensitivity Analysis - Expected Cost of Curtailed Energy

4.15 The calculations employed by the working-group were based upon the methodology presented in the report: “Cost Benefit Methodology for Optimal Design of Offshore Transmission Systems”. The report specifies the cost value of a ROC to be £30/MWh and uses two additional values for replacement generation costs of £30/MWh and £35/MWh for summer and winter respectively. That earlier report therefore used a price variation between £50/MWh and £100/MWh for sensitivity analysis.

4.16 The GSR014 working-group base assumption for curtailed energy costs of £150/MWh updated the earlier assumption on the basis that offshore generation receives two ROCs and replacement generation cost are now estimated to be £50/MWh. Table 2 below shows that the overall conclusions of the working-group do not change as a result of ignoring the ROC’s and using a lower curtailment cost of £50/MWh. Design 1 remains more economic, although with a smaller benefit compared to the £150/MWh case.

Wind Farm Capacity (MW)	Energy Curtailment Costs (£/MWh)			
	£150/MWh		£50/MWh	
250MW	Design 1	Design 2	Design 1	Design 2
	AIS	£6.47m	AIS	£3.32m
	GIS	£11.13m	GIS	£6.79m
500MW	Design 1	Design 2	Design 1	Design 2
	AIS	£13.27m	AIS	£4.99m
	GIS	£18.87m	GIS	£8.09m
1000MW	Design 1	Design 2	Design 1	Design 2
	AIS	£20.37m	AIS	£7.83m
	GIS	£36.64m	GIS	£13.46m

Table 2. CBA Results for Different Energy Curtailment Costs  
(Results show NPV of Design 1 v Design 2)

4.17 More complete and detailed results tables can be found in Annex 3 of this Modification Report.

## The Impact of Higher Costs for a Two Switch-Bay Solution

4.18 If the capital costs of a two switch-bay connection were particularly high compared to a single switch-bay connection, due to the need for major extension of an existing substation for example, this could be demonstrated through a cost benefit assessment and a design variation or derogation could be sought.

## Alternative Solutions Utilising Disconnectors Rather Than Circuit Breakers

4.19 The workgroup considered disconnector based solutions but did not pursue these as they would lead to greater curtailment of generation capacity. For GIS substations, the cost differential between disconnector only and circuit breaker based solutions is also likely to be small.

## Qualification Requirements for Retrospectivity

- 4.20 It is not proposed that the requirement for two switch-bays be made retrospective to existing connections. The proposed qualification criteria in this respect was all existing single switch-bay connections and all proposed single switch-bay connections with a connection agreement in place on 31<sup>st</sup> December 2014. However, whilst this was included in the proposed legal text included in the Industry Consultation Report, the qualification criteria were not discussed in detail in the Industry Consultation Report.
- 4.21 Based on the arguments made by respondents in respect of having already firmed up a connection but not yet having a connection agreement finalised (perhaps through a planning application), it is proposed to extend the qualification date for having a connection agreement in place to 31<sup>st</sup> December 2015.

## Should Derogation be Required?

- 4.22 It is proposed that a derogation should be required if a TO chooses to install one switch-bay rather than two switch-bays. The risk to the development through the TO pursuing a derogation should be small and outweighed by the benefit of achieving a more cost-effective connection.

## Wording of Proposed NETS SQSS Change

- 4.23 The wording of the NETS SQSS change has been revised to improve clarity on the basis of the points made by respondents.

### NETS SQSS Working-Group Assessment

#### 5.1 National Grid

The NGET representatives (SO and TO) are supportive of this amendment.

#### 5.2 Offshore Transmission Owners (OFTOs)

The OFTO representative is supportive of this amendment. The proposed GSR014 amendment will have no impact on existing OFTO systems.

#### 5.3 Generators

The Generator representatives are supportive of this amendment.

#### 5.4 The Crown Estate

The Crown Estate representative is supportive of this amendment.

### NETS SQSS Review Panel Assessment

- 5.5 The NETS SQSS Review Panel members agreed that the proposed changes should be submitted to the Authority in the form of this Report to the Authority on 3rd December 2014.

### Impact on the NETS SQSS

- 5.6 GSR014 requires amendments to the following parts of the NETS SQSS:

- Section 7.13.1: AC Circuits.
- Section 7.13.1.1: Onshore Connection Facilities: AC Circuits.
- Section 7.13.2: DC Circuits.

- 5.7 The text required to give effect to these proposals is contained in Annex 1 of this Modification Report.

### Impact on the National Electricity Transmission System (NETS)

- 5.8 The proposed changes are expected to lead to reduced costs and more economic operation over the lifetime of the offshore transmission assets. In addition, the proposed changes are expected to increase the overall level of security of the National Electricity Transmission System. Furthermore, in the vast majority of all offshore designs to date, these have adopted the two bay approach already.

### Impact on NETS SQSS Users

- 5.9 There are four existing single bay connections that would not be compliant with the proposed revised requirements of Section 7.13.1.1. If the new requirement is made retrospective the impact could be quite significant on these NETS SQSS users. It is therefore proposed that the requirement is not made retrospective.

## Impact on Greenhouse Gas Emissions

5.10 The proposed modification will have no impact on Greenhouse Gas Emissions.

## Assessment Against NETS SQSS Objectives

5.11 The NETS SQSS Review Panel considers that the proposed changes would better facilitate the NETS SQSS objectives:

- (i) facilitate the planning, development and maintenance of an efficient, coordinated and economical system of electricity transmission, and the operation of that system in an efficient, economic and coordinated manner;

*The proposed changes are expected to lead to reduced costs and more economic operation over the lifetime of the offshore transmission assets.*

- (ii) ensure an appropriate level of security and quality of supply and safe operation of the National Electricity Transmission System;

*The proposed changes are expected to increase the overall level of security of the National Electricity Transmission System.*

- (iii) facilitate effective competition in the generation and supply of electricity, and (so far as consistent therewith) facilitating such competition in the distribution of electricity; and

*The proposal has a neutral impact on this objective.*

- (iv) facilitate electricity Transmission Licensees to comply with their obligations under EU law.

*The proposal has a neutral impact on this objective.*

## Impact on Core Industry Documents

5.12 The proposed modification does not impact on any core industry documents.

## Impact on Other Industry Documents

5.13 The proposed modification does not impact on any other industry documents.

## Implementation

5.14 The NETS SQSS Review Panel proposes that GSR014 should be implemented 10 business days after an Authority decision.

This section contains the proposed legal text to give effect to the proposals. The proposed new text is in red and is based on NETS SQSS Version 2.2.

### **7.13.1** *For Offshore Facilities Connected to the Onshore Transmission System using AC ~~Circuits~~ Cables*

**7.13.1.1** *With effect from 31<sup>st</sup> December 2015, in the case of new offshore power park module only connections, and where the offshore grid entry point capacity is 120MW or more, following a planned outage or a fault outage of a single AC offshore ~~transformer~~ transmission circuit at the onshore AC transformation facilities or between the onshore AC transformation facilities and the Onshore Transmission System, the loss of power infeed shall not exceed the smaller of either: 50% of the offshore grid entry point capacity; or the full normal infeed loss risk. (For the avoidance of doubt, connection offers signed by all parties before 31<sup>st</sup> December 2015 for connections which are configured with two AC transformers banked onto a single 400kV or 275kV switch-bay are deemed to be compliant with Section 7.13.1.1.)*

### **7.13.2** *For Offshore Facilities Connected to the Onshore Transmission System using DC ~~Circuits~~ Cables*

## Annex 2 - Consultation Responses

<b>Respondent:</b>	David Lyon The American Barns Banbury Road Lighthorne Warwickshire CV35 0AE Mob Tel: 07920573728
<b>Company Name:</b>	Blue Transmission Investments Limited
<b>Do you support the proposed implementation approach?</b>	Yes, subject to it not being retrospective to connections completed before 31st December 2014.
<b>Do you believe that GSR014 better facilitates the appropriate NETS SQSS objectives?</b>	Yes, subject to it not being retrospective to connections completed before 31st December 2014.  <i>For reference the applicable NETS SQSS objectives are:</i>  (i) facilitate the planning, development and maintenance of an efficient, coordinated and economical system of electricity transmission, and the operation of that system in an efficient, economic and coordinated manner;  (ii) ensure an appropriate level of security and quality of supply and safe operation of the National Electricity Transmission System;  (iii) facilitate effective competition in the generation and supply of electricity, and (so far as consistent therewith) facilitating such competition in the distribution of electricity; and  (iv) facilitate electricity Transmission Licensees to comply with their obligations under EU law.
<b>The proposal is underpinned by economic analysis of two designs for a range of scenarios. Has the analysis considered a wide enough range of scenarios and designs to reach a generic conclusion? Are the costs (capital and operational) and availability data used in the analysis reasonable?</b>	This would require detailed analysis/review which BTIL has not been involved in.

<p><b>The proposed modification is not intended to apply retrospectively to connections completed before 31st December 2014 and it is proposed that this qualifying date be introduced. Are you in agreement with this approach and date?</b></p>	<p>Yes it should not be retrospective to connections completed prior to the 31st December 2014 as this would incur significant capital costs and loss of generation associated with any modifications.</p>
<p><b>Do you agree with a proposed effective date of 1st January 2015 for these changes to come into effect?</b></p>	<p>Yes notwithstanding the above points.</p>
<p><b>The Working-Group report indicates that there are circumstances when the cost benefit analysis may demonstrate that a single bay option is economic for future connections. For example where an existing substation is not able to be extended, or requires uneconomic and extensive civil works. In these cases, the proposed modification will require that a lifetime derogation is required. Is this a reasonable requirement against the benefits of the proposal?</b></p>	<p>Yes this is reasonable.</p>
<p><b>What additional clarity or other benefits does the proposal bring to the criteria of the NETS SQSS?</b></p>	<p>No comment.</p>
<p><b>Do you support the proposed implementation approach of 10 business days following an Authority decision?</b></p>	<p>This time period is very limited and does not appear to offer sufficient time for appeal, is this standard?</p>
<p><b>Do you have any additional comments?</b></p>	<p>No.</p>



<b>Respondent:</b>	Nicola Barberis Negra <a href="mailto:nibne@dongenergy.co.uk">nibne@dongenergy.co.uk</a> +44 (0) 20 78 11 52 60
<b>Company Name:</b>	DONG Energy
<b>Do you support the proposed implementation approach?</b>	No, we believe that more work and a larger set of scenarios need to be considered before this proposal is approved. The wording of the proposed clause 7.13.1.1 also requires further considerations to avoid misinterpretation. A detailed explanation of our concerns is presented in the rest of this response.
<b>Do you believe that GSR014 better facilitates the appropriate NETS SQSS objectives?</b>	<p><i>For reference the applicable NETS SQSS objectives are:</i></p> <p><i>(i) facilitate the planning, development and maintenance of an efficient, coordinated and economical system of electricity transmission, and the operation of that system in an efficient, economic and coordinated manner;</i></p> <p><i>(ii) ensure an appropriate level of security and quality of supply and safe operation of the National Electricity Transmission System;</i></p> <p><i>(iii) facilitate effective competition in the generation and supply of electricity, and (so far as consistent therewith) facilitating such competition in the distribution of electricity; and</i></p> <p><i>(iv) facilitate electricity Transmission Licensees to comply with their obligations under EU law.</i></p> <p>We believe that more work and a large set of scenarios need to be considered for this CBA before this question can be answered. A detailed explanation of our concerns is presented in the rest of this response.</p>

**The proposal is underpinned by economic analysis of two designs for a range of scenarios. Has the analysis considered a wide enough range of scenarios and designs to reach a generic conclusion? Are the costs (capital and operational) and availability data used in the analysis reasonable?**

No, we believe that a more detailed assessment is required. The methodology used for the assessment seems sound (although we are not in the position to comment on each single calculation that has been performed): however, only a few cases are assessed here and it is our view that it is not possible to generalise the approach and amend the SQSS based on the scenarios considered in the group report. In particular, we have the following concerns:

1. The SQSS section 7.13.1.1 refers to wind farms with GEP capacity of 120MW or above. However, the study compares only wind farms with capacity at GEP of 250MW or above. The conclusion that a configuration with a double bay is the best solution for wind farms of sizes between 120 and 250MW cannot be drawn based upon the presented calculations, also given the fact that the presented results show a decrease in benefits of having two bays when the wind farm decreases its capacity.
2. Only connection to 400kV TIP is considered in this work: would the results be similar for connection to 275kV, given the difference in costs for cables, circuit breakers and transformers?
3. Have NGET's costs to provide connection for one or two bays within their GIS or AIS equipment been included in the assessment? What we refer to here is the skeletal bay that is needed to connect the wind farm bay to NGET's AIS or GIS substation (one per connection). We believe that this should be included as it would have an impact on the CBA results.
4. 400kV cable lengths between 50 and 250m are considered in this work: however, projects have connection with underground cables up to 600-700m. This would have an impact on both cable costs (which would increase) and cable availability (which is based on cable lengths). It is not possible to generalise the results in the way that has been presented in the consultation.

5. Offshore wind farms are sometimes required to install 275kV or 400kV filters and associated equipment at the TIP to mitigate harmonic issues. The need for this equipment may require the inclusion of additional banking or t-off connection to achieve a compliant solution and this could potentially reduce or completely eliminate the economic advantage of the proposed configuration via two bays. We believe this should be considered in the assessment of this consultation.
6. The proposed changes to clause 7.13.1.1 are not consistent with the assessment that is presented in the group report. The definition of "Offshore Transmission Circuit" includes cables, overhead lines, transformers and reactors. However, neither reactors nor overhead lines are considered in this assessment. Therefore, the proposed amended text should only refer to those components, 400kV cables and transformers, which have been included in the assessment. No considerations are given to reactors and overhead lines and therefore no reference to them should be used in the amended SQSS.
7. With respect to 6), the wording of the proposed amendment of clause 7.13.1.1 is not clear with respect to the export cables (i.e. at the LV side of the onshore transformers): export cables are included in the definition of "Offshore Transmission Circuit" and they physically terminate within the "onshore AC Transformation facilities". We are sure that this is not the intention of this proposal, but the way clause 7.13.1.1 is drafted, may lead to some misinterpretation if the fault of one export cable should not cause a loss of more than 50% of the offshore grid entry point capacity (which would also contradict clause 7.9).

NOTE: The term "onshore AC Transformation facilities" is not defined in the SQSS: it is assumed for the purpose of this response that it refers to the OTSDUW User or OFTO onshore substation facilities.

<p><b>The proposed modification is not intended to apply retrospectively to connections completed before 31st December 2014 and it is proposed that this qualifying date be introduced. Are you in agreement with this approach and date?</b></p>	<p>We do agree with the fact that this new proposal should not have any impact on wind farms that have already signed a grid connection agreement. We would also like to get a clarification regarding what “completed” means? Does it mean “connected and generating power” or “with a complete grid connection agreement”? What happens to wind farms with a grid connection signed, but that have not been completed, e.g. connected yet? Is this addressed in the paragraph between brackets in the new 7.13.1.1? We believe that the word complete should be replaced by wording that reflects better the intention of this sentence.</p> <p>We would like to have further clarifications regarding what will happen if a Mod App is submitted: would the amended SQSS clause apply in this case? We believe that it should not apply, as projects who apply for a Mod App may have already reached a level of development, for instance planning consent already submitted or approved or main equipment under procurement that a change of design from one to two bays would cause serious delays. It is our opinion that this amendment should apply to projects who only apply for a new grid connection agreement or for those projects which already have a grid connection agreement it should be made optional to be compliant with the amended clause 7.13.1.1 of the SQSS, without further justification required.</p> <p>Moreover, should a project have a connection via a single bay and apply for a Modification Application of an existing grid connection agreement, no requirement should be imposed to the OTSDUW User to justify its pre-existing single-bay connection in the CION document or to apply for a lifetime derogation, should this proposed SQSS amendment be approved.</p>
<p><b>Do you agree with a proposed effective date of 1st January 2015 for these changes to come into effect?</b></p>	<p>We believe that more work is required to show the benefits (if any) of this SQSS amendment and therefore do not think that by the proposed date of 1st January 2015 the SQSS amendment will receive sufficient support to become effective.</p>

<p><b>The Working-Group report indicates that there are circumstances when the cost benefit analysis may demonstrate that a single bay option is economic for future connections. For example where an existing substation is not able to be extended, or requires uneconomic and extensive civil works. In these cases, the proposed modification will require that a lifetime derogation is required. Is this a reasonable requirement against the benefits of the proposal?</b></p>	<p>We do agree that some flexibility should be retained to allow a connection via a single bay when a CBA demonstrates that a single bay option is more economic and would allow a project to meet its programme. However, the process for a lifetime derogation requires the following clarifications:</p> <ol style="list-style-type: none"> <li>1. Who applies for the derogation, if a derogation is required? Should this SQSS amendment be approved, we believe that it should be clearly stated who should apply for it. If the request for a single bay comes from National Grid, then we believe that National Grid should apply for it. OTSUDW Users or OFTOs should apply if they request this uncompliant solution.</li> <li>2. Derogation processes and especially their timescales are not specified in any Industry Code. There is a risk with this approach that the derogation will be granted after many months: this will risk delaying the design and procurement of equipment by both National Grid and OTSDUW Users/OFTOs, as no final decision can be made unless a decision for the derogation is made. This will risk delaying a project with serious impact on its feasibility.</li> </ol> <p>We believe that proposing a SQSS modification that implies that a lifetime derogation will be required does not support the offshore wind farm industry and adds unnecessary risks to their development. This is another reason why we are not supportive of this proposal in the way it is currently drafted.</p>
<p><b>What additional clarity or other benefits does the proposal bring to the criteria of the NETS SQSS?</b></p>	<p>No further comments.</p>
<p><b>Do you support the proposed implementation approach of 10 business days following an Authority decision?</b></p>	<p>No further comments.</p>
<p><b>Do you have any additional comments?</b></p>	<p>No further comments.</p>

<b>Respondent:</b>	Mark Perry <a href="mailto:mark.perry@nationalgrid.com">mark.perry@nationalgrid.com</a> 01926 655468
<b>Company Name:</b>	National Grid Electricity Transmission
<b>Do you support the proposed implementation approach?</b>	No, further work is needed to demonstrate that there is consumer benefit to the proposals.
<b>Do you believe that GSR014 better facilitates the appropriate NETS SQSS objectives?</b>	At present, there are a number of concerns around the analysis undertaken to support the proposal. As a result, it is not clear that it will benefit the consumer by ensuring more economic development of the overall transmission system. The NETS SQSS currently allows for different designs to be compliant. The proposals will reduce the flexibility, potentially leading to the requirement for derogation in some economic cases.
<b>The proposal is underpinned by economic analysis of two designs for a range of scenarios. Has the analysis considered a wide enough range of scenarios and designs to reach a generic conclusion? Are the costs (capital and operational) and availability data used in the analysis reasonable?</b>	<p>The cost benefit analysis appears to have been based on comparing the cost of additional investment with savings in operational costs due to the higher availability of wind farm connections to the transmission system. The operational cost savings include reduced constraint payments to the wind generators. At present, constraint payments are not made to offshore wind farms when there is reduced availability of the OFTO network and so there is no cost to the consumer in constraining offshore wind generation, other than the cost of replacement (onshore) generation. ROCs are not paid when the generator is constrained, nor will CfDs be paid. Consequently, to assess the impact of the proposal on the consumer, the CBA should take account only of the cost of the replacement generation and any adjustments to ROC / CfD payments. Analysis on this basis may lead to a different conclusion.</p> <p>The capital costs are reflective of those likely to be seen in the majority of connections. However, on occasion the cost difference between a single bay and double bay connection may be significant, for example where substation extension is required for the second bay and may fall outside the range of costs considered.</p>

<p><b>The proposed modification is not intended to apply retrospectively to connections completed before 31st December 2014 and it is proposed that this qualifying date be introduced. Are you in agreement with this approach and date?</b></p>	<p>Yes. It is unlikely that economic benefit would be seen in retrospective development of additional connections and I would expect derogation to be sought for any connections that do not meet the proposed standard. There is no obvious benefit to any party in requiring derogations for existing wind farms.</p>
<p><b>Do you agree with a proposed effective date of 1st January 2015 for these changes to come into effect?</b></p>	<p>If the changes are implemented, this date seems reasonable.</p>
<p><b>The Working-Group report indicates that there are circumstances when the cost benefit analysis may demonstrate that a single bay option is economic for future connections. For example where an existing substation is not able to be extended, or requires uneconomic and extensive civil works. In these cases, the proposed modification will require that a lifetime derogation is required. Is this a reasonable requirement against the benefits of the proposal?</b></p>	<p>The NETS SQSS currently allows for both single bay and two bay connections to be compliant. The decision on the preferred option is based on cost benefit analysis of the specific case. The proposal will not change the conclusion of any analysis and therefore should not change the connection option that is developed. It therefore appears that the requirement for derogation in cases where a single bay connection is the economic option may be the main consequence of the proposal. This does not provide benefit to the consumer or industry parties.</p>
<p><b>What additional clarity or other benefits does the proposal bring to the criteria of the NETS SQSS?</b></p>	<p>None.</p>
<p><b>Do you support the proposed implementation approach of 10 business days following an Authority decision?</b></p>	<p>Yes, if the proposals are implemented.</p>
<p><b>Do you have any additional comments?</b></p>	<p>Further work is needed to fully understand whether the consumer will benefit from the additional costs incurred should the proposal be implemented. This further work should take account of the mechanisms currently in place around the payment of offshore generation during constrained operation, including constrained energy and ROC/CfD payments.</p>



<b>Respondent:</b>	Joseph Dunn <a href="mailto:Joseph.Dunn@scottishpower.com">Joseph.Dunn@scottishpower.com</a> Tel: +44 (0) 7753624494
<b>Company Name:</b>	Scottish Power Renewables
<b>Do you support the proposed implementation approach?</b>	No. We believe the current wording can be subject to misinterpretation and the proposal is based on a very limited set of criteria / scenarios and inputs. This is expanded upon below.
<b>Do you believe that GSR014 better facilitates the appropriate NETS SQSS objectives?</b>	<p><i>For reference the applicable NETS SQSS objectives are:</i></p> <p><i>(i) facilitate the planning, development and maintenance of an efficient, coordinated and economical system of electricity transmission, and the operation of that system in an efficient, economic and coordinated manner;</i></p> <p><i>(ii) ensure an appropriate level of security and quality of supply and safe operation of the National Electricity Transmission System;</i></p> <p><i>(iii) facilitate effective competition in the generation and supply of electricity, and (so far as consistent therewith) facilitating such competition in the distribution of electricity; and</i></p> <p><i>(iv) facilitate electricity Transmission Licensees to comply with their obligations under EU law.</i></p> <p>Taking each in turn:</p> <p>(i) We do not believe there is sufficient evidence presented to demonstrate that the proposed changes will lead to reduce costs and more economic operation over the lifetime of the offshore transmission. This note is expanded on below.</p> <p>(ii) We do not believe there is sufficient evidence presented to demonstrate that the proposed changes will lead to increase the overall level of security of the NETS. This note is expanded on below.</p> <p>(iii) We believe that this proposal could negatively impact this objective whereby schemes are put at a disadvantage unnecessarily according to their capacity and requirement for potential uneconomic overbuild. This note is expanded on below.</p>



	<p>(iv) We believe the proposal has a neutral impact on this objective.</p>
<p><b>The proposal is underpinned by economic analysis of two designs for a range of scenarios. Has the analysis considered a wide enough range of scenarios and designs to reach a generic conclusion? Are the costs (capital and operational) and availability data used in the analysis reasonable?</b></p>	<p>We do not believe the analysis considered or the scenarios are sufficient to reach a conclusion.</p> <p>Both of the designs provided in Figure 1 meet this requirement. However, in providing another example, a connection design that would meet this requirement (but is not considered in the work-group report) is a single switch-bay into which two transformer circuits are connected, but that each transformer is connected by a disconnecter rather than a circuit breaker. This option would be at a lower cost than Design 2, so the difference in NPV with Design 1 is likely to be less than stated in the report for Design 2. This could result in a different conclusion to the report.</p> <p>We do not believe the costs used in the analysis are correct, clear or sufficient.</p> <p>Section 2.5 of the consultation document states: "...The purpose of Section 7.13.1.1 is to ensure that in the event of a permanent fault on a transformer, the wind farm would not be completely disconnected from the transmission system for the duration of the transformer replacement time, which could be in the region of 18 months..." We consider the duration of the transformer replacement time stated in Section 2.5 to be excessive (18 months). If the CBA is based on this assumption, we do not consider the results to be accurate.</p> <p>The working-group report is not clear on the value of WACC used for the analysis and Spackman methodology. The Executive Summary of the consultation states "...The CBA calculated the cost benefit over the assumed twenty year life of the wind farm assuming a pre-tax weighted average cost of capital (WACC) of 7.9%, an interest during construction (IDC) rate of 7.9% and a social time preference rate (STPR) of 3.5%..." However, Section 5 of the work-group report states "...For the purpose of this analysis a WACC of 6.25% was used..."</p>

	<p>Whilst this may not change the conclusion of the report it would be beneficial to have the cost benefit analysis reviewed and verified to ensure it is using correct and consistent inputs.</p>
<p><b>The proposed modification is not intended to apply retrospectively to connections completed before 31st December 2014 and it is proposed that this qualifying date be introduced. Are you in agreement with this approach and date?</b></p>	<p>In principle, yes, we agree that such a modification should not apply to connections already contracted with agreed configurations. To add to this we note that greater clarification is required regarding the wording "...connections completed..."</p> <p>Such a requirement should not be applied to connections that are already "completed" and moreover should not be applied to connections that are in an advanced stage of development.</p> <p>The proposed legal text states "... (For the avoidance of doubt, connection offers signed by all parties before 31st December 2014 for connections which are configured with two AC transformers banked onto a single 400kV or 275kV switch-bay are deemed to be compliant with Section 7.13.1.1)... " so the criteria of the legal text does not align with the proposed modification.</p> <p>Equally, the relationship with NGET through the CUSC and subsequent quarterly reporting and application process must be considered whereby agreement has already been reached to modify the connection and at this time "awaits" formal application or offer. Similarly, criteria must be considered to include the consenting process where a specific configuration is in the process of being agreed.</p>
<p><b>Do you agree with a proposed effective date of 1st January 2015 for these changes to come into effect?</b></p>	<p>No. We believe the current proposals will unnecessarily limit the design options for offshore transmission connections.</p> <p>An alternative approach would be for the SQSS to allow the flexibility of a one or two switch-bay option and for an economical and technical assessment (CBA) to be completed on a project specific basis.</p>

<p><b>The Working-Group report indicates that there are circumstances when the cost benefit analysis may demonstrate that a single bay option is economic for future connections. For example where an existing substation is not able to be extended, or requires uneconomic and extensive civil works. In these cases, the proposed modification will require that a lifetime derogation is required. Is this a reasonable requirement against the benefits of the proposal?</b></p>	<p>It is agreed that in some circumstances the CBA may demonstrate that a single bay option is economic for future connections. It would therefore be our preference for the SQSS to allow the flexibility of a one or two switch-bay option and for an economical and technical assessment (CBA) to be completed on a project specific basis. This would be cleaner administratively than a requirement to obtain a lifetime derogation.</p>
<p><b>What additional clarity or other benefits does the proposal bring to the criteria of the NETS SQSS?</b></p>	<p>The proposal is not considered to bring any benefits and instead it unnecessarily limits the options available for offshore transmission connections.</p>
<p><b>Do you support the proposed implementation approach of 10 business days following an Authority decision?</b></p>	<p>No, the proposal should not be implemented.</p>
<p><b>Do you have any additional comments?</b></p>	<p>No further comments.</p>

<b>Respondent:</b>	Karstein Brekke Mobile Phone: +4790542619 Email: <a href="mailto:Karstein.Brekke@statkraft.com">Karstein.Brekke@statkraft.com</a>
<b>Company Name:</b>	Statkraft AS Wind Offshore
<b>Do you support the proposed implementation approach?</b>	No – see further comments below.
<b>Do you believe that GSR014 better facilitates the appropriate NETS SQSS objectives?</b>	<p><i>For reference the applicable NETS SQSS objectives are:</i></p> <p><i>(i) facilitate the planning, development and maintenance of an efficient, coordinated and economical system of electricity transmission, and the operation of that system in an efficient, economic and coordinated manner;</i></p> <p><u>Our Comment:</u> We consider the achievement of this objective largely to remain unchanged due to the proposed solution. To our understanding, also today with the existing requirement, one can and does install two bays when this is considered to be beneficial. On the other hand, the proposed solution seems to force a solution with two bays also in cases when this is not considered to be beneficial, hence, the proposal can lead to lower achievement of this objective. For the avoidance of doubt, we do not consider the new proposal to increase the achievement of this objective.</p> <p><i>(ii) ensure an appropriate level of security and quality of supply and safe operation of the National Electricity Transmission System;</i></p> <p><u>Our Comment:</u> The proposal could lead to a marginal increase in the security of supply for the onshore power system. However, this is only marginal, since the existing requirement already is covering cases with transformer faults. Faults in the cables between the onshore substation and the MITS, including the two bays, will have a much shorter mean-time-to-repair compared to a transformer.</p>

	<p>Furthermore, the existing requirement, also gives the opportunity for two bays, hence the increase in security of supply can probably be fully neglected. Furthermore, an “appropriate” level of security of supply can only be considered taking due account of costs related to achieving that level. We do not consider the proposal to influence on the quality of supply or the safe operation (...).</p> <p><i>(iii) facilitate effective competition in the generation and supply of electricity, and (so far as consistent therewith) facilitating such competition in the distribution of electricity; and</i></p> <p><u>Our Comment:</u> We do not consider the proposal to influence on this objective.</p> <p><i>(iv) facilitate electricity Transmission Licensees to comply with their obligations under EU law.</i></p> <p><u>Our Comment:</u> We do not consider the proposal to influence on this objective.</p>
<p><b>The proposal is underpinned by economic analysis of two designs for a range of scenarios. Has the analysis considered a wide enough range of scenarios and designs to reach a generic conclusion? Are the costs (capital and operational) and availability data used in the analysis reasonable?</b></p>	<p>We do not consider that the economic analysis performed will represent sufficient material to propose a general rule as according to the proposal. The analyses represent only those cases investigated or possibly the range in-between. We consider it, on the other hand, imperative to perform cost benefit analysis on each individual project. This should belong to the CION process in advance of National Grid issuing a connection offer. We read the existing requirement in the NETS SQSS to include the possibility for an individual judgement in each project, without a derogation process being necessary. With the new proposal there is a risk that the offshore wind farm will be connected to a sub-optimised (non-optimised) connection point, leading to unnecessary costs for the society as a whole.</p>

<p><b>The proposed modification is not intended to apply retrospectively to connections completed before 31st December 2014 and it is proposed that this qualifying date be introduced. Are you in agreement with this approach and date?</b></p>	<p>We recommend not implementing the proposal. However, should the proposal still be implemented, we agree that it should not apply retrospectively. In any case, we do not agree with the proposed date. See our comments below regarding a proper transition period.</p>
<p><b>Do you agree with a proposed effective date of 1st January 2015 for these changes to come into effect?</b></p>	<p>We recommend not implementing the proposal. However, should the proposal still be implemented it will be imperative to allow a proper transition period, taking due account of existing consent processes and projects development to date. Projects will not be able to absorb such a requirement with immediate effect without suffering costs and delays. If implemented, there should be a transition period of at least two years. (i.e. If implemented by 31st December 2014, the entry into force should only be 1st January 2017 or later, with reference to the date for signing the connection offer.</p>
<p><b>The Working-Group report indicates that there are circumstances when the cost benefit analysis may demonstrate that a single bay option is economic for future connections. For example where an existing substation is not able to be extended, or requires uneconomic and extensive civil works. In these cases, the proposed modification will require that a lifetime derogation is required. Is this a reasonable requirement against the benefits of the proposal?</b></p>	<p>This statement from the working-group shows that also in the future it will be beneficial for the society as a whole to allow some connections with a single bay solution. We consider it to be a very poor solution to enforce a derogation process on “normal solutions”. The possible derogation process has not been described and represents huge risks regarding costs and time and may also lead to projects being delayed only as a direct consequence of the derogation process itself. We agree that the optimum for each individual project will vary; hence, we suggest keeping the current requirements, which do allow for a single bay solution when beneficial and a two bay solution when beneficial. (i.e. We do not support the proposal. All issues related to a single or two bay solution should in any case be clear and included when a connection offer is being issued.)</p>
<p><b>What additional clarity or other benefits does the proposal bring to the criteria of the NETS SQSS?</b></p>	<p>What seems clear from reviewing the consultation documents is that individual CBAs for each project seems the most proper way forward to achieve the most cost efficient solutions from the society’s viewpoint. To our understanding, there is sufficient flexibility within the existing requirements to account for this.</p>

	Hence, we strongly recommend to keep the existing wording and to reject the new proposal.
<b>Do you support the proposed implementation approach of 10 business days following an Authority decision?</b>	See our comment above regarding the need for a proper transition period.
<b>Do you have any additional comments?</b>	<p>The working-group has analysed two design options, Design 1 (a two bay solution) and Design 2 (a single bay solution). However, the specific design can vary between projects. We consider it imperative to investigate the costs and benefits for an appropriate design in each specific project, to be able to fully comply with the objectives of the NETS SQSS. We consider this possibility to be fulfilled by the existing requirement. We consider the new proposal to put unnecessary constraints on projects in those cases where the new proposal does not represent a positive CBA. That being said, we do agree that Design 1 could represent (close to) a preferred design option in some or many cases but that also Design 2 will be used when considered beneficial. Even if we consider the existing provision to include sufficient flexibility to ensure cost efficient solutions, it should be considered whether it is more explicitly required to perform individual CBAs, although this should already be covered through the CION process.</p> <p>However, should you still envisage implementing the proposed text we recommend to keep the existing headline for Section 7.13.1. From the section hierarchy the content of this section should be clear and we do not see why you want to limit this to cables. We strongly recommend not including dates within the provision itself. This should be covered elsewhere. Furthermore, it is imperative to make the text even clearer in order to avoid offshore assets being interpreted to be embraced by this provision.</p>







500 MW																					0.84																			
WACC	6.25%																																							
STPR	3.50%																																							
CASE 1 VS 2 AIS																																								
																					COSTS (£m)																			
YEARS	1	2	3	4	5	6	7	8	9	10	11	12	13	14	15	16	17	18	19	20																				
Trans Inv Cost D1	5.50																																							
Trans Inv Cost D2	7.00																																							
Diff Trans Inv Costs	-1.50																																							
Annuity costs (6.25%)	-0.13	-0.13	-0.13	-0.13	-0.13	-0.13	-0.13	-0.13	-0.13	-0.13	-0.13	-0.13	-0.13	-0.13	-0.13	-0.13	-0.13	-0.13	-0.13	-0.13	-0.13																			
Const. costs D1	1.20	1.20	1.20	1.20	1.20	1.20	1.20	1.20	1.20	1.20	1.20	1.20	1.20	1.20	1.20	1.20	1.20	1.20	1.20	1.20	1.20																			
Const. costs D2	2.00	2.00	2.00	2.00	2.00	2.00	2.00	2.00	2.00	2.00	2.00	2.00	2.00	2.00	2.00	2.00	2.00	2.00	2.00	2.00	2.00																			
Diff constr. costs	-0.80	-0.80	-0.80	-0.80	-0.80	-0.80	-0.80	-0.80	-0.80	-0.80	-0.80	-0.80	-0.80	-0.80	-0.80	-0.80	-0.80	-0.80	-0.80	-0.80	-0.80																			
	-0.93	-0.93	-0.93	-0.93	-0.93	-0.93	-0.93	-0.93	-0.93	-0.93	-0.93	-0.93	-0.93	-0.93	-0.93	-0.93	-0.93	-0.93	-0.93	-0.93	-0.93																			
NPV (difference)	-13.27																																							
500 MW																																								
WACC	6.25%																																							
STPR	3.50%																																							
CASE 1 VS 2 GIS																																								
																					COSTS (£m)																			
YEARS	1	2	3	4	5	6	7	8	9	10	11	12	13	14	15	16	17	18	19	20																				
Trans Inv Cost D1	7.40																																							
Trans Inv Cost D2	9.40																																							
Diff Trans Inv Costs	-2.00																																							
Annuity costs (6.25%)	-0.18	-0.18	-0.18	-0.18	-0.18	-0.18	-0.18	-0.18	-0.18	-0.18	-0.18	-0.18	-0.18	-0.18	-0.18	-0.18	-0.18	-0.18	-0.18	-0.18	-0.18																			
Const. costs D1	1.15	1.15	1.15	1.15	1.15	1.15	1.15	1.15	1.15	1.15	1.15	1.15	1.15	1.15	1.15	1.15	1.15	1.15	1.15	1.15	1.15																			
Const. costs D2	2.30	2.30	2.30	2.30	2.30	2.30	2.30	2.30	2.30	2.30	2.30	2.30	2.30	2.30	2.30	2.30	2.30	2.30	2.30	2.30	2.30																			
Diff constr. costs	-1.15	-1.15	-1.15	-1.15	-1.15	-1.15	-1.15	-1.15	-1.15	-1.15	-1.15	-1.15	-1.15	-1.15	-1.15	-1.15	-1.15	-1.15	-1.15	-1.15	-1.15																			
	-1.33	-1.33	-1.33	-1.33	-1.33	-1.33	-1.33	-1.33	-1.33	-1.33	-1.33	-1.33	-1.33	-1.33	-1.33	-1.33	-1.33	-1.33	-1.33	-1.33	-1.33																			
NPV (difference)	-18.87																																							

















