

Guidance Notes for Power Park Modules

EU Code Users - Issue 4

June 2024

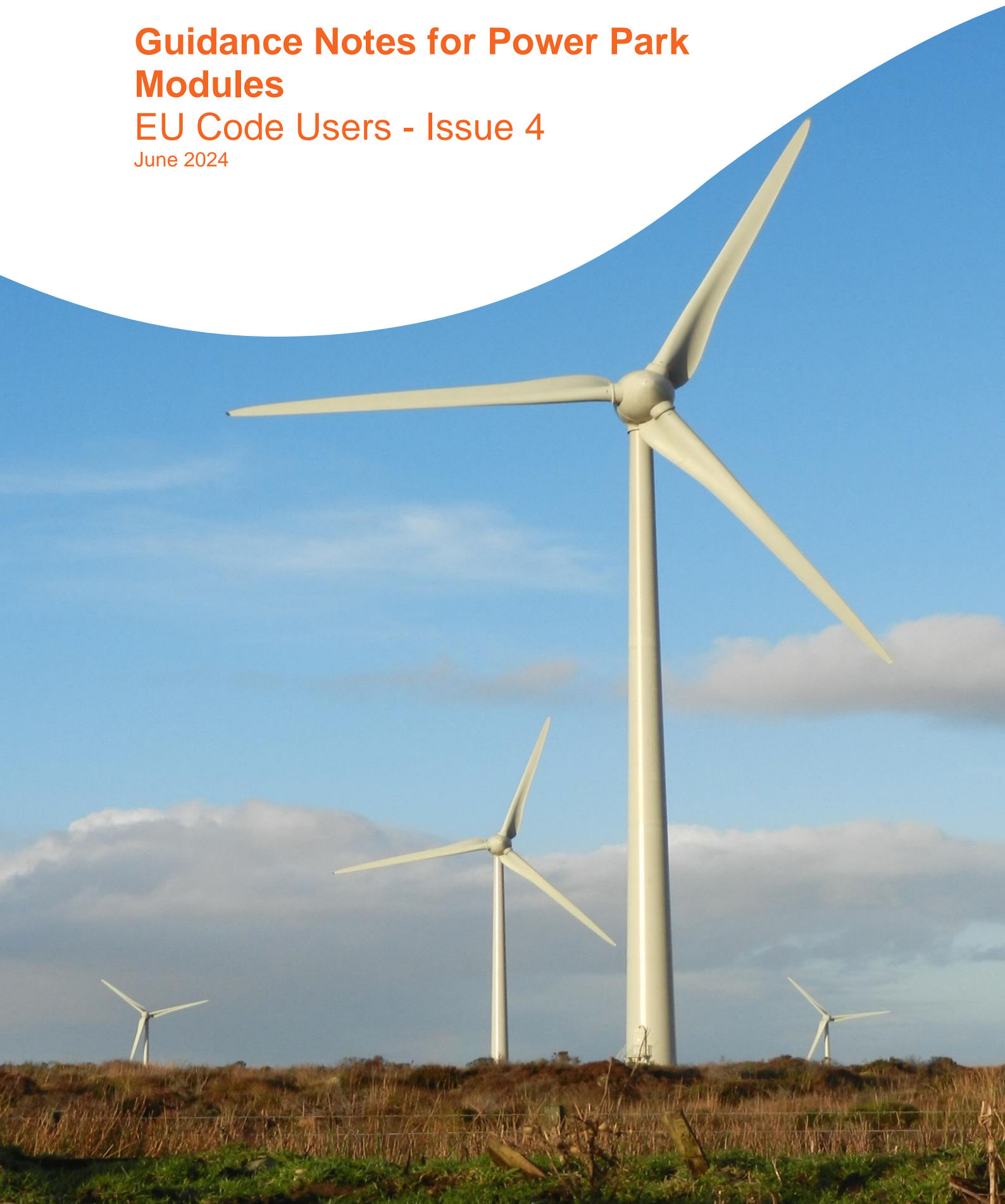

Foreword

These Guidance Notes have been prepared by the National Grid Electricity System Operator (ESO) to describe to Generators and other Users on the system how the Grid Code Compliance Processes is intended to work. Throughout this document National Grid refers to National Grid ESO (ESO) unless explicitly stated otherwise.

These Guidance Notes are prepared, solely, for the assistance of prospective Generators connecting directly to the National Electricity Transmission System or Large Embedded Power Stations. In the event of dispute, the Grid Code and Bilateral Agreement documents will take precedence over these notes.

Small and Medium Embedded Power Stations should contact the relevant Distribution Network Operator (DNO) for guidance.

These Guidance Notes are based on the Grid Code, Issue 6, Revision 23, effective from the 22 April 2024. They have been developed from Issue 3 of the Guidance Note of October 2021 and reflects the major changes brought about by Grid Code workgroup modifications GC0138 and GC0141 as approved by the regulator.

Definitions for the terminology used this document can be found in the Grid Code.

The Electricity Customer Connections Manager (see contact details) will be happy to provide clarification and assistance required in relation to these notes and on Grid Code compliance issues.

ESO welcomes comments including ideas to reduce the compliance effort while maintaining the level of confidence. Feedback should be directed to the ESO Electricity Connection Compliance team at:

David Lacey (Connections Compliance Manager)

Telephone: 07548112092

Email: david.lacey@nationalgrideso.com

Faraday House, Warwick

Disclaimer: This document has been prepared for guidance only and does not contain all the information needed to comply with the specific requirements of a Bilateral Agreement with National Grid. Please note that whilst these guidance notes have been prepared with due care, National Grid does not make any representation, warranty or undertaking, express or implied, in or in relation to the completeness and or accuracy of information contained in these guidance notes, and accordingly the contents should not be relied on as such.

© National Grid 2024

Contents

Foreword.....	1
Contents.....	2
Abbreviations	5
Guidance Notes	7
Introduction	9
Manufacturer’s Data & Performance Report	9
Compliance Process	10
Point of Compliance	11
Compliance Repeat Plan.....	11
Simulation Studies	12
Model Submission.....	12
Compliance Tests	13
ESO Data Recording Equipment.....	13
Compliance Test Signals.....	15
Compliance Test Log sheet.....	16
Future Development of Compliance Testing	16
ESO Register of Manufacturer’s Data & Performance Reports	16
Interim Operation.....	16
Test Notification to Control Room	17
Compliance Testing with Limited Power Source Availability.....	17
Compliance Testing of Power Stations Comprised of Identical Power Park Modules.....	17
Protection Requirements.....	17
Islanding Protection	18
Power Quality Requirements	18
Appendices	20
Appendix A: Reactive Capability	21
Summary of Requirements.....	21
Reactive Power MSA.....	21
Offshore Power Park Modules	22
Contractual Opportunities Relating to Reactive Services	23
Reactive Capability Compliance Tests.....	23
Appendix B: Voltage Control Testing	26

Summary of Requirements.....	26
Delivery of Reactive Capability Beyond $\pm 5\%$ Voltage.....	27
Transient Response	27
Variations in Voltage Control Requirements	28
Compliance Test Description	29
Suggested Power Park Module Voltage Control Test Procedure	29
Demonstration of Slope Characteristic.....	31
Additional Power System Stabiliser Testing.....	32
Suggested Power Park Module PSS Test Procedure.....	32
Appendix C: Frequency Control	35
Summary of Requirements.....	35
Modes of Frequency Control Operation	35
Target Frequency	38
De-load Instructions.....	38
Frequency Response from an Intermittent Power Source	39
Summary of Steady State Load Accuracy Requirements	39
Compliance Testing Requirements	40
Typical Frequency Control Test Injection	40
Power Level for Frequency Control Compliance Testing.....	41
Pre 70% Tests in Limited Frequency Sensitive Mode for Large Power Park Modules.....	41
Preliminary Frequency Response Testing	41
Frequency Response Testing Sequence	42
Generic Frequency Response Test Procedure.....	44
Control Requirements that may be witnessed	51
Appendix D: Power Park Unit Performance Registration and Fault Ride Through	53
Scope	53
Generic Power Park Unit Type Validation.....	53
Background to Generic Power Park Unit Type Validation.....	53
Confidentiality Provisions	55
Areas Suitable for Manufacturer's Data & Performance Report	55
Submitting Data into the Register of Manufacturer's Data & Performance Report	56
Summary of Grid Code Fault Ride Through Requirements	56
'Mode A' Requirements - first 140msec of a fault	56
'Mode B' Requirements - fault period beyond the first 140msec	57
Fast Fault Current Injection	57
Requirements for Induction Generators	58
Fault Ride Through Testing.....	58
Appendix E Response to Frequency Changes and Intermittent Power Source Variation.....	63
Scope	63
Frequency Sensitive Mode at Full Load.....	63
Set and Re-set Set-point.....	65

Frequency Sensitive Mode At De-Load	66
Limited Frequency Sensitive Mode	67
Summary	69
Appendix F Other Technical Information	71
Calculating Equivalent Impedance for Fault Ride Through Studies.....	71
Positive Sequence Studies.....	71
Negative Sequence Studies	72
Technical Information on the Connection Bus Bar	73
Equivalent Sequence Impedances for Calculating Unbalanced Short-Circuit Current Contribution	74
Appendix G Test Signal Schedule and Logsheet	75
Compliance Test Signal Schedules.....	75
Compliance Test Logsheet.....	76
Appendix H Contacting National Grid.....	78

Abbreviations

This section includes a list of the abbreviations that appear in this document.

Abbreviation	Description
AVC	Automatic Voltage Control (on transformers)
AVR	Automatic Voltage Regulator
BA / BCA	Bilateral Agreement / Bilateral Connection Agreement
BC	Balancing Code
BM / BMU	Balancing Mechanism / Balancing Mechanism Unit
CC / CC.A	Connection Conditions / Connection Conditions Appendix
CCGT	Combined Cycle Gas Turbine
CP	Compliance Processes
CSC	Current Sourced Converter
CUSC	Connection and Use of System Code
DC	Direct Current
DCS	Distributed Control System
DNO	Distribution Network Operator
DPD	Detailed Planning Data
DRC	Data Registration Code
ECC	European Connection Conditions
ECP	European Compliance Processes
EDL/EDT	Electronic Data Logging / Electronic Data Transfer
ELEXON	Balancing and Settlement Code Company
ESO	Electricity System Operator
FON	Final Operational Notification
FRT	Fault Ride Through
FSM	Frequency Sensitive Mode
GB	Great Britain
GCRP	Grid Code Review Panel
GEP	Grid entry point
ION	Interim Operational Notification
LSFM(O)	Limited Frequency Sensitive Mode (Overfrequency)
LSFM(U)	Limited Frequency Sensitive Mode (Underfrequency)

LON	Limited Operational Notification
MC	Maximum Capacity
MEL	Maximum Export Limit
MG	Minimum Generation
MLP	Machine Load Point
MRL	Minimum Regulating Level
MSOL	Minimum Stable Operating Level
NGESO	National Grid Electricity System Operator (same as 'ESO')
NGET	National Grid Electricity Transmission
OC	Operating Code
OFGEM	Office of Gas and Electricity Markets
OGEP	Offshore Grid Entry Point
PC	Planning Code
PSS	Power System Stabiliser
PSSE	Power System Simulator for Engineering software
RfG	Requirements for Generators (EU legislation)
RISSP	Record of Inter System Safety Precautions
SEL	Stable Export limit
SO	System Operator (same as 'ESO')
SPT	Scottish Power Transmission
SHET	Scottish Hydro Electric Transmission
STC	System Operator Transmission Owner Code
TO	Transmission Owner
TOGA	Transmission Outages, Generation Availability
UDFS	User Data File Structure
USEP	User System Entry Point

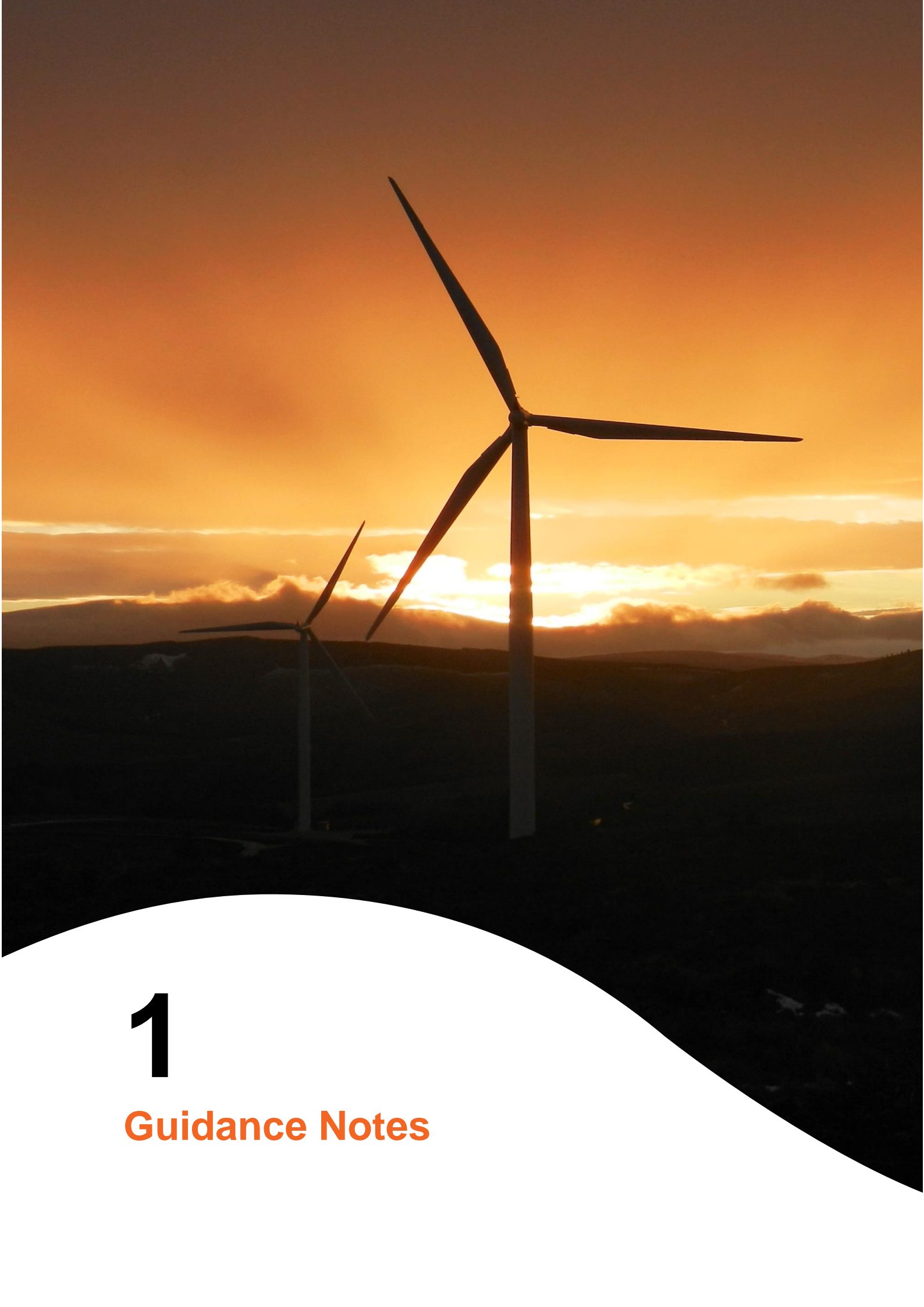

1

Guidance Notes

Introduction

This document complements the European Compliance Processes (ECP) included in the Grid Code providing additional description of the technical studies and testing set out within the Grid Code. An alternative guidance note addresses the Compliance Processes (CP) for GB Users.

To achieve Operational Notification, the Generator, the company owning and operating a Power Park, must demonstrate compliance with the Grid Code and Bilateral Agreement. The Grid Code is a generic document which specifies requirements regardless of local conditions. The Bilateral Agreement is a site-specific document agreed by ESO and the Generator, which for technical reasons, may specify additional/alternative requirements or specific parameters within a range indicated in the Grid Code. The total requirements placed on Generators are therefore the aggregation of those specified in the Grid Code and Bilateral Agreement.

This particular edition of the guidance notes has been written for new distributed generation technologies (such as wind farms or solar parks) referred to in the Grid Code as Power Parks Modules. The guidance notes contents are based on experience gained from wind turbines, but similar arrangements are expected to apply to other renewable technologies. An additional document exists that expands on guidance specifically for Electricity Storage modules. Guidance for conventional synchronous plants and HVDC converter equipment is provided separately.

For existing connections (connected prior to 27 April 2019) or who have placed purchase contracts for their main plant and apparatus prior to 17th May 2018 the Generator will be deemed a GB User and the new requirements in the European Connection Conditions (ECCs) will not apply. However, if an existing power station undertakes a significant modification to its plant or apparatus new requirements may become applicable. For example, should an existing wind turbine be replaced by a new model of turbine this will be required to meet the ECC.

The introduction of the ECC sections in the Grid Code introduced two new technical requirements for Power Park Modules. These new areas are:

- Limited Frequency Sensitive Mode for low frequency (LFSM-U) ECC.6.3.7.2
- Specification for Fast Fault Current Injection (FFCI) ECC.6.3.15.

In addition, a number of smaller updates have been made as a result of changes to the RfG requirements. The compliance with these areas is discussed within this guidance note.

Generators may, if they wish, suggest alternative tests or studies, which they believe will demonstrate compliance in accordance with the requirements placed on themselves and ESO.

Manufacturer's Data & Performance Report

Manufacturers are concerned with protecting their innovations and technologies employed in Power Park Units which if shared could compromise their competitive advantage. In order to facilitate the market, the power industry has agreed that some information can be supplied directly to ESO from Power Park Units manufacturers. The Grid Code (ECP.11) explains that ESO may receive manufacturer information and Generators can reference it as part of their compliance demonstration. Appendix D of these guidance notes provides additional information for Power Park Unit manufacturers.

Generators should note that using registered manufacturer data does not guarantee Grid Code compliance for a Power Park Module but does indicate that the Power Park Unit is capable of

achieving Grid Code compliance in the appropriate area. Any Generator wishing to use manufacturer data is advised to contact ESO early in the compliance process to determine if the information held in the Register of Manufacturer's Data & Performance Report is appropriate and sufficient in each case. This approach can be used for information relating to the dynamic model of a turbine or park controller and the data and reports associated with fault ride through type tests.

While Generators may not see the Manufacturer's Data & Performance Report information, they must ensure that the correct reference is used as the same provisions will apply to this data as a normal Data Registration Code or a User Data File Structure submission. The Manufacturer's Data & Performance Report reference given by the Power Park Unit manufacturer will contain the following:

- Manufacturer name.
- Power Park Unit type.
- Date; and
- The relevant report version number.

The User should then reference the document in the appropriate place in the User Data File Structure. For example, in case of fault ride through studies, assuming suitable fault ride through information is available in a Manufacturers Data and Performance report, the User can enter the following sentence;

"This information has been submitted generically to ESO and can be found in the ESO Register of Manufacturer's Data & Performance Report under document reference "manufacturerX_10MWturbintype1_22Aug08_reportver001"

Compliance Process

The process for Generators to demonstrate compliance with the Grid Code and Bilateral Agreement is included in the Grid Code European Compliance Processes (ECP). In addition to the process and details of the documentation that is exchanged, the appendices to the ECP include the technical details of the simulation studies that a Generator should carry out (ECP.A.3) and the details of compliance tests applicable to Power Park Modules (ECP.A.6). The compliance processes cross reference with other sections of the Grid Code, namely the Planning Code (PC) and the European Connection Conditions (ECC).

The PC sets out the data and information that a Generator is required to submit prior to connection and then maintain during the lifetime of the power station. The format for submission of the majority of this information is set out in the Data Registration Code (DRC).

The ECC set out the majority of the technical design requirements that a Generator is required to meet with site specific variations laid out in the Bilateral Agreement.

The ECP sets out the technical details of the tests which ESO requires to demonstrate compliance with the Grid Code.

The technical requirements for a power generating module is based on its size at the connection point. A Power Generating Module is defined in the Grid Code but in summary this is a Synchronous Power Generating Module or a Power Park Module. For the purposes of this document the emphasis is placed on Power Park Modules. These are categorised as follows:

Category	Boundaries
Type A	≥800W to <1MW and connected below 110kV
Type B	≥1MW to <10MW and connected below 110kV
Type C	≥10MW to <50MW and connected below 110kV
Type D	≥50MW or connected at 110kV or above.

Table 1: Plant categories according to EU Code

A power station as defined under the Grid Code would be classified as a large, medium or small power station. This could comprise of any combination of a Type A, Type B, Type C or Type D power generating modules. A power station consisting of multiple power generating modules of different sizes may require a different compliance process approach for each module. Where a customer chooses, the process applicable to the largest module may be applied to smaller modules if this is agreed in advance with ESO.

Point of Compliance

In concept Generators define the boundary at which compliance is demonstrated at the Grid Entry Point or User System Entry Point if connected to a Distribution System. This is the ownership boundary between the Generating Company assets and the public network. This is often the termination point in compact switchgear owned by a network licensee of a short cable owned by the Generator. In practical terms, if the cable has negligible impact on performance, then metering for Generator Control systems and signals for compliance assessment can be at the Generator end of this short cable. If the cable is considered as having a material effect on performance, then control and signal metering needs to be at the network owner's end of the cable. As a rule of thumb connection cables of less than 500m can be considered as negligible. Where cable lengths are significant line compensation may be considered as an alternative to taking signals directly from the connection point.

Compliance Repeat Plan

GC-0141 has introduced the requirement for users to restate compliance every 5 years, from the issuance of FON (ECP.8). Before the 5 years from FON have passed, ESO will notify the user to confirm continued compliance. To do so, the user will be required to submit the following:

- A Compliance Statement and a User Self Certification of Compliance signed by the user. If there are any requirements that have not been met, then a statement of these, together with a copy of the derogation.
- Detail of any changes to relevant Planning Code data (both Standard Planning Data and Detailed Planning Data) and DRC schedules

In case all requirements have been satisfactorily fulfilled, ESO will issue the user with a FON and the user can continue operation as before. In case of embedded plants, the notification will also be sent to the relevant Transmission Owner. However, in the case where requirements are not fulfilled and the user is deemed non-compliant, ESO will issue them a LON, and the relevant process will be followed. It may be that some restriction is imposed, until the user resolves the issues.

Simulation Studies

The simulation studies described in the European Compliance Processes (ECP.A.3), and Power Park Unit type tests and on-site tests described in the appendices, provide indicative evidence that the requirements of the Grid Code have been met. However, if the study requirements specified in the Grid Code are inappropriate to the technologies employed on a particular project the Generator should contact ESO to discuss and agree an alternative program and success criteria.

In general, simulation studies are required to:

- Demonstrate an expected compliant performance ahead of connection.
- Demonstrate the model supplied is a true and accurate reflection of the plant, as built.
- Demonstrate capability where it is impractical through testing as the effects on other system Users would be unacceptable.

The simulations must be based on the validated models supplied to ESO in accordance with Grid Code Planning Code Appendix sections, PC.A.5.4 and PC.A.9, and are to be submitted before issuing ION. Fault Ride Through studies are encouraged to be done using electromagnetic transient (EMT) models.

The user is free to choose the simulation software for their studies. However, in the case that the software used for simulation is different from the one submitted to ESO (see section Model Submission), the user will be required to showcase that the results from both align in a model validation/verification report. In the event the model does not produce the correct output, the data submission will be considered incorrect and not contractually compliant. ESO will confirm model accuracy using its power system analysis software.

In GC-0141, additional requirements have been added for Fault Ride Through studies, which can be found in ECP.A.3.5. Based on this, additional simulations may be needed covered in compliance process for the non-standard operational arrangement

Model Submission

To comply with the planning code requirements of the Grid Code, Users are required to provide to ESO, a validated model(s) which adequately represent the dynamic performance of their systems as demonstrated during the compliance process.

For connections in possession of a FON or an EON before the 1st of September 2022 the requirements detailed in PC.A.5.4.2 (a to h) of the Grid Code still apply.

For future connections, or those that had started the compliance process but had not received an EON by 1st September 2022 the modelling requirements detailed under PC.A.9 of the Grid Code apply.

For the avoidance of doubt, the User is also required to comply with any additional modelling requirements that might be included in the BCA, regardless of the planning code modelling section applicable to the connection.

For detailed recommendations and advice on the model(s) submission aimed at complying with PC.A.9 of the Grid Code please refer to “Guidance Notes on Modelling Requirements – GC0141 Grid Code Modification” by following the link below.

[Guidance Notes on Modelling Requirements - GC0141 Grid Code Modification](#)

Compliance Tests

Tests identified in ECP.A.6 of the Grid Code are designed to demonstrate, where possible, that the relevant provisions of the Grid Code and Bilateral Agreement have been met. However, if the test requirements described in ECP.A.6 are at variance with the Bilateral Agreement or the test requirements are not relevant to the plant type, the Generator should contact ESO to discuss and agree an alternative test program and success criteria.

For each test to be carried out the description and purpose of the test to be carried out, results required, the relevant Grid Code clause(s) and criteria of assessment are given in ECP.A.6. The Generator is responsible for drafting test procedures for the power station as part of the compliance process prior to the issue of the Interim Operational Notification (ION). ECP.A.6 and the appendices of these guidance notes provide outline test schedules which may assist the Generator with this activity.

ESO may require further compliance tests or evidence to confirm site-specific technical requirements (in line with the Bilateral Agreement) or to address compliance issues that are of particular concern. Additional compliance tests, if required, will be identified following ESO's review of submissions of User Data File Structure (UDFS).

The tests are carried out by the Generator, or by their agent, and not by ESO. However, ESO may witness some of the tests as indicated in ECP.A.6. Tests should be completed following the test procedures supplied in the UDFS prior to the issue of the FON unless otherwise agreed by ESO.

The Generator should also provide suitable digital monitoring equipment to record all relevant test signals needed to verify the Power Park Module performance in parallel with ESO recording equipment.

Further guidance is provided in the appendices of this document.

ESO Data Recording Equipment

ESO will provide a digital recording instrument on site during the tests witnessed by ESO. A generic list of signals to be monitored during ESO witnessed tests is tabulated in ECP.A.4.3. This will be used to monitor all plant signals at a sampling rates indicated in ECC.6.6.3. The station should provide its own digital recording equipment to record the same plant variables. This will provide a back up to the test results should one of the recording instruments fail at the time of testing.

The station is responsible for providing the listed signals to the User's and ESO's recording equipment. For ESO purposes, the signals provided are required to be in the form of dc voltages within the range -10V to +10V (see ECC.6.6.3). The input impedance of the ESO equipment is in the region of 1M Ω and its loading effect on the signal sources should be negligible.

The station should advise ESO of the signals and scaling factors prior to the test day. A form of a typical test signal schedule is shown below:

Signal	Unit	Voltage Range	Signal Representation
Active Power Output	MW	0 to 8V	0 to Reg. Capacity
Reactive Power Output	Mvar	-8V to +8V	- Reg Capacity to +Reg Capacity
Terminal Voltage	kV	0V to 8V	Nominal Voltage –10% to Nominal Voltage +10%
System Frequency	Hz	-8V to 8V	48.0Hz – 52Hz
List of other signals.....			

Table 2: A typical test signal schedule

It may be appropriate for ESO to set up the recording equipment on the day prior to the test date. The station representatives are asked to ensure that a 230V single phase AC power supply is available and that the signals are brought to robust terminals at a single sampling point. Examples of ideal connection points with BNC or 4mm banana plug connections are shown in the following picture.



Figure 1: Example of Compliance Test Signal Connections

At sites where there are multiple Power Park Modules it may be advantageous for the Power Park developer to cable the signals for several Power Park Modules to a single point. This may allow simultaneous testing of multiple Power Park Modules maximising usage of periods of high wind and shortening overall test times. Where possible the person initiating the test injection signal (usually the manufacturer), the test co-ordinator (usually the owner) and the ESO monitoring signals should be in the same room to minimise co-ordination issues during witness testing.

The Power Park developer must inform ESO if the signal ground (0V) is not solidly tied to earth or of any other potential problems which may impact on the quality of the signals to be recorded.

With Power Park Modules, where sometimes real time analogue signals cannot be outputted from the control scheme, the Grid Code ECP.A.4.3.1(a) allows for the basic signals to be supplied directly from transducers connected to CTs/VTs on the interface circuit. The transducer(s) should be permanently installed at the Users location to easily allow safe testing at any point in the future, and to avoid a requirement for recalibration of the CTs / VTs. All the signals should then be available from the Power Park control systems as a download once the testing has been completed as described in ECP.A.4.3.1 (b) and (c).

The four basic signals are:

1. Total MW
2. Total MVar
3. Point of connection line-line Voltage (HV) (kV)
4. System frequency (Hz)

For offshore Power Park Modules, the control and signals for the witnessing of all testing should be available at the onshore connection (Interface) point to avoid the risks associated with offshore working. For offshore Power Park Modules the real time signals for witnessing tests are measured at the onshore Interface Point as illustrated in the following diagram and mentioned in ECP.A.4.3.3 (iii).

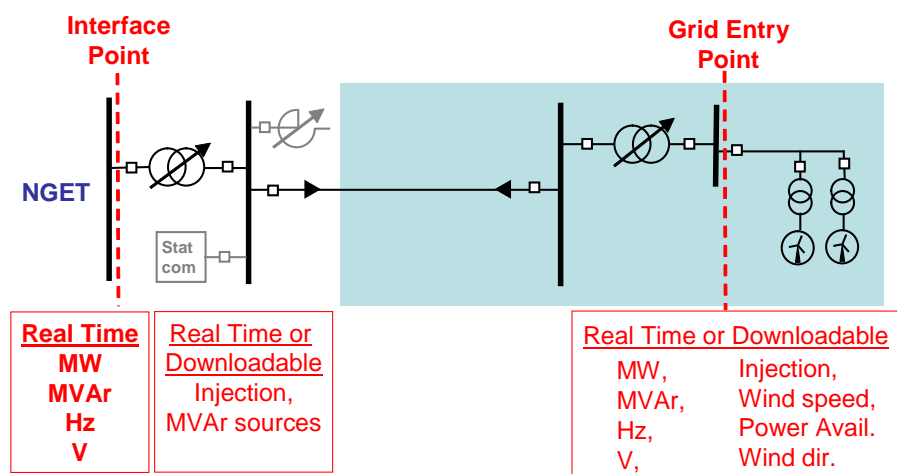

Figure 2: Typical Signals for offshore windfarm testing

Compliance Test Signals

The Grid Code requires that a number of signals are provided from compliance tests to ESO to allow assessment of the compliance. The list of these signals are set out in ECP.A.4 for EU Code Users.

Where these signals are provided to ESO, it should be done in a consistent electronic format with a time stamp in a numerical format which can be interpreted in Excel. To facilitate efficient analysis the test results should include signals requested by ESO set out in the columns order as indicated in the tables in Appendix G.

- Signals for non-witness tests should be provided in excel format and in the order and format presented in Appendix G unless otherwise agreed, in advance, with ESO.
- Where any additional test signals to those indicated in the tables are presented these should only be added with the agreement of ESO and be entered within the files as additional columns to the right of the required signals.
- Where a signal cannot be provided, and this has been agreed with ESO in advance of the tests, a blank column should be retained within the data.
- Where additional signals are included or the signals are presented but not in the arrangement detailed above the data may be rejected and the customer will be asked to resubmit the data in the agreed format.

Compliance Test Log sheet

Where test results are completed without any ESO presence but are relied upon as evidence of the compliance they should be accompanied by a log sheet. This sheet should be legible, in English and detail the items set out in Appendix G.

Future Development of Compliance Testing

ESO recognises that organising of witness site tests can lead to delays in progressing connections through the compliance process. We are looking at options to deliver the same confidence while reducing the need to attend site and witness tests in the future. This would require the support of manufacturers and owners in a number of areas which are summarised below:

- A suitable interface which allows ESO a view of the key test parameters graphically in real-time from the ESO office in Warwick. This would effectively provide the view of tests currently achieved by ESO connecting its recording equipment while at site.
- Where ESO has decided to allow testing without real-time witnessing for compliance testing with lower materiality, such as repeat tests. In such circumstances manufacturers or developers must provide all the test data to ESO in the standard format set out in the guidance note complete with an appropriate test log sheet.
- Where ESO has decided that the design of a Generators plant and apparatus is standardised, and the compliance can be evidenced by reference to a generic set of tests completed and accepted previously. This could be reference to Equipment Certificates where these have been accepted by ESO. This process will be offered provided in ESO's opinion it does not pose a material risk in terms of the specific site installations.

ESO will raise this during the compliance process and are open to suggestions from Developers. For manufacturers looking to suggest options or develop systems to facilitate remote witnessing please discuss with your compliance contact or contact ESO using the details in this guidance note.

ESO Register of Manufacturer's Data & Performance Reports

Users may wish to reference data held in the ESO Register of Manufacturer's Data & Performance Reports to help to complete various parts of the compliance process (see previous section of this document). This can be achieved by placing the manufacturer document reference in the appropriate place in the Data Registration Code or User Data File Structure. This reference should be obtained by the User from the Power Park Unit manufacturer. Please note that it is the responsibility of the User to ensure that the correct reference is submitted to ESO.

Even though different Power Park Modules may be comprised of the same Power Park Unit type, differences in performance can result. Submitting a Register of Manufacturer's Data & Performance Report reference can therefore not be a guarantee of compliance, and the suitability of the reference should be discussed with ESO as part of the normal compliance process.

Interim Operation

As there may be a considerable period between commissioning the first and last power Park Unit within a module, the Grid Code European Compliance Processes (ECP) provides two capacity restrictions during commissioning. These restrictions are managed by items included in the Interim Operation Notification (ION). The Generator is required to complete basic voltage control and

frequency response tests and have the results approved by ESO in order to have the capacity restrictions released.

Test Notification to Control Room

The Generator is responsible for notifying the 'ESO Control Centre' of any tests to be carried out on their plant, which could have a material effect on the National Electricity Transmission System. The procedures for planning and co-ordinating all plant testing with the 'ESO Control Centre' is detailed in OC7.5 of the Grid Code (i.e. Procedure in Relation to Integral Equipment Tests). For further details relating to this procedure, refer to "Integral Equipment Tests – Guidance Notes" which can be found on ESO's Internet site in Grid Code, Associated Documents.

The Generator should be aware that this interface with ESO transmission planning will normally be available in weekday working hours only. As best practice, the Generator should advise the 'ESO Control Centre' and in Scotland the relevant Transmission Owner, or Distribution Network Operator (if embedded) of the times and nature of the proposed tests at the earliest stage possible and where possible with 28 days' notice. If there is insufficient notice or information provided by the Generator, then the proposed testing may not be allowed to proceed.

Compliance Testing with Limited Power Source Availability

Many of the compliance tests require operation at a significant proportion of Rated MW. An Interim Operational Notification extension may be provided to allow operation until sufficient resource is available to complete the compliance tests at a suitable level of generation. In some cases the compliance tests may be approved at reduced capacity provided ESO are satisfied that the Power Park Module capability is sufficiently supported by generic type validation tests and site design data.

Compliance Testing of Power Stations Comprised of Identical Power Park Modules

Where a Power Station is comprised of two or more identical Power Park Modules, ESO may allow reduced compliance testing on the remaining Power Park Module(s) provided that the first Power Park Module successfully completed the full testing.

Protection Requirements

Under section ECC.6.2.2.2 of the Grid Code, the Generator must meet a set of minimum protection requirements. As part of the User Data File Structure content, the Generator should submit a Generator Protection Settings report together with an overall trip logic diagram.

The Generator should provide details of all the protection devices fitted to the Power Park Module and Power Park Units together with settings and time delays, including:

Protection Fitted	Typical Information Required
Under / Over Frequency Protection	Number of stages, trip characteristics, settings and time delays
Under / Over Voltage protection	Number of stages, trip characteristics, settings and time delays
Over Current Protection	Element types, characteristics, settings and time delays

Control Trip Functions	Functional Description, Control Characteristic and trip settings
Islanding Protection (see below)	Type, description, settings and time delays

Table 3: List of some protection details to be submitted

Islanding Protection

ROCOF protection should be disabled for directly connection and if islanding protection is required, an inter-tripping scheme is recommended. For Embedded generation, Islanding protection should be set in line with the G59/G99 requirement.

As stated in ECC.6.1.2, the System Frequency could rise to 52Hz or fall to 47Hz. The generator must continue to operate within this Frequency range for at least the periods of time given in ECC.6.1.2, unless ESO has specified any other requirements. Plant Owners will be responsible for protecting their equipment. If the frequency range is outside the range 52Hz to 47Hz, it is up to the Plant Owner to decide whether to disconnect their apparatus in England and Wales, non-synchro and PPM in Scotland shall be tripped according to the Grid Code.

Power Quality Requirements

For Power Parks that are to be connected to the National Electricity Transmission System, the harmonic distortion and voltage fluctuation (flicker) limits are set out in accordance with the Grid Code and Bilateral Agreement. The Transmission Owner is required to meet the relevant terms of the Grid Code.

With respect to harmonics, the Grid Code ECC.6.1.5(a) requires that the Electromagnetic Compatibility Levels for harmonic distortion on the Transmission System from all non-linear sources under both planned outage and fault outage conditions, (unless abnormal conditions prevail) shall comply with the compatibility levels given in Appendix A of Engineering Recommendation G5/4. The Grid Code further requires that the planning criteria contained within Engineering Recommendation G5/4 be applied for the connection of non-linear sources to the Transmission System, which result in harmonic limits being specified for these sources in the relevant Bilateral Agreement.

With respect to voltage fluctuations, it is also a requirement of the Grid Code that voltage fluctuations are kept within the levels given in Grid Code ECC.6.1.7 and/or Table 1 of Engineering Recommendation P28 issue 2 and therefore limits on voltage fluctuations are also specified in the relevant Bilateral Agreement. The Power Park Developer will be required to comply with the harmonic and voltage fluctuation limits specified in the Bilateral Agreement. The Transmission System or Distribution Network Operator will monitor compliance with these limits.

Development schemes with non-linear element(s) are assessed by the Transmission Owner for their expected impact on the harmonic distortion and voltage fluctuation levels. For harmonic voltage distortion, the process detailed in Stage 3 of Engineering Recommendation G5/4 is applied. For the voltage fluctuation, the principles outlined in Engineering Recommendation P28 issue 2 are used, with contribution from the Power Park being calculated according to the International Electrotechnical Commission standard IEC61400-21.

Specific information required for the assessment of harmonic voltage distortion and voltage fluctuation is detailed in Grid Code DRC.6.1.1. Any component design parameters for planned reactive compensation for the Power Park Module as detailed in Grid Code PC.A.6.4.2 should also be included giving due attention to tuned components.

For Power Parks Modules that are to be connected to Distribution Systems, Distribution Network Operators may undertake similar assessments to comply with the requirements of the Distribution Code in terms of harmonic distortion and voltage fluctuation.



A

Appendices

Appendix A: Reactive Capability

Summary of Requirements

The Reactive Capability requirements for a Power Park Module are specified in Grid Code ECC.6.3.2.

In summary, the first part of the requirement is for the Power Park Module to be capable of operating with no reactive power transfer to the public power system (with a tolerance within +/-5% of active power output) from zero power output to full output. The second part of the requirement is for the Power Park Module to be capable of operating with a range of reactive power outputs when producing more than 20% real power. This reactive power capability at the connection point is illustrated in the Figure ECC.6.3.2.4 I.

Below 20% real power output, the Power Park Module may continue to modulate reactive power transfer under voltage control or switch to zero reactive power transfer. If there is a switch to zero reactive power transfer, the Grid Code requires that there is a smooth transition between Voltage Control at active power levels greater than 20% and reactive power control at active power levels less than 20%.

Grid Code ECC.6.3.2.4.3 states that the reactive power capability must be fully available at all system voltages in the range $\pm 5\%$ of nominal. Generators connected at 33kV or below, are only required to meet the relaxed voltage/reactive capability envelope shown in Figure ECC.6.3.2.4(b). This relaxation recognises that the power park developer does not have control of a transformer tap changer to control voltages within his network. The ECC.6.3.2.4.3 capability is not normally tested but is demonstrated by simulation.

In the event that during system incidents (i.e. the voltage is $\leq 95\%$ or $\geq 105\%$) plant should deliver the maximum (lagging or leading respectively) reactive power possible, whilst remaining within its design limits.

Reactive Power MSA

The reactive capability tests enable a mandatory services agreement (MSA) table to be drafted on the basis of the plant's performance. The MSA table lists the maximum leading and lagging reactive power achieved at the Boundary Connection Point or USEP for a number of active power setpoints. Before the tests, during the study phase, an interim MSA is drafted, and this is later on replaced by the post-test MSA that is more realistic. Below is an example of an MSA table for a Power Park Module of convertor-controlled Power Park Units, where the reactive capability still exists below 20% power but not necessarily if the Power Park Units are stopped:

TABLE B	MW	LEAD (Mvar)	LAG (Mvar)
AT RATED MW	69	23	23
AT 50% (MW)	35	23	23
AT 20% (MW)	13	23	23
AT <20%	5	23	23
AT 0MW	0	0	0

Table 4: Sample reactive power MSA table

The development of the MSA table for offshore schemes differs from that onshore and is discussed later in this chapter.

Offshore Power Park Modules

The Grid Code requires offshore Power Park Modules, where there is an offshore Transmission System, to operate with zero reactive power transfer at the Offshore Grid Entry Point (OGEP) (ECC.6.3.2.5)¹. This is on the assumption that transferring reactive power through a long cable is not efficient. Other operating regimes such as control of reactive power at an offshore Grid Entry point or contribution to modulation of reactive power at the onshore Interface Point may be approved by ESO if this is demonstrated by the developer as being beneficial considering both capital and operational costs. Please see Figure 2 for the general location of TIP and OGEP for offshore PPMs.

MSA for Offshore Power Park Modules

While there is a requirement for the connection to provide reactive power at the TIP, as defined by Figure-ECC.6.3.2.4(c), this requirement is for the OFTO. Therefore, there is no MSA for it.

The MSA for the offshore plant is based on the reactive power at the Commercial Boundary (which, as per the definition in the CUSC, is at the HV side of the offshore transformer). As mentioned above, even though ECC.6.3.2.5 requires zero reactive power at the Offshore Grid Entry Point, other schemes may be agreed with the ESO and OFTO. As such, these schemes are broadly divided into four scheme categories, listed in the table below, and the MSAs are defined accordingly.

Configuration 1 Offshore PPMs				
	Reactive Power at IP	Reactive Power at OGEP	MSA	Testing Requirement
Sch. 1	Provided wholly by the OFTO	0 MVAR, provided by Offshore PPM. Cable gain compensated by assets (such as shunt reactors)	Zero	ECP.A.6.8
Sch. 2	Provided wholly by the OFTO	Some reactive power provided by Offshore PPM to compensate for cable gain	Yes (see discussion below)	ECP.A.6.4
Sch. 3	Provided wholly by Offshore PPM (on behalf of OFTO)	Some reactive power provided by Offshore PPM to cover for both cable gain and to fulfil requirements at IP	Yes	ECP.A.6.4
Sch. 4	Provided in part by OFTO and in part by Offshore PPM	Some reactive power provided by Offshore PPM to cover for both cable gain and to fulfil requirements at IP	Yes	ECP.A.6.4

Table 5: Schemes of Configuration 1 Offshore PPMs

Scheme 1 is the recommended scheme in the Grid Code. Since the PPM provides zero reactive power at the OGEP, the MSA is a table of zeroes.

¹ Please note that this only applies to Configuration 1 PPMs. MSAs for Configuration 2 should be discussed with the ESO

In Scheme 2, the PPM provides reactive power at the OGEP to compensate for the cable gain. However, since it does not contribute to reactive power at the TIP, the MSA table has little significance.

Schemes 3 and 4 are where the PPM contributes, at least in part, to reactive power at the TIP. The MSA tables are drafted depending on the reactive power at the commercial boundary.

When carrying out the reactive capability tests at the Transmission Interface Point (TIP) onshore, the measurements for the output from the offshore wind turbines should also be requested. This will help establish the full picture.

Contractual Opportunities Relating to Reactive Services

For some technologies there is an opportunity to provide an optional reactive service (beyond the basic mandatory reactive service) covering the period when the renewable energy source is not available (e.g. when a wind turbine has no wind). Developers interested in providing such a service should take the opportunity of reactive capability testing to demonstrate this zero power reactive capability. The delivery of reactive power would be expected to be dynamic, i.e. responding to changes to system voltage in the same manner as normal operation.

Reactive Capability Compliance Tests

Grid Code ECP.A.6.4 describes the Reactive Capability testing. The required tests should demonstrate the maximum capability of the Power Park Module beyond the corners of the envelope as shown in Grid Code Figure ECC.6.3.2.4 (c) Given the steady state nature of the Reactive Capability requirements implying that reactive output can be maintained indefinitely, the tests are carried out over a longer period than other compliance tests.

The aim of the test is to capture performance of the Power Park Modules at or as close to full output as possible recognising there are the obvious issues with wind forecasting. In order that the Generator has maximum opportunity to take advantage of periods of high wind/Tidal Flow/Sunlight etc and recognising the steady state nature of these tests, the Reactive Capability test is not usually witnessed by a ESO compliance engineer.

Grid Code ECP.A.6.4.1 sets a minimum power output level for carrying out the tests of 85% of Registered Capacity. If the Power Park Modules output is below this, the test should not be scheduled or attempted. Assuming power output is greater than 85% output with a good forecast for the hour ahead then the test can commence. Some variability in output below the 85% may be accepted. For the two tests at maximum power, the available output should not fall below 60%, as indicated by ECP.A.6.4.5.

In order to demonstrate that a Power Park Module can satisfy the reactive capability requirements it is necessary to perform reactive capability tests as set out in ECP.A.6.4.5. An example of a corresponding test schedule is shown below.

Test No	Step	Description	Notes
1		<ul style="list-style-type: none"> Plant in Voltage Control Initial operation must be in excess of 85% Maximum Capacity Operation in excess of 60% Maximum Capacity <u>throughout</u> Target Voltage (*) selected to generate a maximum continuous lagging Reactive Power for 30 minutes. 	
2		<ul style="list-style-type: none"> Initial operation must be in excess of 85% Maximum Capacity Operation in excess of 60% Maximum Capacity throughout Target Voltage (*) selected to generate a maximum continuous leading Reactive Power for 30 minutes. 	
3		<ul style="list-style-type: none"> Operation at 50% Maximum Capacity Target Voltage (*) selected to generate a maximum continuous leading Reactive Power for 30 minutes. 	
4		<ul style="list-style-type: none"> Operation at 50% Maximum Capacity Target Voltage (*) selected to generate a maximum continuous lagging Reactive Power for 30 minutes 	
5		<ul style="list-style-type: none"> Operation at 20% Maximum Capacity Target Voltage (*) selected to generate a maximum continuous leading Reactive Power for 60 minutes. 	
6		<ul style="list-style-type: none"> Operation at 20% Maximum Capacity Target Voltage (*) selected to generate a maximum continuous lagging Reactive Power for 60 minutes. 	
7 (Note 1)		<ul style="list-style-type: none"> Operation at less than 20% Maximum Capacity and unity Power Factor for 5 minutes. This test only applies to systems which do not offer voltage control below 20% of Maximum Capacity 	
8 (Note 2)		<ul style="list-style-type: none"> Operation at the lower of the Minimum Regulating Level or 0% Maximum Capacity and maximum continuous leading Reactive Power for 5 minutes. This test only applies to systems which offer voltage control below 20% and hence establishes actual capability rather than required capability. 	
9 (Note 2)		<ul style="list-style-type: none"> Operation at the lower of the Minimum Regulating Level or 0% Maximum Capacity and maximum continuous lagging Reactive Power for 5 minutes. This test only applies to systems which offer voltage control below 20% and hence establishes actual capability rather than required capability. 	

(*) Target Voltages may need to be changed regularly in order to generate the maximum continuous lagging/leading reactive power for the duration of the test.

Notes

1. If the Power Park Module does not provide voltage control below 20% active power output, then test 7 should be carried out to demonstrate smooth transition to within the required reactive power envelope.

2. If the Power Park Module provides voltage control down to zero active power output, then tests 8 and 9 should be performed

Reactive Capability tests are not normally witnessed by ESO so where a Generator is recording the tests, they should record details such as the HV system voltage and transformer tap position and equipment in service, as applicable, across the test period

For offshore PPMs, for Configuration 1, Schemes 1 and 2 (see Table 5), there is an additional requirement to show that the reactive power at the OGEP is as designed (ECP.A.6.8). where the transformer is tapped and it is shown that the PPM can still provide the reactive power at the OGEP as per design.

Appendix B: Voltage Control Testing

Summary of Requirements

The generic requirements for voltage control are set out in the Grid Code European Connection Conditions with any site-specific variations included in the Bilateral Agreement. This section summarises the key requirements using the generic values included in the Grid Code.

Grid Code ECC.6.3.8 requires provision of a continuously acting automatic voltage control which is stable at all operating points. The point of voltage control is the Grid Entry Point or User System Entry Point if Embedded.

Grid Code ECC Appendix 7 requires:

- ECC.A.7.2.2.2 The voltage set point should be adjustable over a range of +/-5% of nominal with a resolution of better than 0.25%.
- ECC.A.7.2.2.3 The voltage control system should have a reactive slope characteristic which must be adjustable over a range of 2 to 7% with a resolution of 0.5%. The initial setting should be 4%.
- ECC.A.7.2.3.1 The speed of response to a step change should be sufficient to deliver 90% of the reactive capability within 1 second (where a step is large to change reactive power from zero to maximum), with any oscillations damped out, so that the peak-to-peak oscillations in reactive power settle down to less than 5% of the change in steady-state reactive power within a further 5 seconds. The response should start within 0.2 seconds from the application of the step.
- ECC.A.7.2.2.5 The control system should deliver any reactive power output correction due from the voltage operating point deviating from the slope characteristic within 5 seconds.
- ECC.A.7.2.2.6 The Power Park Module must continue to provide voltage control through reactive power modulation within the designed capability limits over the full connection point voltage range +/-10% (ECC.6.1.4) however the full reactive capability (ECC.6.3.2.) is only required to be delivered in line with ECC.6.3.2 and Figure ECC.A.7.2.2(b) or Figure ECC.A.7.2.2(c) if applicable.
- Grid Code Figures ECC.A.7.2.2(b) and ECC.A.7.2.2(c), as applicable, illustrate the operational envelope required.

The Generator must provide ESO with a transfer block diagram illustrating the Power Park Module voltage control scheme and include all associated parameters. This forms part of Schedule 1 of the Data Registration Code and should be included in part 3 of the User Data File Structure (UDFS). The information will enable ESO to review the suitability of the proposed test programme to demonstrate compliance with the Grid Code.

Target Voltage and Slope

The ESO Control Centre issues voltage control instructions to all Balancing Market participants. For Power Park Modules the usual instruction is to alter Target Voltage set point and should be carried out in the usual 2 minutes required for Ancillary Service instructions. The slope may also be varied by control instruction but the Generator has up to a week to complete the change. Slope is usually expected to be set at 4%. The procedures for Voltage Control instructions are included in Grid Code Balancing Code (BC) 2.

Delivery of Reactive Capability Beyond $\pm 5\%$ Voltage

The Grid Code requires a Reactive Capability equivalent to 0.95 power factor usually at the Grid Entry Point or User System Entry Point if Embedded onshore Power Park and at the Offshore Grid Entry Point for Offshore Power Park Modules. For older Power Park Modules, variations from this will be stated in the Bilateral Agreement. Grid Code ECC.6.3.2.4.3 requires that the full Reactive Capability is capable of being delivered for voltages at the Grid Entry Point within $\pm 5\%$ of nominal.

Outside this voltage range the Power Park Module must be capable of continuing to contribute to voltage control by delivering Reactive Power. However, the level of reactive power delivered may be limited by the design of the plant and apparatus. There is no low or high limit on this obligation, plant must continue to provide maximum reactive power within its design limits.

Transient Response

The Grid Code ECC.A.7.2.3.1 sets out a number of criteria for acceptable transient voltage response. The two Figures below illustrate responses from two different control philosophies that would be considered as meeting the Grid Code.

Figure B.1 illustrates a control scheme which employs a constant speed of response.

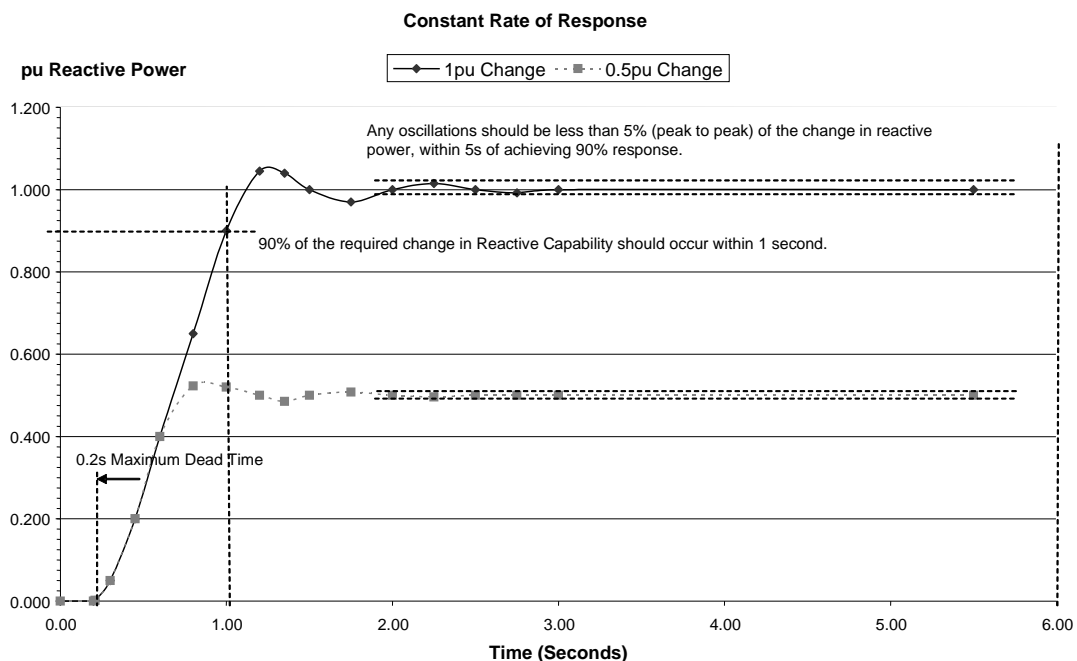

Figure B.1

Figure B.2 shows a control scheme which varies the rate of response proportional to the size of the step change.

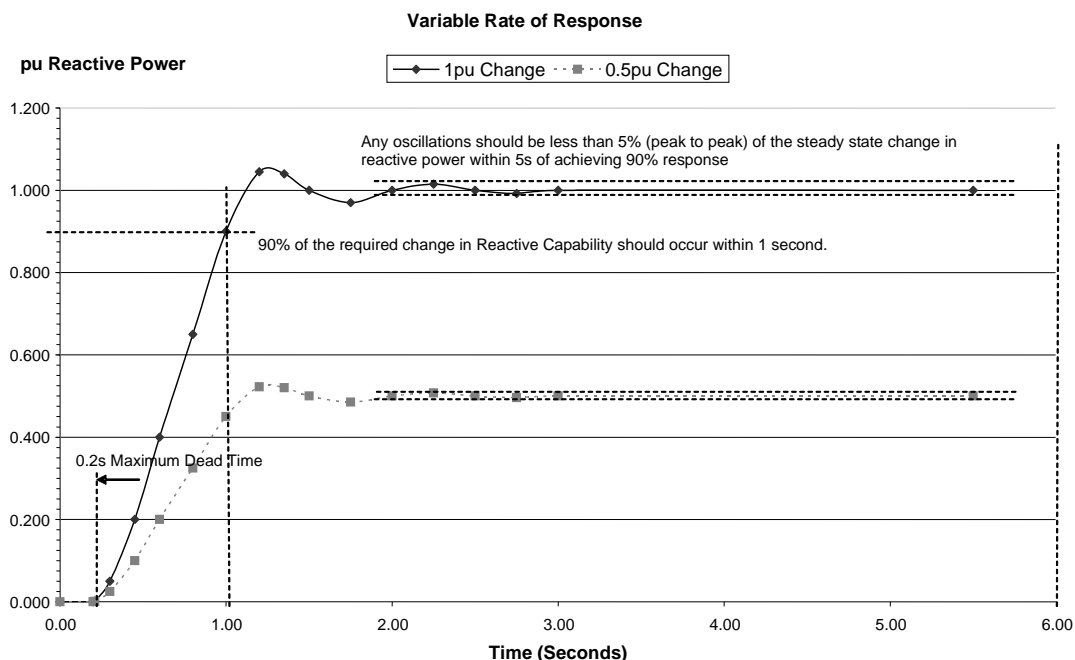

Figure B.2

Both Figures B.1 and B.2 are examples of acceptable responses. Both graphs show the response to two steps, one to initiate a 1pu and the other a 0.5pu change in reactive capability. The graphs show how a variable and constant rate of change both can allow the system to achieve the objective. In both cases the dead time is less than 200ms and 90% of the reactive capability (i.e. 90% of 0.95 power factor at full load or 32.9% Mvar as measured as a proportion of rated power at any other load) is achieved in 1 second. The system settles, with the maximum oscillation in reactive power, in terms of peak-to-peak, limited to less than 5% of the change in steady-state reactive power, within 5 seconds.

Note: The Grid Code states that the reactive response to a change should be “linearly increasing”. For technologies where this may not be appropriate (e.g. capacitor switching), provided the performance is equal to or faster than shown above it will be acceptable.

Variations in Voltage Control Requirements

The Grid Code is continually reviewed by ESO and all Authorised Electricity Operators resulting in a document which is regularly updated. Changes in technical requirements that are considered material to Users are often related to plant Completion Dates. The aim of which is to prevent the need to retrofit older plant with new equipment.

Compliance Test Description

The voltage control tests for a Power Park Module are set out in Grid Code ECP.A.6.5. As described testing should be by tapping of an upstream grid transformer and also by injection to the control system reference.

Where steps can be initiated using network tap changers, the Generator will need to coordinate with the host Transmission or Distribution Network Operator. Consideration should also be given to switching the associated tap changer Automatic Voltage Control (AVC) from auto to manual for the duration of the test.

Suggested Power Park Module Voltage Control Test Procedure

The Module Test should be done when at least 95% of the Power Park Units and any reactive compensation units are in service. Wind conditions (or Tidal Flow or Sunlight etc.) should be such to allow power production from the Module of at least 65% Registered Capacity.

The following generic procedure is provided to assist Generators in drawing up their own site-specific procedures for the ESO Module Voltage Control Tests. ESO may ask for steps to the Voltage Reference greater than those shown below within the guidelines of Engineering Recommendation P28.

Test	Step No	Description of Injection	Notes
		Power Park Module in Voltage Control at Maximum Power Output (>65% Rated MW) and near Unity Power Factor	
V1		<ul style="list-style-type: none"> • Record steady state for 10 seconds • Inject +1% step to Power Park Module Voltage Reference • Hold for at least 10 seconds • Remove injection as a step • Hold for at least 10 seconds 	
V2		<ul style="list-style-type: none"> • Record steady state for 10 seconds • Inject -1% step to Power Park Module Voltage Reference • Hold for at least 10 seconds • Remove injection as a step • Hold for at least 10 seconds 	
V3		<ul style="list-style-type: none"> • Record steady state for 10 seconds • Inject +2% step to Power Park Module Voltage Reference • Hold for at least 10 seconds • Remove injection as a step • Hold for at least 10 seconds 	

V4	<ul style="list-style-type: none"> Record steady state for 10 seconds Inject -2% step to Power Park Module Voltage Reference Hold for at least 10 seconds Remove injection as a step Hold for at least 10 seconds 	
V5	<ul style="list-style-type: none"> Record steady state for 10 seconds Inject +4% step to Power Park Module Voltage Reference Hold for at least 10 seconds Remove injection as a step Hold for at least 10 seconds 	
V6	<ul style="list-style-type: none"> Record steady state for 10 seconds Inject -4% step to Power Park Module Voltage Reference Hold for at least 10 seconds Remove injection as a step Hold for at least 10 seconds 	

Test	Step No	Description of Tapchange	Notes
		Power Park Module in Voltage Control at Maximum Power Output (>65% Rated MW) and near Unity Power Factor	
T1	1	<ul style="list-style-type: none"> Record steady state for 10 seconds Tap up 1 position on external upstream tap changer Hold for at least 10 seconds 	
	2	<ul style="list-style-type: none"> Tap up 1 position on external upstream tap changer i.e. up 2 positions from starting position. Hold for at least 10 seconds 	
	3	<ul style="list-style-type: none"> Tap down 1 position on external upstream tap changer i.e. up 1 positions from starting position. Hold for at least 10 seconds 	
	4	<ul style="list-style-type: none"> Tap down 1 position on external upstream tap changer i.e. at starting position. Hold for at least 10 seconds 	
	5	<ul style="list-style-type: none"> Tap down 1 position on external upstream tap changer i.e. down 1 positions from starting position. Hold for at least 10 seconds 	

	6	<ul style="list-style-type: none"> • Tap down 1 position on external upstream tap changer i.e. down 2 positions from starting position. • Hold for at least 10 seconds 	
	7	<ul style="list-style-type: none"> • Tap up 1 position on external upstream tap changer i.e. down 1 positions from starting position. • Hold for at least 10 seconds 	
	8	<ul style="list-style-type: none"> • Tap up 1 position on external upstream tap changer i.e. return to starting position. • Hold for at least 10 seconds 	

In the case of Power Park Modules that do not provide voltage control down to zero Active Power a test to demonstrate the smooth transition from voltage control mode to unity Power Factor shall be carried out. The Power Park Module voltage setpoint should be altered to produce lagging Reactive Power or absorbing leading Reactive Power at a low Active Power level where voltage control is provided. The Power Park Module Active Power should then be reduced to zero Active Power as a ramp over a short period (60 seconds is suggested)

Where the voltage control system includes either discretely switched shunt capacitors/reactors or bias capacitors to provide part of the reactive capability the test program should demonstrate the performance when these are switched.

Test	Step No	Description of Injection	Notes
		Adjust voltage setpoint to a suitable operating point below switching threshold for shunt device.	
V7	1	<ul style="list-style-type: none"> • Record steady state for 10 seconds • Inject a step to the Power Park Module Voltage Reference of sufficient size and polarity to switch in shunt device. • Hold for at least 10 seconds 	
	2	<ul style="list-style-type: none"> • Remove injection with a step of sufficient size to switch out the switched device • Repeat step 1 immediately (with minimum delay) 	

Where switched devices are normally rotated, devices not required for the particular test should be isolated to prevent their involvement.

Demonstration of Slope Characteristic

The Power Park Module voltage control system is required to follow a steady state slope characteristic. This should be demonstrated by recording voltage at the controlled busbar (usually the Grid Entry Point or User System Entry Point if Embedded) and the reactive power output at the same point over several hours. Plotting the values of Voltage against Reactive Power output should demonstrate the slope characteristic.

Additional Power System Stabiliser Testing

Additional tests are required if a Power System Stabiliser is fitted. Although the fitting of Power System Stabilisers on non-synchronous plant is a rarity, one may be provided within the control system by a manufacturer or ESO may specify the requirement in the Bilateral Agreement. The testing process outlined in this section is based largely on that employed on synchronous plant, which is believed to be comparable. However, Generators should anticipate the possibility that an alternative testing regime may be developed in discussion with ESO.

ESO will not permit PSS commissioning until the tuning methodologies and study results used in any PSS settings proposal have been provided to ESO. A report on the PSS tuning should be provided along with the proposed test procedure in the User Data File Structure (Part 3). Based on the information submitted, ESO will meet with the Generator to discuss and agree the initial PSS settings for commissioning.

The suitability of the tuning of any PSS is checked in both the time and frequency domains. In the time domain, testing is achieved by applying a small voltage step change on a module basis. Comparisons are made between performance with and without the power system stabiliser in service.

For analysis in the frequency domain, a bandwidth-limited (200mHz-3Hz) random noise injection should be made to the Power Park Module voltage reference. The generator should provide a suitable band limited (200mHz-3Hz) noise source to facilitate noise injection testing. The random noise injection will be carried out with and without the PSS in service to demonstrate damping. The PSS gain should be continuously controllable (i.e. not discrete components) during testing.

The suitability of the PSS gain will also be assessed by increasing the gain in stages to 3x the proposed setting.

The tests will be regarded as supporting compliance if:

- The PSS gives improved damping following a step change in voltage.
- Any oscillations are damped out within 2 cycles
- The PSS gives improved damping of frequencies in the band 300mHz – 2Hz.
- The gain margin is adequate if there is no appreciable instability at 3x proposed gain

PSS testing is additional to the Module Voltage Control Tests.

Suggested Power Park Module PSS Test Procedure

The PSS Test should be done when at least 95% of the Power Park Units and any reactive compensation units are in service. Wind conditions should be such to allow power production from the Module of at least 65% Registered Capacity.

The following generic procedure is provided to assist Generators in drawing up their own site-specific procedures for the ESO PSS Tests.

Test	Injection	Notes
	Power Park Module in Voltage Control at Maximum Power Output (>65% Rated MW) and near Unity Power Factor PSS Not in Service	
1	<ul style="list-style-type: none"> Record steady state for 10 seconds Inject +1% step to Power Park Module Voltage Reference and hold for at least 10 seconds Remove step returning Power Park Module Voltage Reference to nominal and hold for at least 10 seconds 	
2	<ul style="list-style-type: none"> Record steady state for 10 seconds Inject +2% step to Power Park Module Voltage Reference and hold for at least 10 seconds Remove step returning Power Park Module Voltage Reference to nominal and hold for at least 10 seconds 	
3	<ul style="list-style-type: none"> Inject band limited (0.2-3Hz) random noise signal into voltage reference and measure frequency spectrum of Real Power. Remove noise injection. 	
	Switch On Power System Stabiliser	
4	<ul style="list-style-type: none"> Record steady state for 10 seconds Inject +1% step to Power Park Module Voltage Reference and hold for at least 10 seconds Remove step returning Power Park Module Voltage Reference to nominal and hold for at least 10 seconds 	
5	<ul style="list-style-type: none"> Record steady state for 10 seconds Inject +2% step to Power Park Module Voltage Reference and hold for at least 10 seconds Remove step returning Power Park Module Voltage Reference to nominal and hold for at least 10 seconds 	
6	<ul style="list-style-type: none"> Inject band limited (0.2-3Hz) random noise signal into voltage reference and measure frequency spectrum of Real Power. Remove noise injection. 	

7	<ul style="list-style-type: none"> • Increase PSS gain at 30second intervals. i.e. x1 – x1.5 – x2 – x2.5 – x3 <p>and observe that the active power oscillations do not get too much</p> <ul style="list-style-type: none"> • Return PSS gain to initial setting 	
	Repeat Module Voltage Control Tests with PSS in service.	

Appendix C: Frequency Control

Summary of Requirements

The National Electricity Transmission System is an island network with no AC connections to mainland Europe. In order to manage the system frequency within the normal operating range 49.5 to 50.5Hz (ECC.6.1.2.1.1) ESO requires generating units and power park modules to be able to continuously modulate their output in relation to frequency across this range. In order to maintain a stable system frequency it is important that response from plant is achieved without undue delay.

The Grid Code sets out Frequency Control requirements in a number of separate places, notably the Glossary & Definitions (GD), European Connection Conditions (ECC) and Balancing Code (BC) 3. This section summarises the key requirements.

The GD of the Grid Code defines Primary, Secondary and High frequency response including the requirement that the response is progressively delivered with increasing time.

ECC.6.3.3.1.1 of the Grid Code specifies that the Power Park Module must be capable of maintaining a minimum level of active power (see Figure ECC.6.3.3(a)) in the frequency range 47Hz to 50.5Hz.

ECC.6.3.7 of the Grid Code specifies the minimum frequency control capability, in particular the frequency control must be:

- Stable over the entire operating range from 47Hz to 52Hz.
- Able to contribute to controlling the frequency on an islanded network to below 52Hz.
- Capable of a frequency droop of between 3 and 5%.
- Capable of providing frequency control against a target set in the range of 49.9Hz and 50.1Hz.
- Have a frequency control dead band of less than ± 0.015 Hz.
- Capable of delivering a minimum level of frequency response.

Grid Code Figure ECC.A.3.1 specifies a minimum requirement for frequency response of 10% of Registered Capacity achievable for Primary, Secondary and High Frequency response. This minimum value is designed to ensure that plant provides a suitable contribution to maintain frequency correction when connected to the system and selected to Frequency Sensitive Mode (FSM) and response capability in excess of 10% is encouraged.

The speed of response is an important criterion and the Grid Code (Figure ECC.A.3.2 and ECC.A.3.3) indicate typical responses from plant with no delay in response from the start of the frequency deviation. Practically there is a permissible deadband and ESO accepts a delay of up to but not exceeding 2 seconds before measurable response is seen from a generating unit in response to a frequency deviation.

BC3 of the Grid Code specifies how plant should be operated and instructed to provide frequency response. The section also sets out the requirements on how all plant should respond to the system frequency rising above 50.4/50.5Hz, by progressively reducing output power.

Details of the tests required for the preliminary and main governor response tests are provided in ECP.A.6.6 but additional guidance is provided in this Appendix including outline test procedures.

Modes of Frequency Control Operation

Balancing Code 3 (BC3) of the Grid Code defines operation in Limited Frequency Sensitive Mode and Frequency Sensitive Mode.

Limited Frequency Sensitive Mode is the default mode used when not instructed by ESO to provide Frequency Response Services. The Power Park Module is not required to provide any immediate decrease in active power output if frequency rises above 50Hz and is only required to maintain active power output in accordance with (ECC 6.3.3). However, the Power Park Module is required to respond to high frequencies above 50.4Hz beyond which the Module must reduce the active power output by a minimum of 2% of output for every 0.1Hz rise above 50.4Hz (see figure C1). Should this cause power output to be forced below Minimum Regulating Level (MRL) then the Power Park Module may disconnect after a time if operation is not sustainable. However, for Power Park Modules, it is acceptable for individual Power Park Units to be disconnected, in order to achieve further power reductions without tripping the module.

In this mode the Power Park Module is not required to provide any increase in active power output if frequency reduces below 50Hz and is only required to maintain active power output in accordance with ECC.6.3.3. However, the Power Park Module is required to respond to low frequencies below 49.5Hz beyond which the Module must increase the active power output by a minimum of 2% of output for every 0.1Hz drop below 49.5Hz (see figure C1). This is not an Ancillary Service, it is a European Connection Condition requirement for all Power Park Module which have this capability. The Power Park Modules are not expected to operate in inefficient manner solely to deliver LFSM-U. Only units with inherited ability are need to comply.

It is important to note that, after GC-0148, there is a new requirement for electrical storage users regarding LFSM-U during active power import mode/charging mode. Please refer to the Grid Code and Guidance Notes for Electrical Storage for further information

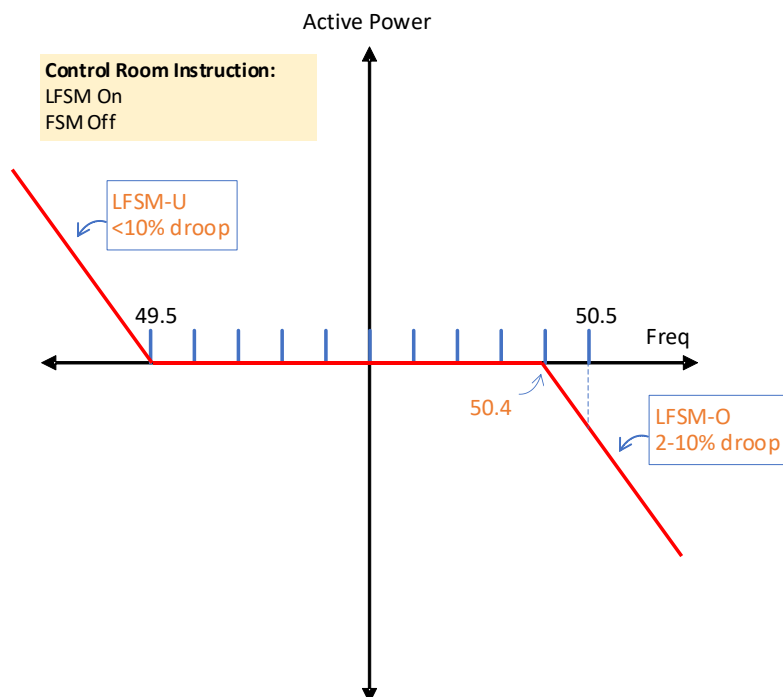

Figure C1 – Limited Frequency Sensitive Mode (LFSM)

Frequency Sensitive Mode is used when control room instructs the user to provide frequency response services. In this mode, the Power Park Module must adjust the active power output in response to any frequency change according to the agreed droop characteristic (between 3-5%). For the purposes of the Mandatory Services Agreement the frequency response performance is measured in terms of the response achieved after a given duration. Between the band of 49.5 Hz and 50.5 Hz, the plant is required to contribute at least 10% of capacity in either direction for a large enough frequency change. It is recommended, however, that the plant's contribution within this band is not restricted.

When system frequency exceeds 50.5Hz, the Power Park Module must further reduce output by a minimum of 2% of output for every 0.1Hz rise above 50.5Hz (see figure C2). Should this cause power the output to be forced below the Minimum Regulating Level (MRL) then the Power Park Module may disconnect from the system after a time if operation is not sustainable. However, for Power Park Modules, it is acceptable for individual Power Park Units to be disconnected, in order to achieve further power reductions without tripping the module.

When system frequency falls below 49.5Hz, it is recommended that the plant further increases its output as per Figure C2, until it reaches maximum available capacity.

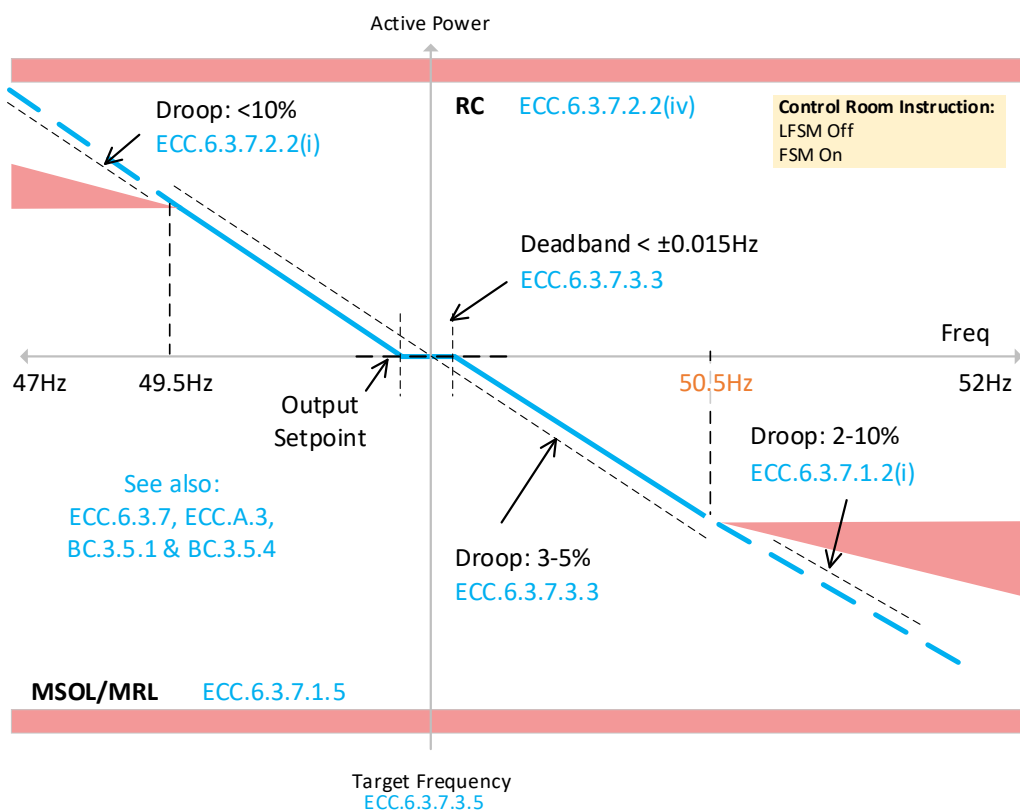

Figure C2 – Frequency Sensitive Mode (FSM)

Target Frequency

All Balancing Market Units (BMUs), irrespective of the plant type (conventional, wind, thermal or CCGT, directly Grid Connected or Embedded), are required to have the facility to set the levels of generator output power and frequency. These are generally known as Target MW and Target Frequency settings.

The ESO Control Centre instructs all Active Balancing Market Unit to operate with the same Target Frequency, normally 50.00 Hz. In order to adjust electric clock time the System Operator may instruct Target Frequency settings of 49.95Hz or 50.05Hz. However, under exceptional circumstances, the instructed settings could be outside this range. The Grid Code requires a minimum setting range from 49.90Hz to 50.10Hz.

This function is tested by stepping the Target Frequency setpoint from the main control point as indicated in ECP.A.6.6.9.

De-load Instructions

System balancing is a separate issue to that of frequency response. A de-load instruction is to a fixed MW value rather than a delta MW value from available power. This removes the majority of the uncertainty associated with the variability of the wind at times when the amount of generation needs to be accurately controlled to allow the system to be safely and securely balanced. This is of course at the expense of a variable low frequency response volume.

Frequency Response from an Intermittent Power Source

Clearly the low frequency response available from a Power Park Module using an Intermittent Power Source is ultimately limited by the available power (referred to as 'Pavail'). It is expected that the low frequency response will be maintained for reducing levels of Power Source unless the 'Pavail' limits the possible response. Figure C3 below illustrates the expected frequency response when 'Pavail' reduces and encroaches upon the available response.

Figure C3 Expected Frequency Response with Reducing Intermittent Power Source

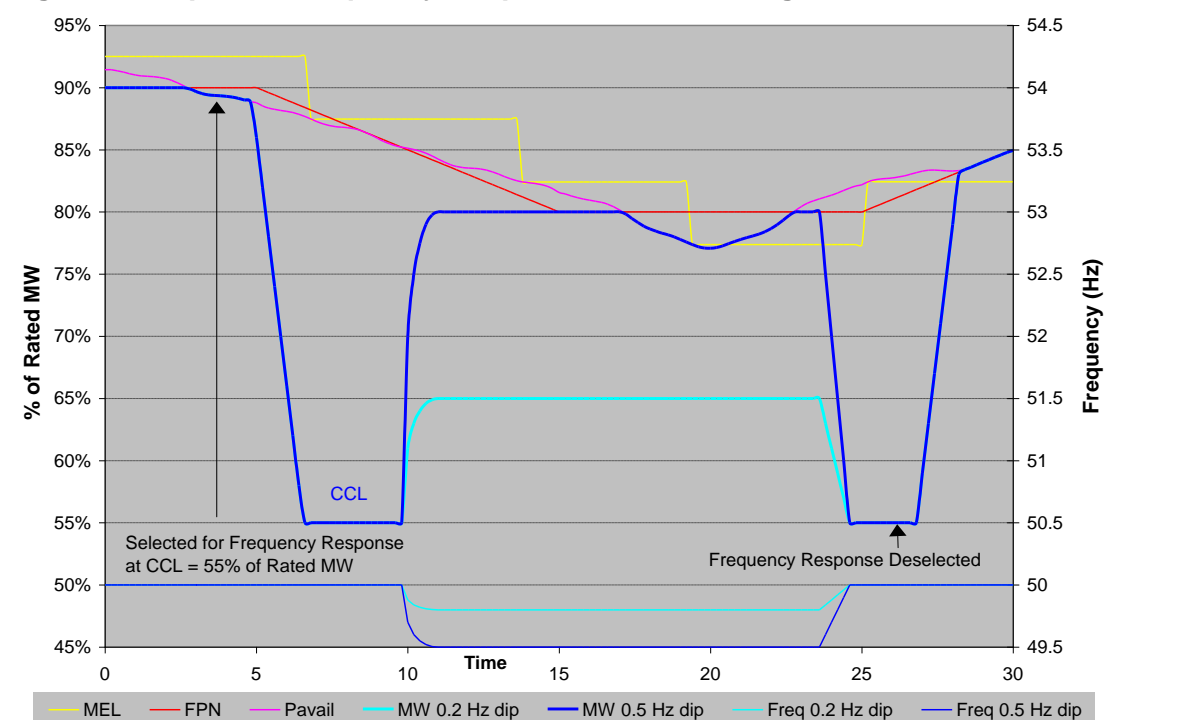

Notes:

The Maximum Export Limit (MEL), is declared to ESO as a Balancing Mechanism parameter effectively equivalent to 'Pavail' which should be updated whenever the 'Pavail' changes by more than 5% or 5MW. The Final Physical Notification (FPN) is the generated power profile submitted to ESO for a ½ hour period before gate closure. Gate closure is one hour ahead of real time. The Capped Committed Level (CCL) is the power level at which a Power Park Module operates when selected for frequency response.

More detailed guidance for manufacturers on how the control system should respond to variations in power setpoint, system frequency and the intermittent power source is included in Appendix E.

Summary of Steady State Load Accuracy Requirements

Grid Code ECC.6.3.9 requires a Power Park Module to be able to control output to a target with an accuracy specified as a standard deviation. With an intermittent power source this requirement applies when operating at power levels below the Maximum Export Level (MEL) which should reflect the availability of the power source.

To demonstrate compliance, the Power Park Module should self-dispatch for 30 minutes at a load significantly below the Maximum Export Level (MEL). The active power output and power available should be recorded with a sampling rate not less than once per minute.

Compliance Testing Requirements

The main objectives of the frequency controller response tests are to establish the plant performance characteristics for compliance with the Grid Code technical requirements (including the validation of plant data/models). They are also required as a measured set of plant response values that will verify the response matrices for the Mandatory Services Agreement.

In order to verify the plant behaviour it is essential that the module is tested in normal operating modes. A frequency disturbance can be simulated by injecting the required frequency variation signals to the frequency reference/feedback summing junction. The results obtained from reducing frequency ramps will be used to verify primary and secondary frequency response. Similarly the results obtained from increasing ramps will be used to verify the high frequency response. Robust and stable response to islanding events can be demonstrated by injecting large and rapid frequency disturbances and observing the response. The recommended tests are shown in Grid Code ECP.A.6.6 Figures 1 and 2.

Typical Frequency Control Test Injection

A frequency injection signal is needed to undertake all frequency related capability tests. Ideally the injected signal will be directly added into the raw frequency feedback as shown in the diagram below. If the Power Park Module frequency control strategy incorporates independent local frequency control at each Power Park Unit then the Generator must identify and implement a method to simultaneously change all relevant frequency control set points or feedback signals to replicate a network frequency change.

Ideally the signal will be software programmable with start/stop initiation via local or remote software interfaces or local digital inputs. Alternatively, the signals should be a $\pm 10V$ analogue input where 1 volt represents 0.2 Hz frequency change.

The above signals should be available at all control nodes within the Power Park controller network, so that if appropriate and applicable, injection can take place on a single Power Park Unit or the central controller.

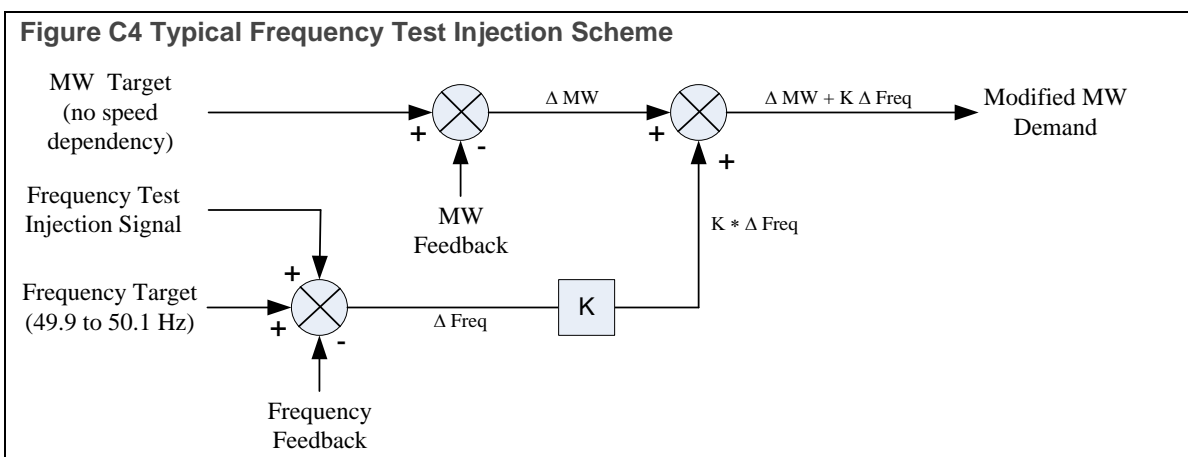

Power Level for Frequency Control Compliance Testing

Power Park Modules using an Intermittent Power Source cannot always provide the Maximum Capacity (MC) indicated to ESO by declaring a lower Maximum Export Limit (MEL). MEL is a dynamic quantity based on the best estimate of available power. MEL can be constrained for many other reasons but for the purposes of this test it should only be constrained as a function of the available power source. Similarly, Stable Export Limit (SEL) is the minimum level that the Power Park Module can provide without tripping under normal Intermittent Power Source variation.

In principle, the maximum capacity available for low frequency response is determined by the 'deload' level from MEL. It is assumed that the low frequency response obtained from the 'deload' points tested above will not be substantially different when the MEL is at other values below MC provided the equivalent 'deload' from MEL is used (i.e. 70% MC would be undertaken at a load point of MEL minus 30% of MC). If this is not the case the Generator must inform ESO and further tests may be required. Similarly, the high frequency response should be similar at all MEL levels unless the response was to encroach upon the SEL.

ECP.A.6.6 sets out the minimum power output and Power Park Unit availability for testing to be carried out. However, ESO reserve the right to request a repeat of the tests at up to 100% of MC if the response is shown to be non-linear or monitoring of frequency response delivery by ESO shows deviations from the submitted frequency response data table.

Pre 70% Tests in Limited Frequency Sensitive Mode for Large Power Park Modules

Preliminary LFSM test applies to large Power Park Modules with a registered capacity of 100MW or more. With large multi-module power stations, there may be a considerable delay before final frequency response testing can be carried out. To control the risk to the system during this period Grid Code ECP.A.6.3.1 requires two tests in Limited Frequency Sensitive mode to be completed before 70%, but at least 50%, of the module has been commissioned.

Preliminary Frequency Response Testing

Past experience has demonstrated that significant delays can occur during testing because of problems associated with the frequency controller setup or frequency injection method. Frequently this results in considerable lost time and additional expense for both parties. Consequently this test has been drawn up and has been shown to help in preventing such situations arising.

Typical injection locations at the frequency controller are shown in Figure C4. In order to avoid the risk of re-testing, it is important that the injection method and the plant control are proved well in advance of the main tests by the Power Park or site contractor. A preliminary test is therefore requested with details given in Grid Code ECP.A.6.6.4 and illustrated below. For all tests, the target frequency selected on the generating plant is that instructed by the ESO Control Centre. This should normally be 50.00 Hz.

With the Power Park Module running with all the turbines in service (100%) and then deload to 80% between Minimum Regulating Level and Maximum Capacity to carry out the following frequency injections should be applied.

Preliminary Frequency Response Tests		
Test No	Frequency Injection	Notes
8	<ul style="list-style-type: none"> Power output at MLP4 Inject -0.50Hz frequency (decrease) over 10 sec Hold for a further 20 sec Inject +0.30Hz frequency (increase) over 30 sec Hold until conditions stabilise Remove the injection signal as a ramp over 10 seconds 	Plant in FSM
13	<ul style="list-style-type: none"> Inject -0.50Hz frequency (decrease) over 10 sec Hold until conditions stabilise Remove the injection signal as a ramp over 10 seconds 	Plant in FSM
14	<ul style="list-style-type: none"> Inject +0.50Hz frequency rise over 10 sec Hold until conditions stabilise Remove the injection signal as a ramp over 10 seconds 	Plant in FSM
H	<ul style="list-style-type: none"> Inject -0.50Hz frequency (decrease) as a step change Hold until conditions stabilise Remove the injection signal as a step change 	Plant in FSM
I	<ul style="list-style-type: none"> Inject +0.50Hz frequency (increase) as a step change Hold until conditions stabilise Remove the injection signal as a step change 	Plant in FSM

The recorded results (e.g. Freq. injected, MW, Pavail, wind speed and control signals) should be sampled at a minimum rate of 1 Hz to allow ESO to assess the plant performance from the initial transients (seconds) to the final steady state conditions (which may typically take 2-3 minutes depending on the plant design). The number of turbines in service should also be stated. Reference power may also be included to help in understanding turbine behaviour.

The preliminary frequency response test results should be sent to ESO for assessment at least two weeks prior to the final witnessed tests.

Frequency Response Testing Sequence

Different loading levels (MPL 6 to MLP 1) for frequency response testing are given in Grid Code ECP.A.6.6. ECP A.6.6 Figure 1 and Figure 2 give the ramps and step frequency injection tests required at these levels. The corresponding test sequence is outlined below with the initial test establishing the maximum steady state output condition of the plant (i.e. MLP 6).

Grid Code ECP.A.6.6 Figure 3 gives the target frequency test requirement to demonstrate from the normal control point, typical load point is MLP4.

1. Establish Maximum Plant Capacity as Loading Point MLP6

- (a) Switch power park controller to manual and raise load demand to confirm the maximum output level at the base settings.
 - (b) Record plant and ambient conditions.
2. **Response Tests at Loading Point MLP6 (Maximum Output)**
- (a) Operate the plant at MLP 6
 - (b) Inject ramp/profiled frequency changes simultaneously into the power park controller (i.e. Tests 1-4 in ECP.A.6.6 Figure 1) and record plant responses.
 - (c) Conduct test BC1 – BC4 as shown in ECP.A.6.6 Figure 2 to establish the deloading capability as could occur under system islanding or system split conditions. Please note tests BC1 & BC2 are FSM whilst tests BC3 & BC4 are LFSM.
 - (d) Conduct test O as shown in ECP.A.6.6 Figure 2 to establish the power park controller, and step response characteristics for power park controller modelling purposes.
 - (e) Conduct test L as shown in ECP.A.6.6. Figure 2 and record plant responses
3. **Response Tests at Loading Point MLP5 (90% MEL)**
- (a) Operate the plant at MLP5.
 - (b) Conduct tests 5-7 as shown in ECP.A.6.6 Figure 1 and record plant responses.
 - (c) Conduct test A as shown in ECP.A.6.6 Figure 2 to establish the robustness of the control system under simulated extreme disturbances (as could occur under system islanding or system split conditions).
4. **Response Tests at Loading Point MLP4 (80% MEL)**
- (a) Operate the plant at loading point 4 (MLP 4).
 - (b) Conduct tests 8-14 as shown in ECP.A.6.6 Figure 1 and record plant responses.
 - (c) Conduct tests D - I as shown in ECP.A.6.6 Figure 2 to establish the power park controller, and step response characteristics for power park controller modelling purposes.
 - (d) Conduct test J as shown in Figure 2 to establish the robustness of the control system under simulated extreme disturbances (e.g., system islanding or system split).
 - (e) Conduct test M as shown in ECP.A.6.6. Figure 2 and record plant responses
 - (f) Operate the plant in Limited Frequency Sensitive Mode (MLP4 LFSM), conduct test BC5/BC6 as shown in ECP.A.6.6 Figure 2 to demonstrate LFSM-O and LFSM-U capability.
 - (g) Conduct test N as shown in ECP.A.6.6. Figure 2 and record plant responses
5. **Response Tests at Load Point MLP3 (MRL+0.6 x (MEL – MRL))**
- (a) Operate the plant at MLP3.
 - (b) Conduct tests 15 to 17 as shown in ECP.A.6.6 Figure 1 and record plant responses.
6. **Response Tests at Load Point MLP2 (MRL+0.3 X (MEL – MRL) or MSOL)**
- (a) Operate the plant at MG.
 - (b) Conduct tests 18 - 22 as shown in ECP.A.6.6 Figure 1 and record plant responses.
 - (c) Conduct tests P and Q as shown in ECP.A.6.6. Figure 2 and record plant responses.
7. **Response Tests at Designed Minimum Operating Level MLP1 (MRL)**
- (a) Operate the plant at MRL.
 - (b) Conduct tests 23 - 26 as shown in ECP.A.6.6 Figure 1 and record plant responses.

- (c) Conduct test K as shown in ECP.A.6.6 Figure 2 to establish the step response characteristics for power park controller modelling purposes.

Generic Frequency Response Test Procedure

Since the governor response tests described above are to be arranged and conducted by the Generator, it is their responsibility to propose a test programme to suit their site-specific requirements. A typical example of the test procedure based on ECP.A.6.6 Figures 1 and 2 is given below. This procedure is required to be submitted to ESO for approval before an ION is issued.

Initial Checks on Maximum Plant Capability at MLP6, Plant in LFSM	
Step	Actions
1	Record plant MLP 6 condition including levels for module MW output, ambient wind speed, and direction.
2	Change power park controller to manual and increase active power output to maximum.
3	Record plant conditions when plant is Stabilised.
4	Reset power park controller to normal operating mode and allow MLP 6 condition to be established

Injection Tests at MLP6, Plant in FSM			
Test No.	Action	Frequency Injection	Notes
1	<ul style="list-style-type: none"> Inject +0.10Hz frequency rise over 10 sec Hold until conditions stabilise³ Remove the injection signal over 10 sec⁴ Hold until conditions stabilise at MLP 6 	+0.10Hz -0.10Hz	
2	<ul style="list-style-type: none"> Inject -0.20Hz frequency fall over 10 sec Hold until conditions stabilise³ Remove the injection signal over 10 sec Hold until conditions stabilise at MLP 6 	-0.20Hz +0.20Hz	
3	<ul style="list-style-type: none"> Inject +0.20Hz frequency rise over 10 sec Hold until conditions stabilise³ Remove the injection signal over 10 sec⁴ Hold until conditions stabilise at MLP 6 	+0.20Hz -0.20Hz	

4	<ul style="list-style-type: none"> Inject +0.50Hz frequency rise over 10 sec Hold until conditions stabilise³ Remove the injection signal over 10 sec⁴ Hold until conditions stabilise at MLP 6 	+0.50Hz -0.50Hz	
BC1	<p><u>Plant in FSM</u></p> <ul style="list-style-type: none"> Inject +2.0* Hz frequency rise over 1 sec Hold until conditions stabilise³ Remove the injection signal over 1 sec⁴ Hold until conditions stabilise at MLP 6 	+2.0 Hz * -2.0 Hz	Part of functionality test for islanding ECC.6.3.7
O	<p><u>Plant in FSM</u></p> <ul style="list-style-type: none"> Inject +0.5 Hz frequency rise as a step change Hold until conditions stabilise³ Remove the injection signal as a step⁴ Hold until conditions stabilise at MLP 6 	+0.5 Hz -0.5 Hz	To assess step response characteristics of plant
BC2	<p><u>Plant in FSM</u></p> <ul style="list-style-type: none"> Inject +0.6 Hz frequency rise over 30 sec Hold until conditions stabilise³ Remove the injection signal ⁴ Hold until conditions stabilise at MLP 6 	+0.6 Hz -0.6 Hz	Part of functionality test for BC.3.7.1
L	<p><u>Plant in FSM</u></p> <ul style="list-style-type: none"> Record normal system variation in frequency and active power of the generating unit over at least 10 minutes. Load setpoint at maximum. 	No injection	Check for live frequency measurement See Note 1
Switch to Limited Frequency Sensitive Mode			
BC3	<p><u>Plant in LFSM</u></p> <ul style="list-style-type: none"> Inject +2.0* Hz frequency rise over 1 sec Hold until conditions stabilise³ Remove the injection signal ⁴ Hold until conditions stabilise at MLP 6 	+2.0 Hz -2.0 Hz	Part of functionality test for islanding CC.6.3.7 (c)(i)
BC4	<p><u>Plant in LFSM</u></p> <ul style="list-style-type: none"> Inject +0.6 Hz frequency rise over 30 sec Hold until conditions stabilise³ Remove the injection signal ⁴ Hold until conditions stabilise at MLP 6 	+0.6 Hz -0.6 Hz	Part of functionality test for BC.3.7.2

* This will generally be +2.0Hz unless an injection of this size causes a reduction in plant output that takes the operating point below Minimum Regulating Level in which case an appropriate injection should be calculated in accordance with the following:

For example 0.9Hz is needed to take an initial output 65% to a final output of 20%. Calculation of the injected step should be as shown in the example given below

Initial Output	65%
Minimum Regulating Level	20%
Frequency Controller Droop	4%
Frequency to be injected = $(0.65-0.20) \times 0.04 \times 50 =$	0.9Hz

Injection Tests at MLP 5, Plant in FSM			
5	<ul style="list-style-type: none"> Inject -0.50Hz frequency fall over 10 sec Hold for 20 sec 	-0.50Hz	
	<ul style="list-style-type: none"> Inject 0.30Hz frequency rise over 30 sec Hold until conditions stabilise³ 	+0.30Hz	
	<ul style="list-style-type: none"> Remove the injection signal over 10 sec⁴ Hold until conditions stabilise at MLP 5 	+0.20Hz	
6	<ul style="list-style-type: none"> Inject -0.20Hz frequency fall over 10 sec Hold until conditions stabilise³ 	-0.20Hz	
	<ul style="list-style-type: none"> Remove the injection signal over 10 sec⁴ Hold until conditions stabilise at MLP 5 	+0.20Hz	
7	<ul style="list-style-type: none"> Inject +0.50Hz frequency rise over 10 sec Hold until conditions stabilise³ 	+0.50Hz	
	<ul style="list-style-type: none"> Remove the injection signal over 10 sec⁴ Hold until conditions stabilise at MLP 5 	-0.50Hz	
A	<ul style="list-style-type: none"> Inject -0.5Hz frequency step Hold until condition stabilise Remove the step injection ⁴ Hold until conditions stabilise at MLP 5 	-2.0Hz +2.0Hz	To assess plant performance under islanding and system split Conditions

Injection Tests at MLP 4, Plant in FSM			
8	<ul style="list-style-type: none"> Inject -0.50Hz frequency fall over 10 sec Hold for 20 sec 	-0.50Hz	
	<ul style="list-style-type: none"> Inject +0.30Hz frequency rise over 30 sec Hold until conditions stabilise³ 	+0.30Hz	

	<ul style="list-style-type: none"> Remove the injection signal over 10 sec⁴ Hold until conditions stabilise at MLP 4 	+0.20Hz	
9	<ul style="list-style-type: none"> Inject -0.10Hz frequency fall over 10 sec Hold until conditions stabilise³ Remove the injection signal over 10 sec⁴ Hold until conditions stabilise at MLP 4 	-0.10Hz +0.10Hz	
10	<ul style="list-style-type: none"> Inject 0.10Hz frequency rise over 10 sec Hold until conditions stabilise³ Remove the injection signal over 10 sec⁴ Hold until conditions stabilise at MLP 4 	+0.10Hz -0.10Hz	
11	<ul style="list-style-type: none"> Inject -0.20Hz frequency fall over 10 sec Hold until conditions stabilise³ Remove the injection signal over 10 sec⁴ Hold until conditions stabilise at MLP 4 	-0.20Hz +0.20Hz	
12	<ul style="list-style-type: none"> Inject 0.20Hz frequency rise over 10 sec Hold until conditions stabilise³ Remove the injection signal over 10 sec⁴ Hold until conditions stabilise at MLP 4 	+0.20Hz -0.20Hz	
13	<ul style="list-style-type: none"> Inject -0.50Hz frequency fall over 10 sec Hold until conditions stabilise³ Remove the injection signal over 10 sec⁴ Hold until conditions stabilise at MLP 4 	-0.50Hz +0.50Hz	
14	<ul style="list-style-type: none"> Inject 0.50Hz frequency rise over 10 sec Hold until conditions stabilise³ Remove the injection signal over 10 sec⁴ Hold until conditions stabilise at MLP 4 	+0.50Hz -0.50Hz	
D	<ul style="list-style-type: none"> Inject -0.02Hz frequency fall as a step change Hold until conditions stabilise Remove the injection signal⁴ Hold until conditions stabilise at MLP 4 	-0.02Hz +0.02Hz	To assess the governor deadband
E	<ul style="list-style-type: none"> Inject 0.02Hz frequency rise as a step change Hold until conditions stabilise Remove the injection signal⁴ Hold until conditions stabilise at MLP 4 	+0.02Hz -0.02Hz	To assess the governor deadband
F	<ul style="list-style-type: none"> Inject -0.20Hz frequency fall as a step change 	-0.20Hz	To assess step response

	<ul style="list-style-type: none"> Hold until conditions stabilise Remove the injection signal ⁴ Hold until conditions stabilise at MLP 4 	+0.20Hz	characteristics of plant
G	<ul style="list-style-type: none"> Inject 0.20Hz frequency rise as a step change Hold until conditions stabilise Remove the injection signal ⁴ Hold until conditions stabilise at MLP 4 	+0.20Hz -0.20Hz	To assess step response characteristics of plant
H	<ul style="list-style-type: none"> Inject -0.50Hz frequency fall as a step change Hold until conditions stabilise Remove the injection signal ⁴ Hold until conditions stabilise at MLP 4 	-0.50Hz +0.50Hz	To assess step response characteristics of plant
I	<ul style="list-style-type: none"> Inject 0.50Hz frequency rise as a step change Hold until conditions stabilise at MLP 4 Remove the injection signal ⁴ Hold until conditions stabilise at MLP 4 	+0.50Hz -0.50Hz	To assess step response characteristics of plant
J	<ul style="list-style-type: none"> Inject 1.0Hz/sec frequency fall over 2 sec Hold for 30 sec Remove the injection signal ⁴ Hold until conditions stabilise at MLP4 	-2.0Hz +2.0Hz	To assess plant performance under islanding and system split conditions
M	<ul style="list-style-type: none"> Record normal system variation in frequency and active power of the generating unit over at least 10 minutes 	No injection	See Note 1
	<u>Plant in LFSM</u>		
BC5	<ul style="list-style-type: none"> Inject -0.50Hz frequency fall over 30 sec Hold until conditions stabilise Remove the injection signal over 30 sec⁴ Hold until conditions stabilise at MLP 4 	-0.5Hz +0.5Hz	To demonstrate LFSM-U capability.
BC6	<ul style="list-style-type: none"> Inject -1.0Hz frequency fall over 30 sec Hold until conditions stabilise Remove the injection signal over 30 sec⁴ Hold until conditions stabilise at MLP 4 	-1.0Hz +1.0Hz	To demonstrate LFSM-U capability.
N	<ul style="list-style-type: none"> Record normal system variation in frequency and active power of the generating unit over at least 10 minutes Switch plant to Frequency Sensitive Mode 	No injection	See Note 2

Injection Tests at MLP 3, Plant in FSM			
15	<ul style="list-style-type: none"> Inject -0.50Hz frequency fall over 10 sec Hold for 20 sec Inject 0.30Hz frequency rise over 30 sec Hold until conditions stabilise³ Remove the injection signal over 10 sec⁴ Hold until conditions stabilise at MLP 3 	-0.50Hz	
		+0.30Hz	
		+0.20Hz	
16	<ul style="list-style-type: none"> Inject 0.50Hz frequency rise over 10 sec Hold until conditions stabilise³ Remove the injection signal over 10 sec⁴ Hold until conditions stabilise at MLP 3 	+0.50Hz	
		-0.50Hz	
17	<ul style="list-style-type: none"> Inject -0.80Hz frequency fall over 10 sec Hold for 20 sec. Inject 0.30Hz frequency rise over 30 sec Hold until conditions stabilise³ Remove the injection signal over 10 sec⁴ Hold until conditions stabilise at MLP 3 	-0.80Hz	
		+0.30Hz	
		+0.50Hz	

Injection Tests at MLP2, Plant in FSM			
18	<ul style="list-style-type: none"> Inject -0.50Hz frequency fall over 10 sec Hold for 20 sec Inject 0.30Hz frequency rise over 30 sec Hold until conditions stabilise³ Remove the injection signal over 10 sec⁴ Hold until conditions stabilise at MLP 2 	-0.50Hz	
		+0.30Hz	
		+0.20Hz	
19	<ul style="list-style-type: none"> Inject -0.20Hz frequency fall over 10 sec Hold until conditions stabilise³ Remove the injection signal over 10 sec⁴ Hold until conditions stabilise at MLP 2 	-0.20Hz	
		+0.20Hz	
20	<ul style="list-style-type: none"> Inject 0.20Hz frequency rise over 10 sec Hold until conditions stabilise³ Remove the injection signal over 10 sec⁴ Hold until conditions stabilise at MLP 2 	+0.20Hz	
		-0.20Hz	

21	<ul style="list-style-type: none"> Inject -0.50Hz frequency fall over 10 sec Hold until conditions stabilise³ Remove the injection signal over 10 sec⁴ Hold until conditions stabilise at MLP 2 	-0.50Hz +0.50Hz	
22	<ul style="list-style-type: none"> Inject -0.80Hz frequency fall over 10 sec Hold for 20 sec Inject 0.30Hz frequency rise over 30 sec Hold until conditions stabilise³ Remove the injection signal over 10 sec⁴ Hold until conditions stabilise at MLP 2 	-0.80Hz +0.30Hz +0.50Hz	
P	<ul style="list-style-type: none"> Inject -0.50Hz frequency fall as a step change Hold until conditions stabilise Remove the injection signal ⁴ Hold until conditions stabilise at MLP 2 	-0.50Hz +0.50Hz	To assess step response characteristics of plant
Q	<ul style="list-style-type: none"> Inject 0.50Hz frequency rise as a step change Hold until conditions stabilise Remove the injection signal ⁴ Hold until conditions stabilise at MLP 2 	+0.50Hz -0.50Hz	To assess step response characteristics of plant

Injection Tests at MLP 1, Plant in FSM

23	<ul style="list-style-type: none"> Inject -0.50Hz frequency fall over 10 sec Hold for 20 sec Inject 0.30Hz frequency rise over 30 sec Hold until conditions stabilise³ Remove the injection signal over 10 sec⁴ Hold until conditions stabilise at MLP 1 	-0.50Hz +0.30Hz +0.20Hz	
24	<ul style="list-style-type: none"> Inject -0.20Hz frequency fall over 10 sec Hold until conditions stabilise³ Remove the injection signal over 10 sec⁴ Hold until conditions stabilise at MLP 1 	-0.20Hz +0.20Hz	
25	<ul style="list-style-type: none"> Inject 0.20Hz frequency rise over 10 sec Hold until conditions stabilise³ Remove the injection signal over 10 sec⁴ Hold until conditions stabilise at MLP 1 	+0.20Hz -0.20Hz	

26	<ul style="list-style-type: none"> Inject -0.80Hz frequency fall over 10 sec Hold for 20 sec 	-0.80Hz	
	<ul style="list-style-type: none"> Inject 0.30Hz frequency rise over 30 sec Hold until conditions stabilise³ 	+0.30Hz	
	<ul style="list-style-type: none"> Remove the injection signal over 10 sec⁴ Hold until conditions stabilise at MLP 1 	+0.50Hz	
K	<ul style="list-style-type: none"> Inject -0.5Hz frequency fall as a step change Hold until conditions stabilise 	-0.5Hz	To assess plant performance under islanding and system split conditions
	<ul style="list-style-type: none"> Remove the injection signal ⁴ Hold until conditions stabilise at MLP 1 	+0.5Hz	

Note 1

Tests L and M in ECP.A.6.6. Figure 2 should be conducted if the system frequency feedback signal is replaced by the injection signal rather than the injection signal being added to the system frequency signal. The tests simply consist of monitoring the Power Park Module in Frequency Sensitive Mode during normal system frequency variations without applying any injection.

Note 2

Test N in figure 2 should be conducted in all cases. All three tests should be conducted for a period of at least 10 minutes.

Note 3

Hold period should be maintained until the Active Power (MW) output of the Power Park Module has stabilised or 90 seconds, whichever is longer.

Note 4

All frequency response test injections should be removed over the same timescale for which they were applied unless otherwise specified.

Control Requirements that may be witnessed

During attendance on site for witness testing of frequency response, ESO may request that the Generator alters the Target Frequency setpoint from the Generators Control Room as an indication of controllability. This may be combined with tests M in ECP.A.6.6 Figure 2. The following test procedure indicates the steps of target frequency required in ECP.A.6.6.9.

Target Frequency Tests at MLP 4, Plant in FSM			
TF	<ul style="list-style-type: none"> Operate at MLP4 for 60 seconds Alter Target Frequency to 50.05Hz 	50.05Hz	
	<ul style="list-style-type: none"> Hold for 30 seconds or until conditions stabilise Alter Target Frequency to 50.10Hz 	50.10Hz	

	<ul style="list-style-type: none"> • Hold for 30 seconds or until conditions stabilise 	50.00Hz	
	<ul style="list-style-type: none"> • Alter Target Frequency to 50.00Hz 		
	<ul style="list-style-type: none"> • Hold for 30 seconds or until conditions stabilise 	49.95Hz	
	<ul style="list-style-type: none"> • Alter Target Frequency to 49.95Hz 		
	<ul style="list-style-type: none"> • Hold for 30 seconds or until conditions stabilise 	49.90Hz	
	<ul style="list-style-type: none"> • Alter Target Frequency to 49.90Hz 		
	<ul style="list-style-type: none"> • Hold for 30 seconds or until conditions stabilise 	50.00Hz	
	<ul style="list-style-type: none"> • Alter Target Frequency to 50.00Hz 		
<ul style="list-style-type: none"> • Hold for 30 seconds or until conditions stabilise 			

Appendix D: Power Park Unit Performance Registration and Fault Ride Through

Scope

This Appendix is intended to provide guidance for Power Park Unit Manufacturers rather than Generators on the direct submission of information and data to ESO to assist in the demonstration of compliance.

Generic Power Park Unit Type Validation

Power Park Modules generally comprise of a large number of identical Power Park Units. Within manufacturing tolerances, the performance of a specific Power Park Unit type is normally reasonably constant from unit to unit and at whichever site they are installed. It is therefore possible to register various aspects of this performance and the associated data once, and then reference this data for some or all of the sites which use this particular type of equipment. The Grid Code recognises this by the provision of Manufacturer's Data and Performance Reports in ECP.11. The aim is to reduce the volume of work required by Users, Power Park Unit manufacturers and ESO in assessing the same information at different sites.

In addition, the Manufacturer's Data and Performance Reports can provide a route for detailed data that Power Park Unit manufacturers regard as commercially sensitive to be sent directly to ESO without publication to the User(s).

Background to Generic Power Park Unit Type Validation

To implement the provision of CECP.11 ESO has developed the generic compliance process which allows manufacturers to work directly with ESO in order to exchange information and evidence of compliance without data passing through a project chain. Figures D1 to D3 illustrate the differences in the two processes. Figure D1 demonstrates the conventional process where the data flow is always via the power station or power park developer.



Figure D1 – The conventional compliance process data route.

Figure D2 shows the one time process to fill the generator equipment ‘type’ register. It may be that information only comes from the manufacturer although a developer may be involved by providing site test opportunities. The data will comprise of a report on one or more of the aspects outlined below.

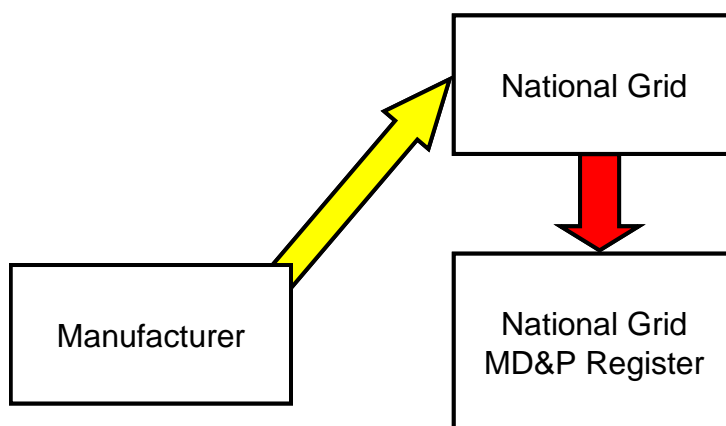

Figure D2 – The Register of Manufacturer’s Data & Performance Report is filled with a selection of generic data.

Figure D3 illustrates the process for referencing and using ‘generic’ data. Each project can, where appropriate, reference information held in the ESO generator equipment Register of Manufacturer’s Data & Performance Report substituting information that they are required to submit before connecting to the National Electricity Transmission System and in lieu of some aspects of Grid Code testing. Developers will not have access to this information from ESO and the only requirement is to obtain the correct reference from the manufacturer. If no relevant or insufficient data is held in the Register of Manufacturer’s Data & Performance Report then the data must be provided in full by the developer.

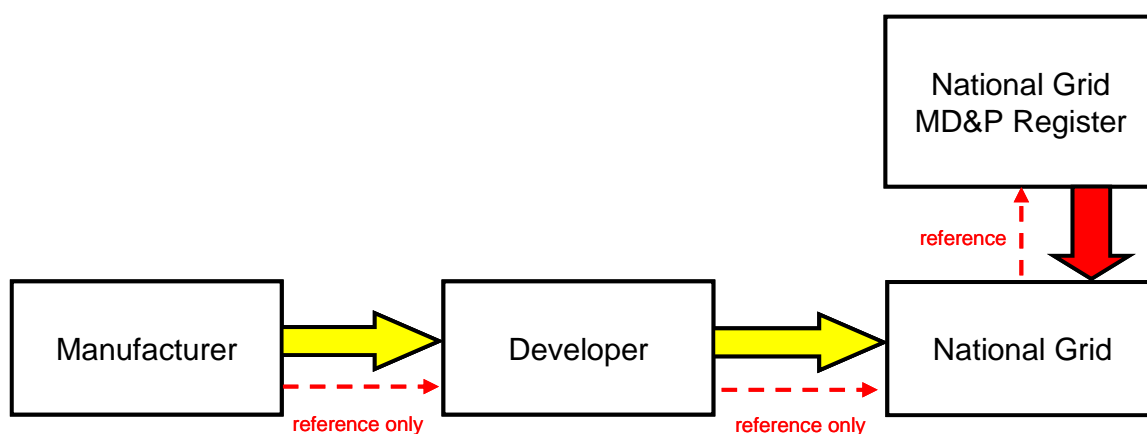

Figure D3 – The generic data (red arrow) is referenced but cannot be seen by the developer. There will still be some requirement for site specific data (yellow arrow)

Confidentiality Provisions

Data submitted by developers under the Data Registration Code (Grid Code) is protected by the confidentiality agreement contained in the Connection and Use of System Code (CUSC) and System Operator Transmission Owner Code (STC). This does not explicitly cover generic data sent from manufacturers directly to ESO as it does not necessarily relate to a specific project. It is therefore recommended for manufacturers to sign a confidentiality agreement with ESO prior to any exchange of information.

Please note that ESO cannot sign individual manufacturer's confidentiality agreements as they may not cover the following aspects which are necessary to participate in the generic compliance process.

The following aspects are typical of the provisions of a confidentiality agreement between a manufacturer and ESO in relation to registering generic Manufacturers Data and Performance Reports information with ESO.

This agreement has been written to reflect the confidentiality provisions in the CUSC which deals with the confidentiality of data as between ESO and Developers generally. ESO will NOT however be permitted to release this 'generic' information back to developers (with the exception of the generic information document reference as originally submitted) which is unlike data submissions received through the normal project chain.

- Some aspects of data must be passed to other Transmission System Operators and Owners in GB for system operation and design reasons as per the System Operator and Transmission Owner Code (STC).
- The 'Purpose' as defined in the Agreement reflects the purposes for which ESO do (and are permitted under the CUSC) to use information provided to ESO by developers through the normal project chain.
- The agreement is subject to the laws of England & Wales because the entire framework within which this data will be used is structured around English law and if the data was directly provided by a Developer it would be subject to English law.
- Company Policy requires ESO business areas to adopt information and records management procedures that comply with all relevant legal requirements and are consistent with best practice as applied to their business needs. The records management procedure for this area provides that this data must be kept for 7 years after the data is last used. This therefore requires that the data should be kept for a period equating to the life of any plant it refers to plus a period of 7 years. This is in line with normal project data submissions direct from developers.
- ESO may pass back information (e.g., computer models) to the manufacturer but does not accept any liability in respect of its accuracy.

If this agreement is not signed then the standard Grid Code data requirements apply and all data will need to be provided through the project chain. Failure to supply adequate data by either of these methods will result in non-compliance by the developer with the GB Grid Code and possible disconnection or denial of permission to connect to the GB transmission system.

Areas Suitable for Manufacturer's Data & Performance Report

The Grid Code (ECP.11.2) allows the Fault Ride Through capability and the Power Park Module mathematical model to be covered by a Manufacturer's Data & Performance Report. The manufacturer may choose to complete one or both of the above mentioned areas. In each case the manufacturer should submit a detailed report to ESO for approval and consequent submission into the Manufacturer's Data & Performance Report Register.

To achieve registration for the item Fault Ride Through capability a series of tests and data submissions will be developed to demonstrate the performance characteristics of a single Power Park Unit. Details of these tests and submissions are to be agreed between the Power Park Unit manufacturer and ESO. ESO may wish to witness some or all of these tests.

To achieve registration for a Power Park Module mathematical model, ESO and the Power Park Unit manufacturer will need to agree a series of simulations and data submissions in relation to a specific mathematical model of the Power Park Unit and associated control systems in line with the requirements outlined in PC.A.5.4.2. In addition, the performance of this model should be validated against test results including faults, voltage steps and frequency changes as is deemed to be appropriate by ESO.

Submitting Data into the Register of Manufacturer's Data & Performance Report

Manufacturers considering registration should talk to ESO early in their planning stage.

In order to be considered for registration, the Power Park Unit manufacturer should submit a report to ESO outlining the details and results as appropriate for its consideration. Each report should have an appropriate reference including manufacturer name, type of report (e.g. Fault Ride Through etc.), Power Park Unit type, date and report version number to permit referencing in future projects or for updates.

ESO will, following submission of all required reports and data, confirm to the Power Park Unit manufacturer in writing whether the Power Park Unit report has been accepted. Once accepted the Manufacturer's Data & Performance Report Register status will be updated to indicate the acceptance in respect of the relevant Grid Code requirement.

Summary of Grid Code Fault Ride Through Requirements

This section summarises the requirements for all new Power Park Modules contained in ECC.6.3.15 of the Grid Code.

The Grid Code 'fault ride through' requirements apply to all faults on the 275kV or 400kV National Electricity Transmission System. The requirements vary depending on the type of fault and the Supergrid voltage profile (duration of fault or voltage dip).

These requirements can be conveniently referred to in the context of two separate fault modes, A & B, which are respectively covered by ECC.6.3.15.1 – ECC.6.3.15.8 (Mode A) and ECC.6.3.15.9 (Mode B) of the Grid Code.

'Mode A' Requirements - first 140msec of a fault

'Mode A' refers to the first 140msec of three-phase, phase to phase, two-phase to earth or single-phase to earth faults.

Throughout this period the Power Park Module is required to remain transiently stable and connected for all Supergrid phase voltages down to a minimum of 0%. It should also generate the maximum possible reactive current without exceeding the transient rating limit of the Power Park Module or any constituent element.

Within 0.5 seconds, following fault clearance and restoration of the Supergrid voltage to at least 90% of nominal, the Power Park Module must restore the Active Power output to at least 90% of the level available immediately before the fault.

It is anticipated that in achieving this response the control system may be under damped. This will be considered acceptable provided any oscillations decay in a suitably short period and that whilst the oscillations are present the average Active power delivered corresponds with the levels required were the oscillations not present.

Although the voltage will begin to recover upon fault clearance (within 140msec) it may not necessarily reach 90% voltage within the 140msec period as illustrated in the Appendix of the European Connection Conditions (ECC.A.4A.2). If the Supergrid Voltage has not restored to at least 90% within 140msec then the remaining fault period can be assumed to have a balanced retained voltage and that 'Mode B' requirements will then apply for the remainder of the fault period.

GC-0141 has added the requirement that the Power Park Module stay connected and remain stable for up to 30min, following a fault-ride-through event.

'Mode B' Requirements - fault period beyond the first 140msec

'Mode B' refers to a period of balanced voltage reduction due to power system transients caused by remote faults or the period following clearance of Supergrid faults where the voltage remains reduced for a period.

Throughout this period the Power Park Module is required to remain transiently stable and connected. It must maintain Active Power at least in proportion to the retained balanced Supergrid Voltage and generate the maximum possible reactive current without exceeding the transient rating limit of the Power Park Module or any constituent element.

Within 1 second, following fault clearance and restoration of the Supergrid voltage to at least 90% of nominal, the Power Park Module must restore the Active Power output to at least 90% of the level available immediately before the fault. Once again, appropriately damped active power oscillations shall be acceptable provided the total energy delivered during the period of the oscillation shall be 90% or more.

The worst case duration for which Mode B requirements apply can be calculated by taking the lowest voltage occurring after the first 140msec and finding where it intersects the profile illustrated in Figure ECC.6.3.15.9(b).

GC-0141 has added the requirement that the Power Park Module stay connected and remain stable for up to 30min, following a fault-ride-through event.

Fast Fault Current Injection

The requirement applies for Type B, Type C and Type D Power Park Modules and HVDC equipment. The principles and details of the requirement are set out in ECC.6.3.16 and ECC.A.4.A of the Grid Code. Simulations and type tests will be used to confirm the status of FFCl compliance. For any further guidance please contact the Connection Compliance team.

The Power Park Module or HVDC System Owner shall supply time series simulation study results to demonstrate the capability of HVDC Equipment and Power Park Modules and OTSUA to meet ECC.6.3.16 by submission of a report described in ECP.A.3.5. The simulations are encouraged to be performed using EMT software (PC.A.5.4 and PC.A.9).

Requirements for Induction Generators

Induction Generators and Doubly Fed Induction Generators typically deliver large amounts of lagging reactive current on application of a fault, which is frequently followed by the delivery of leading current. Thereafter, the current level is dependent upon the technology used and its configuration. For these types of machines, this type of response will be considered on a case-by-case basis and is likely to be accepted provided:

- The control system does not introduce extended delays.
- The lagging current contribution is limited to within the equipment capability.

Fault Ride Through Testing

The manufacturer may demonstrate fault ride through using tests appropriate to the facilities available. However, a sufficiently large selection of results for balanced and unbalanced faults of varying duration must be provided to replicate the Mode A and B requirements.

ESO expects the tests to replicate each fault type (3-phase, phase-phase, two-phase to earth and single-phase to earth) with varying magnitudes. The tests should illustrate any changes in characteristics or internal operating modes that depend upon fault severity. For example DFIG wind turbines that utilise crowbar or similar devices should implement tests that illustrate the crowbar inception operating level and any consequential Power Park Unit characteristics, such as active and reactive power fault contribution and power recovery characteristic.

Tests should be repeated at a number of operating points. For example:

- Rated MW
- 70% MEL when MEL is greater than or equal to Rated MW
- SEL when SEL is no greater than DMOL.

Fault Ride Through testing involves applying simulated fault conditions, by applying short circuits, into known impedances to real systems. Compliance with fault ride through may be demonstrated by test conditions which are different to those specified in this sub section and different to the requirements specified in the grid code, provided:

- The test conditions are more severe.
- They encompass all of the various fault scenarios covered by the grid code.
- They can be used in conjunction with the studies to demonstrate compliance.

The set of tests shown in the table below is recommended.

% Retained Supergrid Voltage	3 phase	Phase to phase	2 phase to Earth	1 phase to Earth	Grid Code Ref
0	0.14s	0.14s	0.14s	0.14s	ECC.6.3.15.1/ECP.A.3.5.1
30	0.384				ECC.6.3.15.9 Including Figure ECC.6.3.15.9(b)/ ECP.A.3.5.1
50*	0.71s				
80	2.5s				
85	180s				

Figure D5 – Fault Ride Through – Type Tests

The purpose of the tests is to characterise the Power Park Unit such that its limit of operation for retained voltage (at the terminals of the Power Park Unit) is known. At the end of the test the results should indicate the level of voltage depression the unit can with stand for the times specified. Whilst the volts are depressed the Power Park Unit should deliver power in the same proportion as the volts and then recover once volts are restored.

Ideally Power Park Units will achieve the voltage levels and durations listed in the table above as this would indicate that the unit is fully compliant without the need for the study evidence. However these levels are unlikely to occur at the Power Park Unit terminals in practice because of the impedance between the fault location and the Power Park Unit. Consequently, increased test voltage levels above those specified are typically acceptable for most circumstances but require further study evidence (on a case by case basis) to demonstrate that the levels which occur at the a particular Power Park are greater than those which the Power Park Units are capable of riding through.

The tests should be performed on a single Power Park Unit using the test circuit shown below.

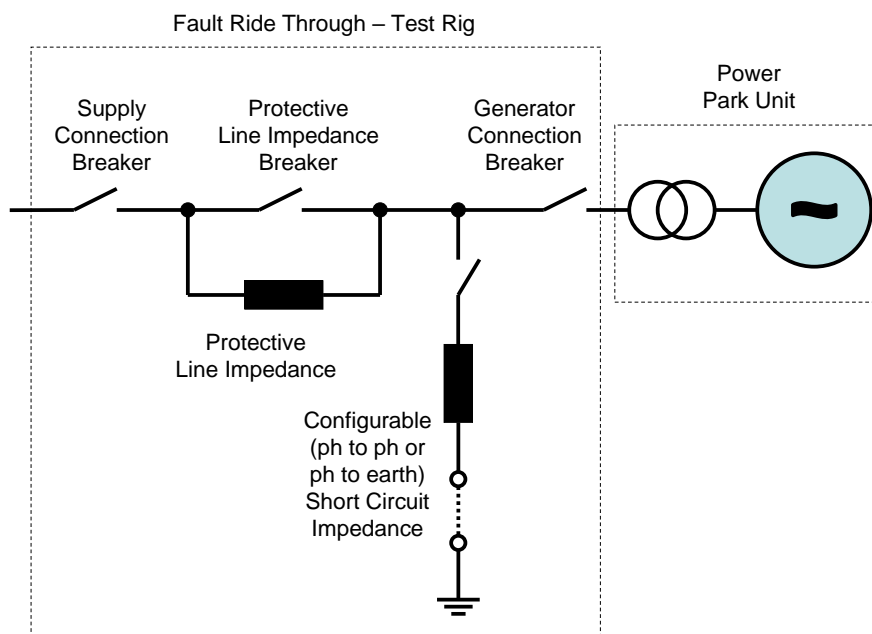

Figure D6

Test No	Description	Notes
1	<ul style="list-style-type: none"> • Operate the Power Park Unit (PPU) at nominal volts and appropriate output • Apply a 3ph short reducing the volts to 0% • Hold the voltage at 0% for 140ms • Allow the voltage to recover to nominal volts • Hold until conditions stabilise • If the unit passes this test proceed to test 3 otherwise proceed to test 2 	Mode A
2	<ul style="list-style-type: none"> • Repeat test 1 to determine the minimum retained volts until the unit can operate at for a period of 140ms 	Mode A

3	<ul style="list-style-type: none"> • Operate the Power Park Unit (PPU) at nominal volts and appropriate output. • Apply a 1ph to earth short circuit reducing the volts to 0% • Hold the voltage at 0% for 140ms • Allow the voltage to recover to nominal volts • Hold until conditions stabilise • If the unit passes this test proceed to test 5 otherwise proceed to test 4 	Mode A
4	<ul style="list-style-type: none"> • Repeat test 3 to determine the minimum retained volts the unit can operate at for a period of 140ms 	Mode A
5	<ul style="list-style-type: none"> • Operate the Power Park Unit (PPU) at nominal volts and appropriate output. • Apply a 2ph to earth short circuit reducing the volts to 0% • Hold the voltage at 0% for 140ms • Allow the voltage to recover to nominal volts • Hold until conditions stabilise • If the unit passes this test proceed to test 7 otherwise proceed to test 6 	Mode A
6	<ul style="list-style-type: none"> • Repeat test 5 to determine the minimum retained volts the unit can operate at for a period of 140ms 	Mode A
7	<ul style="list-style-type: none"> • Operate the Power Park Unit (PPU) at nominal volts and appropriate output. • Apply a phase to phase short circuit reducing the volts to 0% • Hold the voltage at 0% for 140ms • Allow the voltage to recover to nominal volts • Hold until conditions stabilise • If the unit passes this test proceed to test 9 otherwise proceed to test 8 	Mode A
8	<ul style="list-style-type: none"> • Repeat test 7 to determine the minimum retained volts the unit can operate at for a period of 140ms 	Mode A
11	<ul style="list-style-type: none"> • Operate the Power Park Unit (PPU) at nominal volts and appropriate output. • Apply a reduction in 3ph voltage to 30% • Hold the voltage at 30% for the corresponding time in Figure D5 • Increase the voltage to 90% • Hold until conditions stabilise or a minimum of 3 minutes 	Mode B

12	<ul style="list-style-type: none"> • Operate the Power Park Unit (PPU) at nominal volts and appropriate output. • Apply a reduction in 3ph voltage to 50% • Hold the voltage at 50% for the corresponding time in Figure D5 • Increase the voltage to 90% • Hold until conditions stabilise or a minimum of 3 minutes 	Mode B
13	<ul style="list-style-type: none"> • Operate the Power Park Unit (PPU) at nominal volts and appropriate output. • Apply a reduction in 3ph voltage to 80% • Hold the voltage at 80% for the corresponding time in Figure D5 • Increase the voltage to 90% • Hold until conditions stabilise or a minimum of 3 minutes 	Mode B
14	<ul style="list-style-type: none"> • Operate the Power Park Unit (PPU) at nominal volts and appropriate output. • Apply a reduction in 3ph voltage to 85% • Hold the voltage at 85% for the corresponding time in Figure D5 • Increase the voltage to 90% • Hold until conditions stabilise or a minimum of 3 minutes 	Mode B

Appendix E Response to Frequency Changes and Intermittent Power Source Variation

Scope

This Appendix is intended to provide guidance for manufacturers on the how control systems should react to changes in system frequency with fluctuations in the intermittent power source, with reference to [Power Park Module Signal Best Practice Guide](#) on the company website. This includes operation in both Frequency Sensitive and Limited Frequency Sensitive Modes.

Please note that this is just a guide and manufacturers are free to have their own designs and techniques to achieve the same effect on the system.

Several scenarios (high and low system frequency and various wind variations) are covered for each of four different operating points, to help explain how the response should be provided.

The four different operating points considered are

1. Frequency Sensitive Mode at full available MW / wind (high frequency response only)
2. Frequency Sensitive Mode at a de-load value below maximum available MW / wind
3. Limited Frequency Sensitive Mode at full available MW / wind
4. Limited Frequency Sensitive Mode at a de-load value below maximum available MW / wind

Frequency Sensitive Mode at Full Load

Scenario 1 – Start of a high frequency event followed by a drop in wind speed / available power.

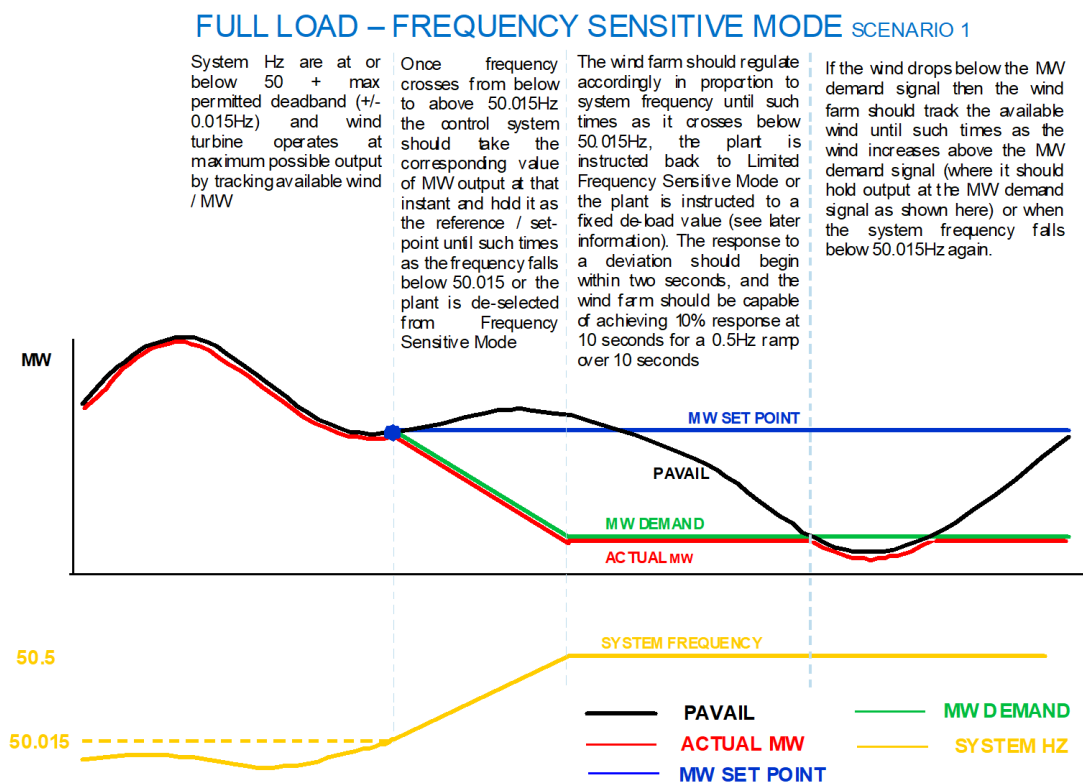

Scenario 2 – End of a high frequency event followed by another high frequency event.

FULL LOAD – FREQUENCY SENSITIVE MODE SCENARIO 2

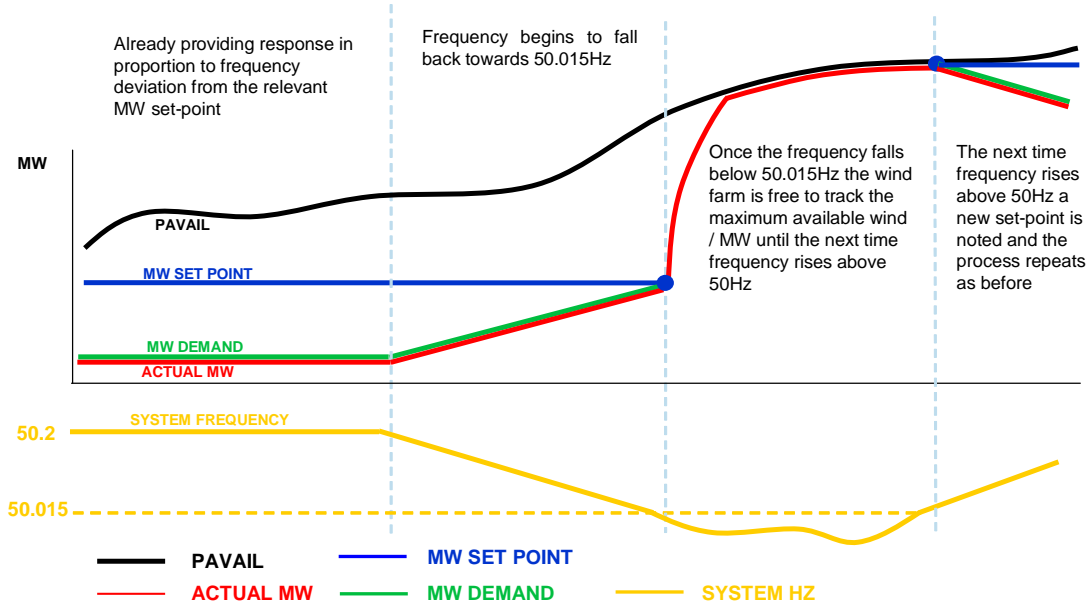

Scenario 3 – Instructed to Frequency Sensitive Mode (from Limited Frequency Sensitive Mode) while system frequency is already high.

FULL LOAD – FREQUENCY SENSITIVE MODE SCENARIO 3

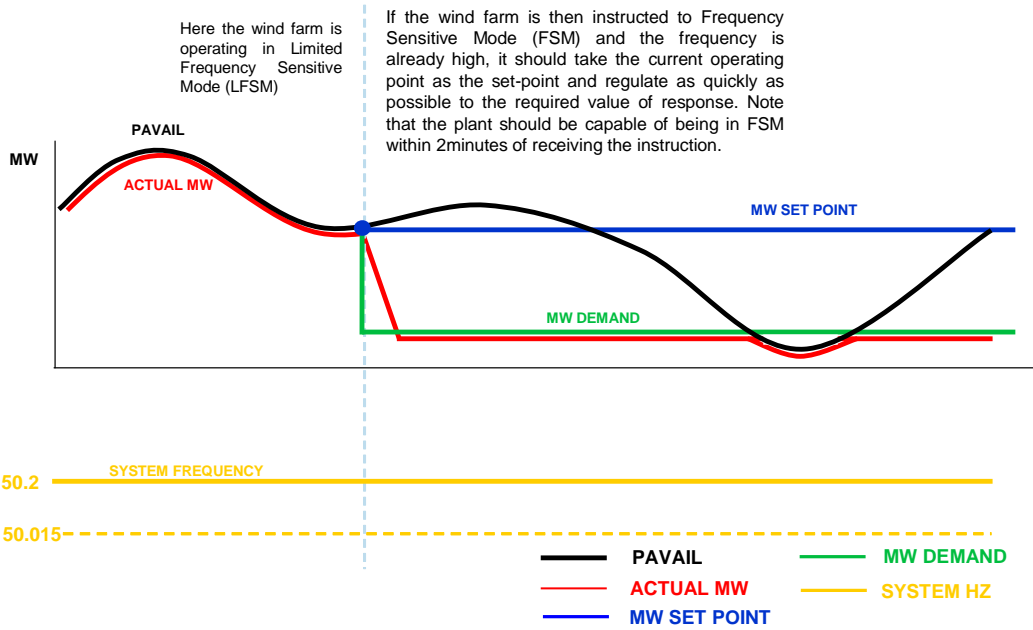

Scenario 4 – The case to avoid

FULL LOAD – FREQUENCY SENSITIVE MODE SCENARIO 4

THIS SHOULD BE AVOIDED

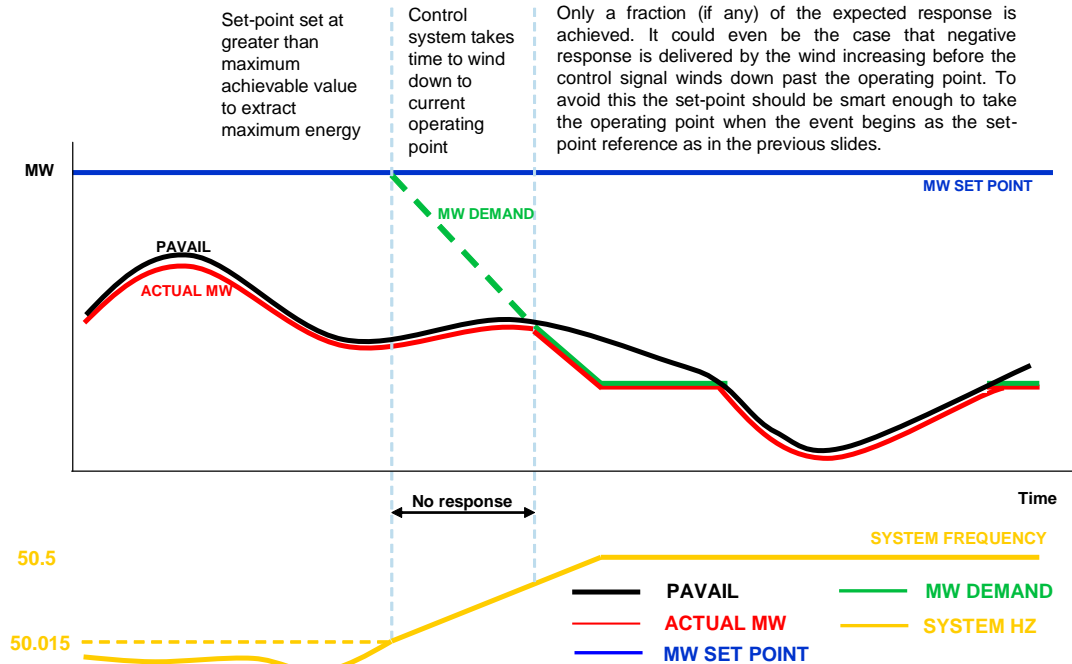

Set and Re-set Set-point

In order to provide consistent and sustainable response to high frequency the control system has to select the power park module output as a reference when the system frequency goes above 50Hz and release the reference when system frequency goes below 50Hz. The example below illustrates when to set and re-set the set-point using a real system frequency trace.

The green dots indicate where the system frequency passes from below 50Hz to above 50Hz. At this point the Power Park Modules control system should take and hold the corresponding MW output value at that instant as the Power Park Modules set-point. The Power Park Modules should then regulate in relation (wind conditions permitting) to that set-point until such times as the frequency falls below 50Hz (red dots), the unit is instructed back into Limited Frequency Sensitive Mode or the unit is instructed to a new de-loaded level

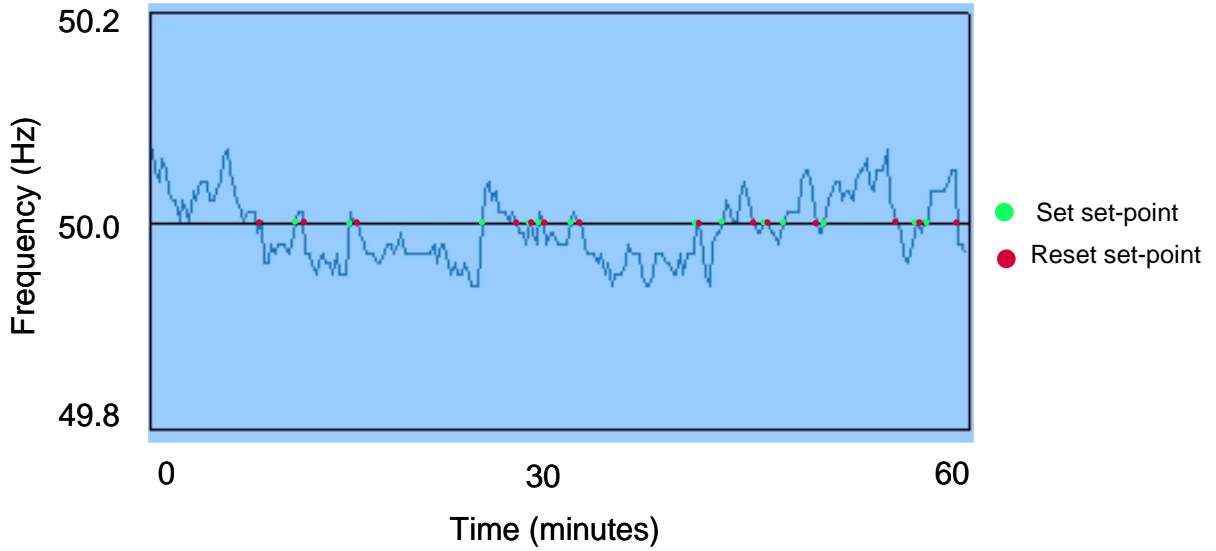

Frequency Sensitive Mode At De-Load

Scenario 1 – Increase in system frequency after instructed to de-load

DE-LOAD – FREQUENCY SENSITIVE MODE SCENARIO 1

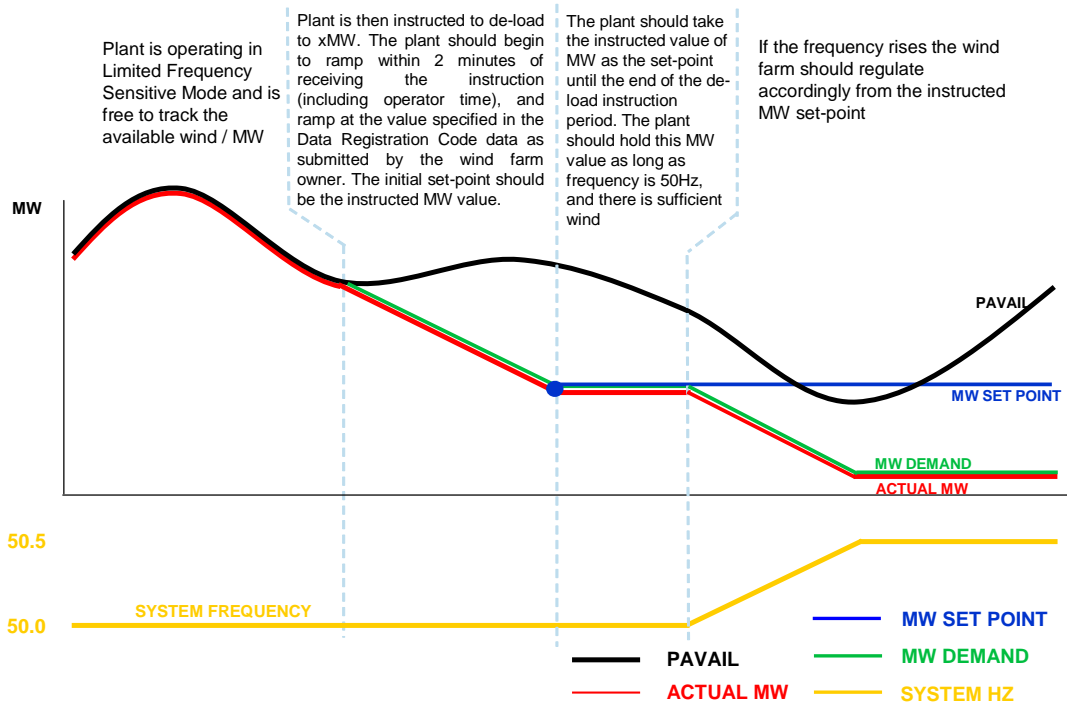

Scenario 2 – Decrease in system frequency after instructed to de-load

DE-LOAD – FREQUENCY SENSITIVE MODE SCENARIO 2

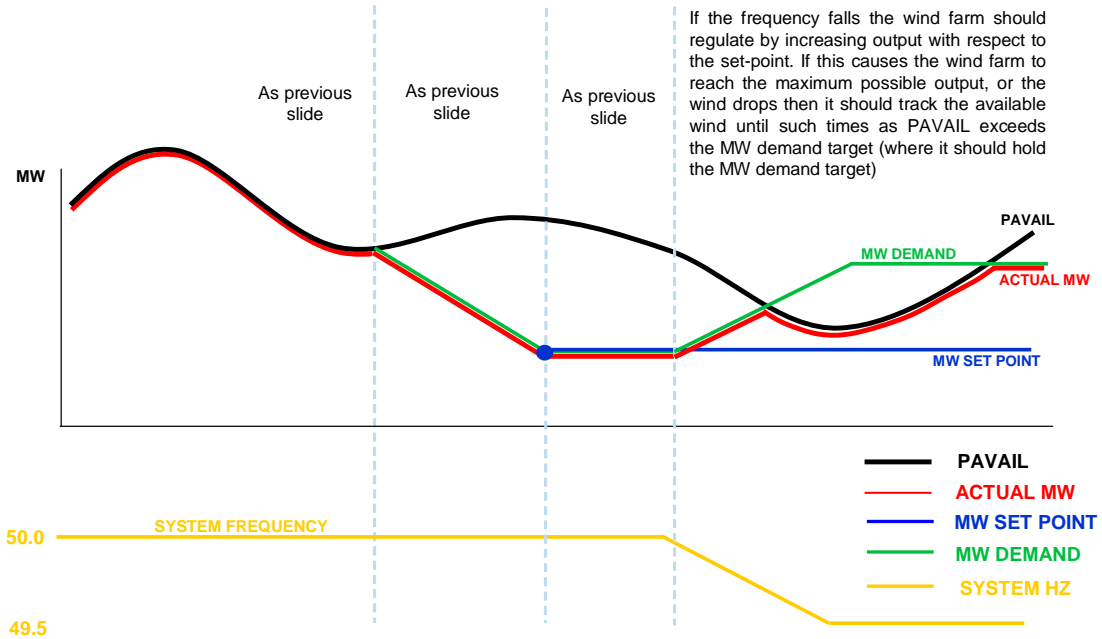

Limited Frequency Sensitive Mode

Scenario 1 – Limited Frequency Sensitive Mode from full load (frequency rising above 50.4Hz)

FULL LOAD – LIMITED FREQUENCY SENSITIVE MODE SCENARIO 1

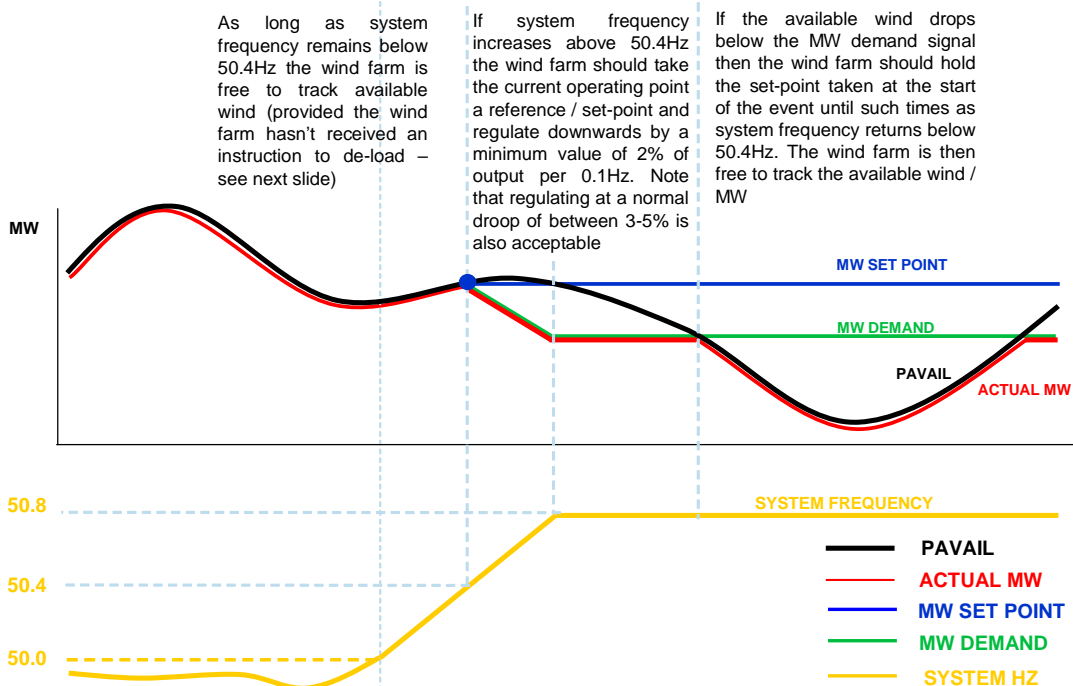

Scenario 2 – Limited Frequency Sensitive Mode from full load (frequency falling below 50.4Hz)

FULL LOAD – LIMITED FREQUENCY SENSITIVE MODE SCENARIO 2

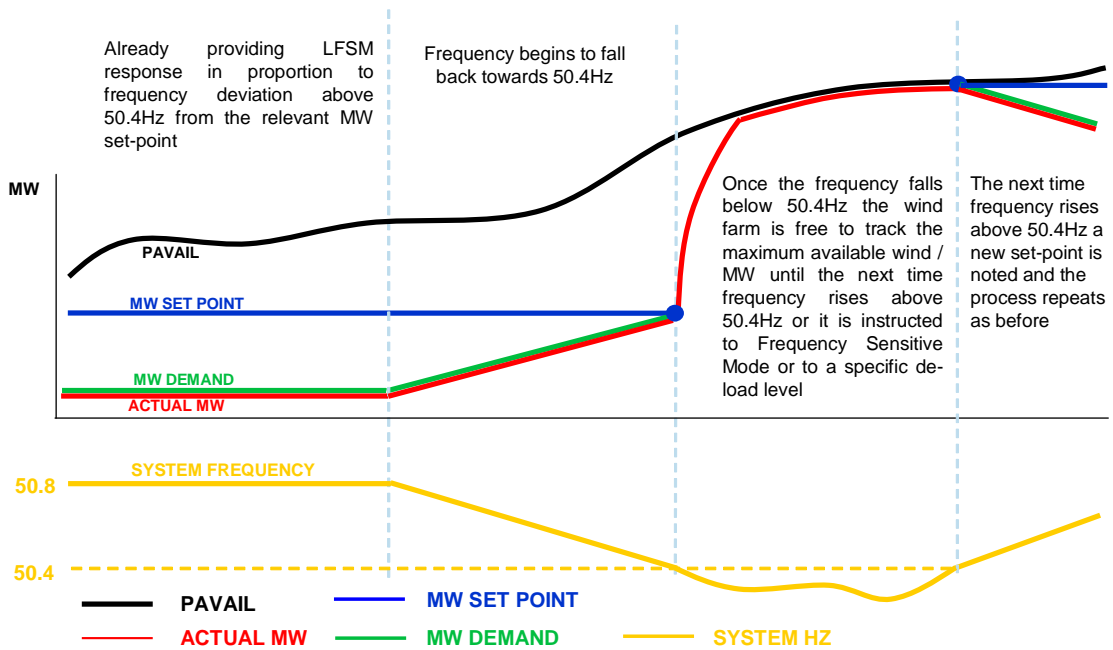

Scenario 3 – Limited Frequency Sensitive Mode from de-load position

DE-LOAD – LIMITED FREQUENCY SENSITIVE MODE SCENARIO 3

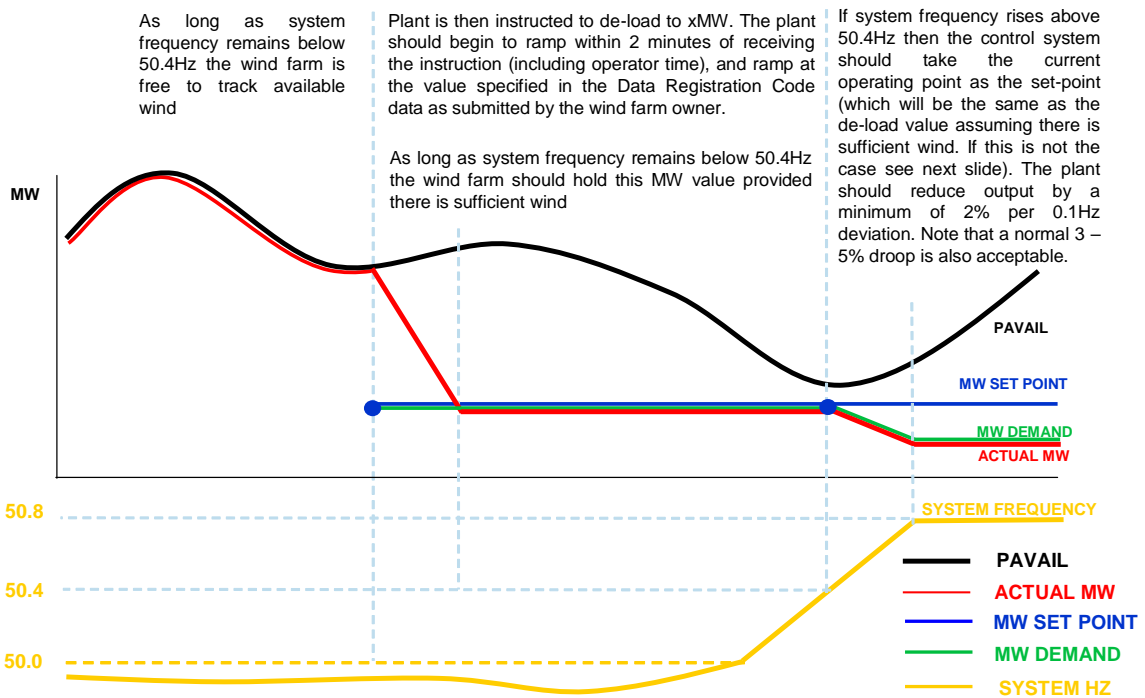

Scenario 4 – Limited Frequency Sensitive Mode from de-load position with a drop in available wind / MW

DE-LOAD – LIMITED FREQUENCY SENSITIVE MODE SCENARIO 4

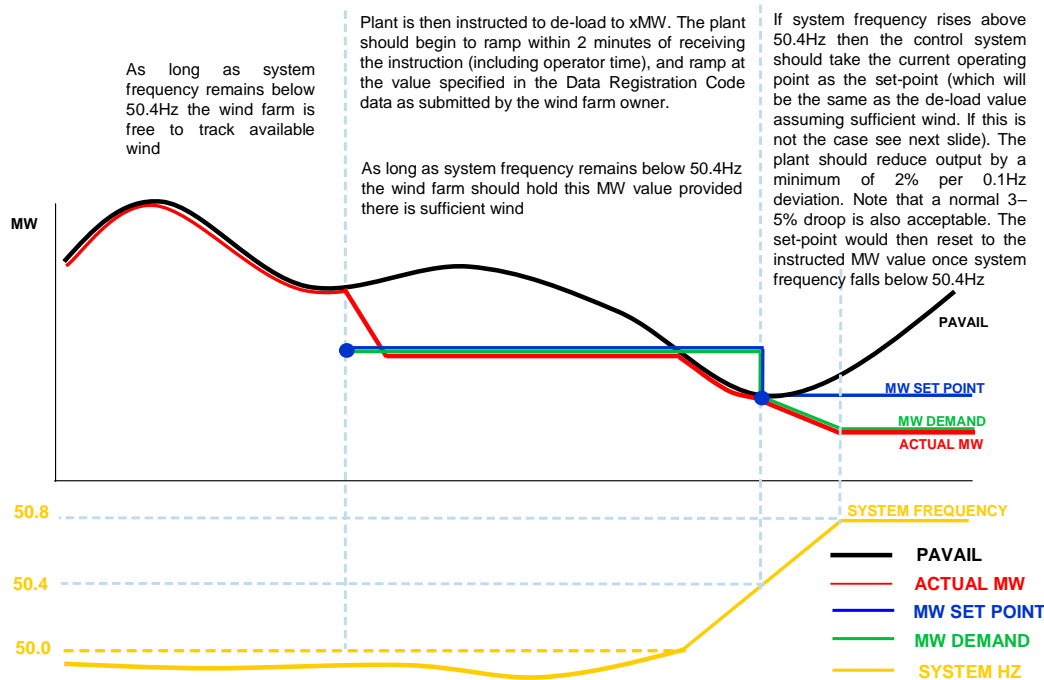

Summary

When de-loaded in GB the Power Park Module is instructed to a set MW value rather than a delta MW value from available MW (PAVAIL). While this may cause variability in the headroom for frequency response it allows the system to be balanced in an effective manner when large amounts of wind generation are connected (known as system balancing rather than frequency response).

For Frequency Sensitive Mode at full load the Power Park Modules should take and hold the operating point (MW value) at the instance the system frequency crosses from below 50.015 to above 50.015Hz as the set-point.

Limited Frequency Sensitive Mode at all times the Power Park Modules should take and hold the operating point (MW value) at the instance the system frequency crosses from below 50.4 to above 50.4Hz as the set-point.

For Frequency Sensitive Mode at a de-loaded value the Power Park Modules should take the instructed MW value as the set-point.

The guidance here applies to the behaviour of the complete Power Park Modules. If frequency controllers are implemented on individual turbines then variations to the suggestions here may have to be made to achieve the desired aims at the point of connection.

The Power Park Modules operator is still required to submit Final Physical Notification (FPN) and Maximum Export Limit (MEL) data as normal. The MEL figure submitted to ESO should be updated each time it differs from the available power by the greater of 5MW or 5% to ensure that the volume of available response can be correctly calculated.

Not providing the expected response to a frequency deviation may cause premature limits on the amount of wind turbine plant that the system can cope with without detrimental effects on frequency stability. It is therefore essential that the response provided should be repeatable (wind conditions permitting).

Appendix F Other Technical Information

Calculating Equivalent Impedance for Fault Ride Through Studies

The next two subsections, describe a simplified method of determining the fault ride through capability where the Point of Connection is not the Supergrid. This method relies on substituting the network between the Supergrid and Point of Connection with an equivalent impedance. A reasonable value for the equivalent impedance needs to be determined. The worst case scenario will be the minimum impedance. This minimum impedance can be derived from the maximum fault level at the connection point.

In some cases however, the maximum fault level may include contributions from other generation embedded between the Point of Connection and the Supergrid. Consequently the apparent impedance derived by the maximum fault level may be lower than the actual impedance. This will provide a worst case scenario. The maximum fault level data at the point of connection is readily available and is therefore a reasonable place to start. If this conservative impedance estimate is too arduous more detailed work will be needed to obtain a better impedance estimate.

For Power Parks with a point of connection to the Supergrid, the technique described below is still appropriate however the equivalent impedance (described above) is removed.

Positive Sequence Studies

The simplified positive sequence network below will generally be accepted as satisfying the 'pps' aspect of studies in Grid Code ECP.A.3.5.

In this conservative and simplified case, the network beyond the point of connection is represented by, a controlled Thevenin source and equivalent impedance. The equivalent impedance is derived from the maximum fault level at the point of connection.

The type validation tests were based on benchmarking the Power Park Unit at a node selected by the manufacturer. The impedance between the point of connection and the 'type validation node' must reflect the equivalent aggregated impedance of the Power Park between the point of connection and the same node.

The remaining impedance is the impedance between the 'type validation node' and the point at which the model representation begins (model interface node). In some cases the type validation node and the model interface node will be the same point and this impedance will not be included.

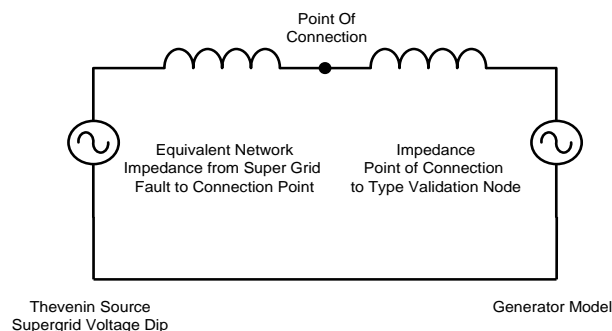

This simplified network can be implemented in a power system analysis package of the Developers choice using the voltage dips specified in Studies 3.1 & 3.2. The results at node 'A' are then compared to the type validation results to confirm ride through capability. The validity of the generator model's contribution to the retained voltage also needs to be confirmed by ensuring that the contribution at 'B' is comparable with the results obtained during the type validation tests for the equivalent profile at 'A'.

Negative Sequence Studies

Similarly the simplified negative sequence network below will generally be accepted as satisfying the 'nps' aspect of Grid Code ECP.A.3.5.

The negative sequence network is identical to the positive sequence network except that the generator model and the impedance between the 'type validation node' and the model interface node are replaced with an equivalent negative sequence estimate obtained during the type validation tests.

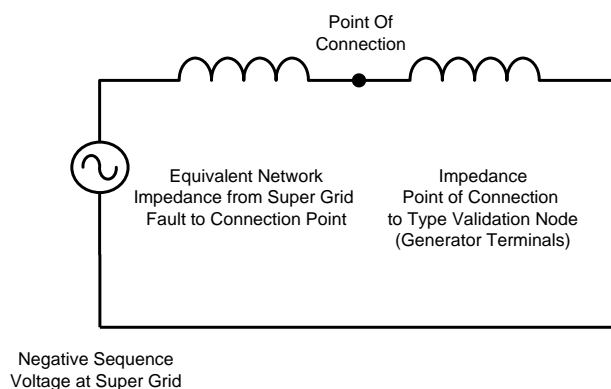

Solving the load flow for the above network using a voltage source corresponding to the negative sequence magnitude at the Supergrid results in a negative sequence voltage estimate at the type validation node ('A'). The results at node 'A' are then compared to the type validation results to confirm ride through capability.

In the event that the type validation tests show that there is no single equivalent negative sequence impedance then the type validation will record a family of impedances equating to retained negative sequence voltages at the type validation node. The negative sequence studies will then be run iteratively and the impedance value updated until reasonable convergence is obtained.

Technical Information on the Connection Bus Bar

This section illustrates the technical information relating to the connection bus bar that is provided by ESO or the host Transmission company.

Busbar on National Electricity Transmission System operating at Supergrid Voltage:

**Example 1
(Scottish Power Area 275 kV)**

275kV

Item	Max	Min	Unit
Symmetrical Three-phase short circuit level at instant of fault from GB Transmission System (based on transient impedance)	19000	1300	MVA
Equivalent system reactance between the Supergrid Busbar and Power Park Module Point of Connection.	3.9	3.6	% on 100 MVA
Total clearance time for fault on National Electricity Transmission System operating at Supergrid Voltage, cleared by System Back-up Protection (ECC.6.2.2.2.2)	800		msec

Equivalent Circuit between Supergrid Busbar and Power Park Module Point of Connection (showing transformer vector groups):



[Assume system 'nps' impedance pre-and post-fault such that ECC.6.1.6 limits met]

Equivalent Sequence Impedances for Calculating Unbalanced Short-Circuit Current Contribution

The generator is required to provide the fault infeed from the Power Park Module into the public transmission/distribution network. The data should be submitted in Grid Code DRC Schedule 14. The following transmission/distribution system equivalent sequence impedances may be used by the Generator in calculating unbalanced short-circuit current contribution from the Power Park Module at the entry point unless site specific values have been given. The Generator should confirm the system equivalent sequence impedances that have been used in the submission.

33kV: $Z1 = Z2 = 14.580 \angle 88.091^\circ$ % on a 100 MVA base
 $Z0 = 159.1 \angle 26.565^\circ$ % on a 100 MVA base

These impedances are based on the following assumptions:

- The PPS and NPS X/R ratio of the 33kV system is equal to 30
- The ZPS X/R ratio of the 33kV system is equal to 0.5
- The short-circuit current contribution from the 33kV distribution system for a 3-phase fault at the entry point is approximately 12kA
- The short-circuit current contribution from the 33kV distribution system for a 1-phase fault at the entry point is approximately 3kA

132kV: $Z1 = Z2 = 3.650 \angle 84.289^\circ$ % on a 100 MVA base
 $Z0 = 1.460 \angle 84.289^\circ$ % on a 100 MVA base

These impedances are based on the following assumptions:

- The PPS, NPS and ZPS X/R ratio of the transmission/distribution system is 10.
- The short-circuit current contribution from the transmission/distribution system for a 3-phase fault at the entry point is approximately 12kA
- The short-circuit current contribution from the transmission/distribution system for a 1-phase fault at the entry point is approximately 15kA

275kV: $Z1 = Z2 = 0.700 \angle 85.236^\circ$ % on a 100 MVA base
 $Z0 = 1.120 \angle 85.236^\circ$ % on a 100 MVA base

These impedances are based on the following assumptions:

- The PPS, NPS and ZPS X/R ratio of the 275kV system is equal to 12
- The short-circuit current contribution from the 275kV transmission system for a 3-phase fault at the entry point is approximately 30kA
- The short-circuit current contribution from the 275kV transmission system for a 1-phase fault at the entry point is approximately 25kA

400kV: $Z1 = Z2 = 0.361 \angle 85.914^\circ$ % on a 100 MVA base
 $Z0 = 0.516 \angle 85.914^\circ$ % on a 100 MVA base

These impedances are based on the following assumptions:

- The PPS, NPS and ZPS X/R ratio of the 400kV system is equal to 14
- The short-circuit current contribution from the 400kV transmission system for a 3-phase fault at the entry point is approximately 40kA
- The short-circuit current contribution from the 400kV transmission system for a 1-phase fault at the entry point is approximately 35kA

Appendix G Test Signal Schedule and Logsheet

Results to ESO should be submitted in spreadsheet format, with the signal data in columns arranged in the following tables. Signal data denoted by “#” is not essential, but if not provided, the column should remain in place but without values entered for it. If additional signals have been requested by ESO, they should be added to the right of the spreadsheet.

Compliance Test Signal Schedules

Table 1 – Onshore Power Park Modules Voltage Control & Reactive Capability								
	Col 1	Col 2	Col 3	Col 4	Col 5	Col 6	Col 7	Col 8
1	Time (10ms)	Active Power	Reactive Power	Connection Voltage	Speed /Frequency #	Freq Injection #	Logic / Test Start #	Statcom or Windfarm Reactive Power #
	Col 9	Col 10	Col 11	Col 12	Col 13	Col 14	Col 15	Col 16
1	Power Available	Wind Speed	Wind Direction	Voltage Setpoint				
2	State of Charge							
# Columns may be left blank but the column must still be included in the files								

Table 2 – Offshore Power Park Modules Voltage Control & Reactive Capability								
	Col 1	Col 2	Col 3	Col 4	Col 5	Col 6	Col 7	Col 8
1	Time (10ms)	Onshore Interface Point Active Power	Onshore Interface Point Reactive Power	Onshore Interface Point Voltage	Speed /Frequency #	Freq Injection #	Logic / Test Start #	Statcom or Windfarm Reactive Power #
	Col 9	Col 10	Col 11	Col 12	Col 13	Col 14	Col 15	Col 16
1	Power Available	Wind Speed	Wind Direction	Voltage Setpoint				
2	State of Charge							
# Columns may be left blank but the column must still be included in the files								

Table 3 - Power Park Modules Frequency Control								
	Col 1	Col 2	Col 3	Col 4	Col 5	Col 6	Col 7	Col 8
1	Time (100ms)	GEP Active Power	GEP Reactive Power #	GEP Connection Voltage #	Speed /Frequency	Freq Injection	Logic / Test Start	Statcom or Windfarm Reactive Power #
	Col 9	Col 10	Col 11	Col 12	Col 13	Col 14	Col 15	Col 16
1	Power Available	Wind Speed	Wind Direction					
2	State of Charge							
# Columns may be left blank but must still be included in the files								

Compliance Test Logsheet

Where test results are completed without any ESO presence but are relied upon as evidence of the compliance, they should be accompanied by a logsheet. This sheet should be legible, in English and detail the items set out below (ECP.A.4.3.8). Some of the items listed may not be relevant to all technology type addressed by guidance notes.

- Time and Date of test
- Name of Power Station and Power Generating Module if applicable.
- Name of Test engineer(s) and company name.
- Name of User(s) representative and company name.
- Type of testing being undertaken e.g., Voltage Control.
- Ambient Conditions e.g., temperature, pressure, wind speed, wind direction.
- Controller settings, e.g., voltage slope, frequency droop, voltage setpoint.

For each test the following items should be recorded as relevant to the type of test being undertaken. Where there is uncertainty on the information to be recorded this should be discussed with ESO in advance of the test.

Voltage Control Tests

- Start time of each test step.
- Active Power.
- Reactive Power.
- Connection Voltage.
- Voltage Control Setpoint, if applicable or changed.
- Voltage Control Slope, if applicable or changed.

- Terminal Voltage if applicable.
- Generator tap position or grid transformer tap position, as applicable.
- Number of Power Park Units in service in each Module, if applicable.

For Offshore Connections

- Offshore Grid Entry Point voltage.

Reactive Power Capability Tests

- Start time of test.
- Active Power.
- Reactive Power.
- Connection Voltage.
- Terminal Voltage if applicable.
- Generator Unit transformer tap position or grid transformer tap position as applicable.
- Number of Power Park Units in service in each Module, if applicable.

For Offshore Connections

- Offshore Grid Entry Point voltage.

Frequency Response Capability Tests

- Start time of test.
- Active Power.
- System Frequency.
- Droop setting of controller if applicable
- Number of Power Park Units in service in each Module, if applicable.

For Offshore Connections

- Offshore Grid Entry Point Active Power for each Power Park Module.

In addition to the above, any material change during the test, e.g., any Generating Units that trip/start, changes to tap positions, etc, should be recorded.

Appendix H Contacting National Grid

There are a number of different departments within National Grid that will be involved with this connection. The initial point of contact for National Grid will be your allocated Customer Connection Contract Manager for your Bilateral Agreement. If you are unsure of who your allocated Customer Connection Contract Manager is then the team can be contacted on box.ECC.Compliance@nationalgrideso.com.

For any correspondence relating to testing on the system following the Grid Code the IET process should be followed with notifications made to the '.Box.Tranreq' email address for England and Wales connections and '.Box.TR.Scotland' for all connections in Scotland.

Contact Address:

National Grid ESO, Faraday House, Warwick Technology Park, Gallows Hill, Warwick CV34 6DA

Faraday House, Warwick Technology Park,
Gallows Hill, Warwick, CV346DA

nationalgrideso.com

nationalgrid**ESO**