

Effectiveness factor assessment methodology

Mersey region reactive power service

14 October 2019



Effectiveness factor

To allow a fair comparison to be made for all potential options, effectiveness factors are used when the ESO assesses options. The effectiveness of an option is directly linked to its point of connection and determines the amount of reactive power required to meet the requirement. This will change the total volume expected to be invested or procured. For example, if a unit A was assessed to be 50% effective and unit B 100% effective, to resolve the same issue the system would need to use twice as much reactive power from unit A than B. Unit A would need to be significantly cheaper to have the same benefits.

Effectiveness changes in certain system conditions, for example with certain outages. The ESO calculates effectiveness factors for each point of connection against consistent (set of) background to ensure all providers are treated equally.

The below examples are all aimed to be illustrative, and provides approximations of potential differences in effectiveness. This will change when specific technical assessment for each region is completed. **Provider A in green, Provider B in red.**

Example 1

Provider A and B are connected at the same site. The site is run solid. The two different providers have different reactive ranges.

The providers would likely have the same effectiveness factor.

Note: If the site is run split, the providers would likely have different effectiveness factors.

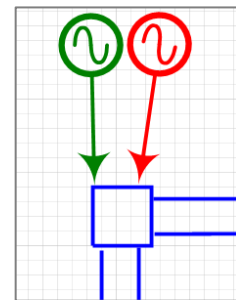

Example 2

Provider A and B are connected at different, adjacent, sites, which are geographically close together.

The providers would likely have similar effectiveness factors.

Note: Distance in the diagram is indicative only.

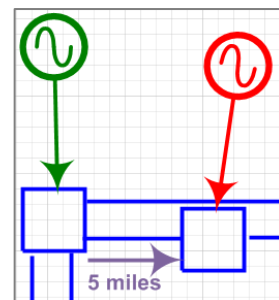

Example 3

Provider A and B are connected at different, adjacent, sites, which are geographically far apart.

The providers would likely have different effectiveness factors.

Note: Distance in the diagram is indicative only.

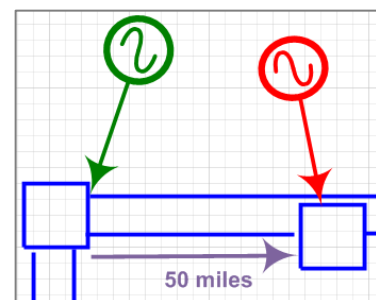

Example 4

Provider A and B are connected at different voltage levels. Provider B is connected at 132kV in the DNO network.

The ESO expects that options close to the source of the issue will have higher effectiveness factors.

If, for example, the source of the issue is at the transmission network, then Provider B that is connected at 132kV is likely to be less effective than Provider A. Providers connected at lower voltages than 132kV, in this example, would be expected to be even less effective.

Alternatively, if, for example, the source of the issue is at the distribution network¹, then Provider B is likely to be as effective (or more effective in some cases) than Provider A.

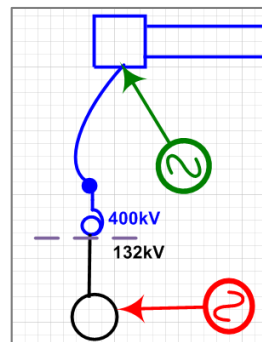

Example 5

The reactive power requirement is set specifically for a defined region. The region has been defined based on potential effectiveness.

Provider A is inside the defined region and Provider B is outside the defined region.

Providers outside the region are assessed as only being ineffective at resolving the issue.

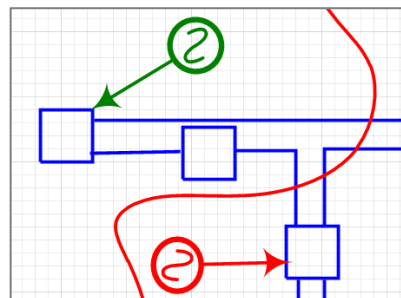

Calculation of effectiveness factors – an example

Many factors affect the effectiveness of an option, such as where and how it will connect to the network. Effectiveness factors are relative to a reference point on the network. The ESO chooses reference point(s) on the network based on where it is most effective to implement reactive power compensation to meet the requirement of the region of interest. Through system analysis the ESO calculates the effectiveness factors of relevant connection points with respect to the reference point(s).

In the example below, system analysis suggests that it is most effective to implement reactive power compensation at substation Y and that 100MVar of reactive power absorption is required to meet the system requirement.

¹ The [Power Potential Project](#), which aims to create a new reactive power market for distributed energy resources (DERs), will provide further insights into effectiveness of options connected to the distribution network. The ESO will learn from the Project and continuously improve their understanding of effectiveness.

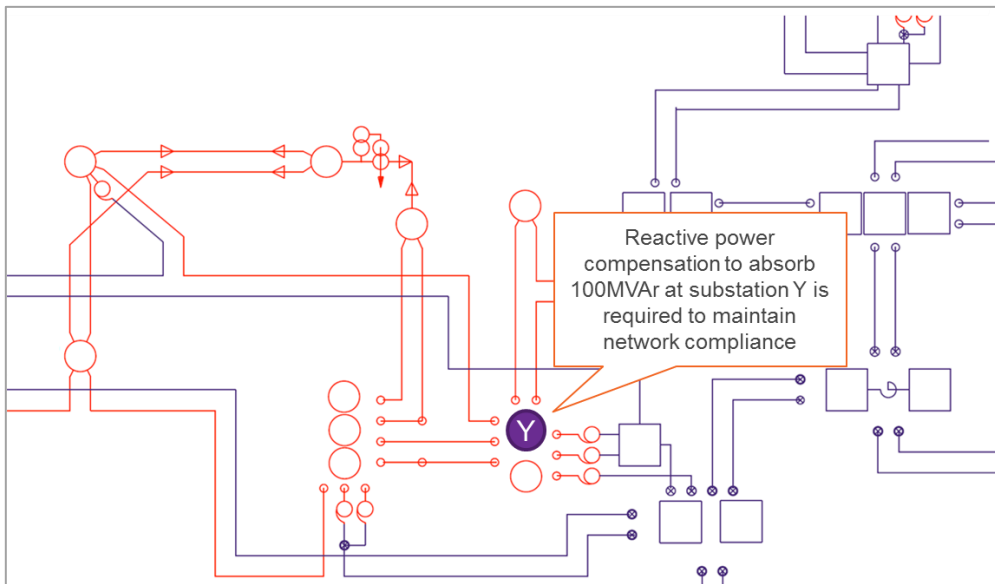

Next, the ESO calculates the effectiveness for options connecting at substation Z with substation Y as the reference point. The ESO models reactive power compensation to absorb 100MVar at substation Z and tests it under selected backgrounds and conditions. In this example, analysis results show that (on average) implementing reactive power compensation to absorb 100MVar at substation Z reduces the compensation required at substation Y from 100MVar to 25MVar.

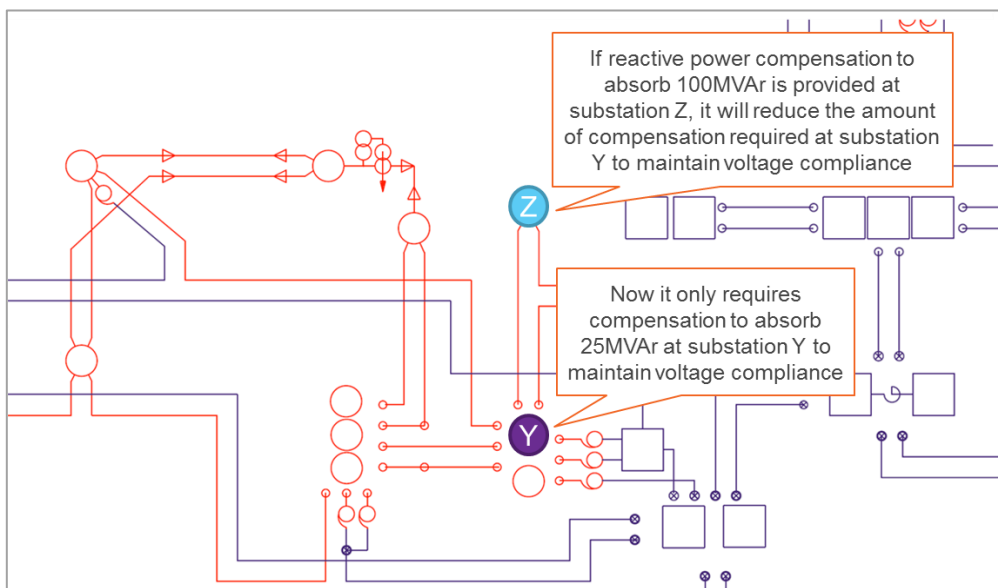

The ESO can then approximate the effectiveness for any options connecting at substation Z as $(100-25)/100 = 0.75$ with respect to the reference point.

$$\text{Effectiveness factor} = \frac{\text{original compensation at ref. point Y} - \text{resulting compensation at ref. point Y}}{\text{size of option at Z}}$$

For option which is connected to the distribution network, the ESO will work with the relevant DNO to calculate the effectiveness factor of an option. The DNO will calculate the impact of a distribution-connected option to the closest GSP(s). With this information, the ESO can then calculate the effectiveness factor of a distribution-connected option with respect to the reference point in the transmission network.