



## **CONSULTATION DOCUMENT VOLUME 2**

*(LEGAL TEXT AND WORKING GROUP CONSULTATION RESPONSES)*

### **CUSC Amendment Proposal CAP169**

#### **Provision of Reactive Power from Power Park Modules, Large Power Stations and Embedded Power Stations**

Amendment Ref	CAP169
Issue	V1.0
Date of Issue	15/09/09
Prepared by	NATIONAL GRID

I DOCUMENT CONTROL

a National Grid Document Control

Version	Date	Author	Change Reference
V1.0	15/09/09	CAP169 WG	Consultation for comment

b Distribution

Name	Organisation
The Gas and Electricity Markets Authority	Ofgem
CUSC Parties	Various
Panel Members	Various
National Grid Industry Information Website	

PART A LEGAL TEXT - ORIGINAL

PART B LEGAL TEXT - WGAA1

PART C LEGAL TEXT - WGAA2

PART D LEGAL TEXT - WGAA3

PART E CHANGES TO THE METHODOLOGY FOR THE AGGREGATION OF REACTIVE POWER METERING

PART F REPRESENTATIONS TO THE WORKING GROUP CONSULTATION

**PART A: LEGAL TEXT TO MODIFY THE CUSC – ORIGINAL**

The text required to give effect to each part of the proposals is:

- Part 1: Section 1, Section 4, Section 11, Schedule 2 and Schedule 3
- Part 2: Schedule 3 (2.8ii and Appendix 6, 1.2)
- Part 3: Section 11 (definitions for Network Operator, Reactive Despatch Network Restriction and Pre-Connection Reactive Despatch Network Restriction) and Schedule 3 (Appendix 1, 2e and Appendix 2, 2e)

**The following pages show the marked up changes for the following sections of the CUSC:**

- 1. Section 1**
- 2. Section 4**
- 3. Section 11**
- 4. Schedule 2**
- 5. Schedule 3**

Please note, only the specific clauses requiring amendment have been included.

Changes are marked as outlined in the table below:

<b>Legend:</b>
<u>Insertion</u>
<del>Deletion</del>

## **CUSC Section 1**

### 1.3.3 Mandatory Services Agreements

- (a) **The Company** and each **User** if a **Generator** shall, as between **The Company** and that **User**, in respect of the **Generating Units, DC Converters and Power Park Modules** from which that **User** is required to provide the **Mandatory Ancillary Services** in accordance with the **Grid Code**, enter into and comply with a **Mandatory Services Agreement** where applicable in accordance with Paragraph 1.3.3(b) in a form to be agreed between **The Company** and that **User** but based substantially on the form set out in Exhibit 4 in Schedule 2 (with necessary changes to enable the operation of those provisions, and those in Section 4 and Schedule 3 where the **Generating Units, DC Converters or Power Park Modules (as the case may be)** are not registered as **BM Unit(s)**).

## **CUSC Section 4**

4.1.1.1 The provisions of this Paragraph 4.1 shall apply to **Users** which are **Generators** in respect of **Generating Units, DC Converters and Power Park Modules** from which they are required to provide the **Mandatory Ancillary Services** to **The Company** in accordance with the **Grid Code** (for the avoidance of doubt, as determined by any direction in force from time to time and issued by the **Authority** relieving any such **User** from the obligation under its **Licence** to comply with such part or parts of the **Grid Code** or any **Distribution Code** or, in the case of **The Company**, the **Transmission Licence**, as may be specified in such direction).

4.1.1.2 In respect of **Generating Unit(s), DC Converter(s) and Power Park Module(s)** which are required to provide **Mandatory Ancillary Services** to **The Company** in accordance with the **Grid Code** and which are not registered as **BM Unit(s)**, the **Mandatory Service Agreement** shall detail how the provisions of Section 4 and Schedule 3 of the **CUSC** which refer to **BM Unit(s)** shall (notwithstanding such **Generating Unit(s), DC Converter(s) and Power Park Module(s)** are not registered as **BM Unit(s)**) apply.

---

4.1.2.4 (a) For the avoidance of doubt, nothing in this Paragraph 4.1.2.4 or any **Mandatory Services Agreement** shall affect the provisions of **Grid Code OC 2** and/or **BC 1** concerning the redeclaration in relation to any **BM Unit** (or where applicable, any **CCGT Unit or Power Park Unit**) of a revised capability to provide **Leading** and/or **Lagging** Mvar, where applicable at the generator stator terminals.

(b) All such redeclarations at the generator stator terminals submitted pursuant ~~thereto~~ Grid Code OC 2 and/or BC 1 may include the revised capability (in the case of **CCGT Units and Power Park Units**, of the relevant **BM Unit**) at **Rated MW** at the **Commercial Boundary**. Such capability shall be derived from the capability at the generator stator terminals by application of the ~~formula~~ applicable formulae set out in ~~Part 4~~ Parts 1, 2 or 3 of Appendix 8 to Schedule 3, Part I ~~or, in the case of a CCGT Module, derived by the summation of the revised capability of each relevant CCGT Unit at the high voltage side of the CCGT Unit step-up transformer (after application of the formula set out in Section 1 of Part 2 of Appendix 8 to Schedule 3, Part I to the capability of each relevant CCGT Unit at the generator stator terminals and by application of the formula set out in Section 2 of Part 2 of Appendix 8 to Schedule 3, Part I).~~

(bc) Where a redeclaration of capability to provide **Leading** and/or **Lagging** Mvars at **Rated MW** does not specify such revised capability at the **Commercial Boundary**, then **The Company** shall calculate the revised capability at **Rated MW** at the **Commercial Boundary** by application of the ~~relevant formula~~ applicable formulae set out in ~~Part 4~~ Parts 1, 2 or 2 (as the case may be) 3 of Appendix 8 ~~of~~ to Schedule 3, Part I.

(ed) Any revised capability of a **BM Unit** at **Rated MW** at the **Commercial Boundary** shall constitute the respective values of  $QR_{lead}$  and  $QR_{lag}$  as referred to in Section 2 of Appendix 3 of Schedule 3, Part I.

(de) In order to calculate any payments which fall due in accordance with this Paragraph 4.1.2 and a **Mandatory Services Agreement**, following commencement of the relevant clause of the **Mandatory Services Agreement**, **The Company** shall calculate the values of  $QR_{lead}$  and  $QR_{lag}$  in accordance with the applicable formulae contained in Parts 1, 2 or 3 of Appendix 8 ~~of~~ to Schedule 3, Part I.

---

*Section 4 - CAP169 original*

- 4.1.2.9 It is acknowledged by **The Company** and each **User** that the provision by that **User** of the **Obligatory Reactive Power Service** in accordance with the terms of the **CUSC** and the **Mandatory Services Agreement** shall not relieve it of any of its obligations set out in the **Grid Code** including without limitation its obligation set out in **Grid Code CC 8.1** to provide **Reactive Power** (supplied otherwise than by means of synchronous or static compensators except in the case of a **Power Park Module** where synchronous or static compensation within the **Power Park Module** may be used to provide **Reactive Power**) in accordance with **Grid Code CC 6.3.2**.

## **CUSC - SECTION 11 - INTERPRETATION AND DEFINITIONS**

“DC Converter”

as defined in the Grid Code;

“Network Operator”

as defined in the Grid Code;

“Power Park Unit”

as defined in the Grid Code;

**“Power Station”**

as defined in the Grid Code; ~~an installation comprising one or more **Generating Units** (even where sited separately) owned and/or controlled by the same **Generator**, which may reasonably be considered as being managed as one **Power Station**;~~

“Pre-Connection Reactive  
Despatch Network Restriction”

with respect to any **Embedded Generating Unit, Embedded Power Park Module or DC Converter** at an **Embedded DC Converter Station**, a **Reactive Despatch Network Restriction** notified to **The Company** pursuant to the **Grid Code** prior to the **Commissioning Programme Commencement Date** for such **Generating Unit, Power Park Module or DC Converter** which results in the **Generating Unit, Power Park Module or DC Converter** being unable to comply with a **Reactive Despatch Instruction** from **The Company** to provide 0 Mvar at the **Commercial Boundary**;

“Reactive Despatch Network  
Restriction”

as defined in the Grid Code;

## **CUSC Schedule 2, Exhibit 4**

### **3.2 Term and Suspension**

[3.2.1 The provisions of this Clause 3 shall be deemed to have applied in relation to each **BM Unit** with effect from 00.00 hours on the [date hereof] [**Commencement Date**] and, subject always to Sub-Clause 3.2.2, shall continue thereafter unless and until the earlier of termination of the **CUSC Schedule** and termination of this **Mandatory Services Agreement**. For the avoidance of doubt, in the event this **Mandatory Services Agreement** is terminated in relation to any individual **BM Unit**, the provisions of this Clause 3 shall terminate in relation to that **BM Unit** only.] *OR*

[3.2.1 The provisions of Sub-Clauses 3.3 to 3.6 inclusive shall apply with effect from 00.00 hours on the date on which it is demonstrated (having regard to industry practice) to the reasonable satisfaction of **The Company** that each of the [CCGT] [BM] [\[Non-Synchronous Generating\] Units](#) complies with the provisions of **Grid Code CC** 6.3.2 and 6.3.4 [as applicable](#) (or the coming into force of a direction issued by the **Authority** relieving the **User** of the obligation under its **Licence** to comply therewith) or (where **The Company** in its sole discretion requires **Reactive Power** from the **BM Units** before then for the purposes of security of the **National Electricity Transmission System**) such earlier date as **The Company** may agree with the **User** and, subject always to Sub-Clause 3.2.3, shall continue thereafter unless and until the earlier of termination of the **CUSC Schedule** and termination of this **Mandatory Services Agreement**. For the avoidance of doubt, the issue by **The Company** in relation to the **BM Unit** of a **Reactive Despatch Instruction** to unity power factor or zero Mvar shall not imply demonstration to **The Company's** reasonable satisfaction of compliance as referred to above nor imply in relation to the **BM Unit** agreement by **The Company** of an earlier date as referred to herein.

3.2.2 No demonstration referred to in Sub-Clause 3.2.1 shall take place until the **User** shall have demonstrated to **The Company's** reasonable satisfaction (having regard to industry practice) that [each [CCGT] [BM] **Unit's Excitation System**, and in particular [\(where applicable\) the Under-excitation Limiter](#), [\[the continuously-acting automatic control system required to provide control of the voltage or zero transfer of Reactive Power with respect to each \[Power Park Module\]\[DC Converter\]](#)] has been successfully commissioned and complies with the provisions of **Grid Code CC** 6.3.8.]

3.2.2/3 In relation to any **BM Unit**, the provisions of this Clause 3 (except this Sub-Clause 3.2) shall be suspended and have no force and effect upon the coming into effect, and for the duration of, any agreement (referred to in the **CUSC Schedule** as a "**Market Agreement**" and being either a new **Ancillary Services Agreement** or an agreement incorporating provisions into this **Mandatory Services Agreement**) which may be entered into between the Parties pursuant to Paragraph 3 of the **CUSC Schedule** for the provision by the **User** in relation to that **BM Unit** of:-

- (a) the **Obligatory Reactive Power Service** but with alternative payment arrangements to those provided in this Clause 3; or
- (b) an **Enhanced Reactive Power Service**.

For the avoidance of doubt, with effect from the expiry or termination of any **Market Agreement** such provisions shall in relation to that **BM Unit** cease to be suspended and shall resume full force and effect.

3.2.3/4 Termination or suspension of this Clause 3 shall not affect the rights and obligations of the **Parties** accrued as at the date of termination or suspension.

### **3.3 Capability Data**

3.3.1 The **Parties** agree that, for the purposes of the Appendices to the **CUSC Schedule**:-



SCHEDULE 2, EXHIBIT 4 CAP169 original

- (a) the figures set out in Table B of Appendix 1, Section A, Part I represent for each **BM Unit** the **Reactive Power** capability at **Rated MW** which the **User** is obliged to provide under and in accordance with ~~the Connection Conditions of the Grid Code CC 6.3.2(a)~~, together with **Reactive Power** capability at other levels of **MW Output** as specified therein by reference to the **Generator Performance Chart** submitted in accordance with **Grid Code OC 2.4.2** and measured at the generator stator terminals; and
- (b) the figures set out in Table A of Appendix 1, Section A, Part I shall constitute for each of the **BM Units** the value of  $QC_{lead}$  and  $QC_{lag}$  referred to in Section 2 of Appendix 3 to the **CUSC Schedule** representing the **Reactive Power** capability at **Rated MW** shown at the **Commercial Boundary** (by application of the formulae set out in Appendix ~~88, Part 1~~ to the **CUSC Schedule**).] *OR*
- (a) the figures set out in Table B of Appendix 1, Section A, Part I represent for each relevant **CCGT Unit** the **Reactive Power** capability at **Rated MW** which the **User** is obliged to provide under and in accordance with ~~the Connection Conditions of the Grid Code CC 6.3.2(a)~~, together with **Reactive Power** capability at other levels of **MW Output** as specified therein by reference to the **Generator Performance Chart** submitted in accordance with **Grid Code OC 2.4.2** and measured at the generator stator terminals; and
- (b) the figures set out in summary Table C of Appendix 1, Section A, Part I represent for the **BM Unit** the **Reactive Power** capability of each relevant **CCGT Unit** at **Rated MW** (derived from Table B) but shown at the high voltage side of the **Generating Unit** step-up transformer by application of the ~~formula~~ formulae set out in Appendix 8, Part 2 to the **CUSC Schedule**; and
- (c) the figures set out in Table A of Appendix 1, Section A, Part I shall constitute for the **BM Unit** the value of  $QC_{lead}$  and  $QC_{lag}$  referred to in Section 2 of Appendix 3 to the **CUSC Schedule** representing the **Reactive Power** capability of the **BM Unit** at **Rated MW** shown at the **Commercial Boundary** (derived by the summation of the **Reactive Power** capability of each relevant **CCGT Unit** at **Rated MW** extracted from summary Table C and by application of the formulae set out in Appendix 8, Part 2 to the **CUSC Schedule**.)
- (a) the figures set out in Table B of Appendix 1, Section A, Part I represent for the **BM Unit** the **Reactive Power** capability at **Rated MW** and at various other **Active Power** output levels which the **User** is obliged to provide under and in accordance **Grid Code CC 6.3.2(c)** or **6.3.2(d)(i)** (as the case may be) by reference to the **Generator Performance Chart** submitted in accordance with **Grid Code OC 2.4.2** and measured at either the **Grid Entry Point** in England and Wales or at the HV side of the 33/132 kV or 33/275 kV or 33/400 kV transformer for **Users** connected to the **National Electricity Transmission System** in Scotland or the **User System Entry Point** if **Embedded**; and
- (b) the figures set out in Table A of Appendix 1, Section A, Part I shall constitute for the **BM Unit** the value of  $QC_{lead}$  and  $QC_{lag}$  referred to in Section 2 of Appendix 3 to the **CUSC Schedule** representing the **Reactive Power** capability at **Rated MW** shown at the **Commercial Boundary**.
- (a) the figures set out in Table B of Appendix 1, Section A, Part I represent for each relevant **Non-Synchronous Generating Unit** the **Reactive Power** capability at **Rated MW** which the **User** is obliged to provide under and in accordance with **Grid Code CC 6.3.2(d)(ii)**, together with **Reactive Power** capability at other levels of **MW Output** as specified therein by reference to the **Generator Performance Chart** submitted in accordance with **Grid Code OC 2.4.2** and measured at the generator stator terminals; and

SCHEDULE 2, EXHIBIT 4 CAP169 original

- (b) where applicable, the figures set out in summary Table C of Appendix 1, Section A, Part I represent for a **Power Park Module** the **Reactive Power** capability of each relevant **Power Park Unit** at **Rated MW** (derived from Table B) but shown at the high voltage side of the **Generating Unit** step-up transformer by application of the formulae set out in Appendix 8, Part 3 to the **CUSC Schedule**; and
- (c) the figures set out in Table A of Appendix 1, Section A, Part I shall constitute for the **BM Unit** the value of  $QC_{lead}$  and  $QC_{lag}$  referred to in Section 2 of Appendix 3 to the **CUSC Schedule** representing the **Reactive Power** capability of the **BM Unit** at **Rated MW** shown at the **Commercial Boundary** (where applicable, derived by the summation of the **Reactive Power** capability of each relevant **Power Park Unit** at **Rated MW** extracted from summary Table C and by application either of the formulae set out in Appendix 8, Part 3 to the **CUSC Schedule** or such other methodology as **The Company** and the **User** may agree in writing.]
-

**APPENDIX 1 – DATA**  
**SECTION A (REACTIVE POWER)**

**Part I**

**Capability Tables (Relevant Zone [ ])**

[TABLES BELOW FOR USE WHERE GRID CODE CC6.3.2(a) APPLICABLE (EXCEPT FOR CCGT MODULES)]

BM Unit No.

**REACTIVE POWER CAPABILITY AT COMMERCIAL BOUNDARY** (at rated stator terminal and nominal system voltage)

TABLE A	LEAD (Mvar)	LAG (Mvar)
AT RATED MW		

**REACTIVE POWER CAPABILITY AT GENERATOR STATOR TERMINAL** (at rated terminal voltage)

TABLE B	MW	LEAD (Mvar)	LAG (Mvar)
AT RATED MW			
AT FULL OUTPUT (MW)			
AT MINIMUM OUTPUT (MW)			

BM Unit No.

**REACTIVE POWER CAPABILITY AT COMMERCIAL BOUNDARY** (at rated stator terminal and nominal system voltage)

TABLE A	LEAD (Mvar)	LAG (Mvar)
AT RATED MW		

SCHEDULE 2, EXHIBIT 4 CAP169 original

**REACTIVE POWER CAPABILITY AT GENERATOR STATOR TERMINAL** (at rated terminal voltage)

<b>TABLE B</b>	<b>MW</b>	<b>LEAD (Mvar)</b>	<b>LAG (Mvar)</b>
<b>AT RATED MW</b>			
<b>AT FULL OUTPUT (MW)</b>			
<b>AT MINIMUM OUTPUT (MW)</b>			

BM Unit No.

**REACTIVE POWER CAPABILITY AT COMMERCIAL BOUNDARY** (at rated stator terminal and nominal system voltage)

<b>TABLE A</b>	<b>LEAD (Mvar)</b>	<b>LAG (Mvar)</b>
<b>AT RATED MW</b>		

**REACTIVE POWER CAPABILITY AT GENERATOR STATOR TERMINAL** (at rated terminal voltage)

<b>TABLE B</b>	<b>MW</b>	<b>LEAD (Mvar)</b>	<b>LAG (Mvar)</b>
<b>AT RATED MW</b>			
<b>AT FULL OUTPUT (MW)</b>			
<b>AT MINIMUM OUTPUT (MW)</b>			

BM Unit No.

**REACTIVE POWER CAPABILITY AT COMMERCIAL BOUNDARY** (at rated stator terminal and nominal system voltage)

<b>TABLE A</b>	<b>LEAD (Mvar)</b>	<b>LAG (Mvar)</b>
<b>AT RATED MW</b>		

SCHEDULE 2, EXHIBIT 4 CAP169 original

**REACTIVE POWER CAPABILITY AT GENERATOR STATOR TERMINAL** (at rated terminal voltage)

<b>TABLE B</b>	<b>MW</b>	<b>LEAD (Mvar)</b>	<b>LAG (Mvar)</b>
<b>AT RATED MW</b>			
<b>AT FULL OUTPUT (MW)</b>			
<b>AT MINIMUM OUTPUT (MW)</b>			

OR

[TABLES BELOW FOR USE WHERE GRID CODE CC6.3.2(a) APPLICABLE - CCGT MODULES ONLY]

**REACTIVE POWER CAPABILITY AT COMMERCIAL BOUNDARY** (at rated stator terminal and nominal system voltage)

<b>TABLE A</b>	<b>MW</b>	<b>LEAD (Mvar)</b>	<b>LAG (Mvar)</b>
<b>AT RATED MW</b>			

**REACTIVE POWER CAPABILITY AT GENERATOR STATOR TERMINAL** (at rated terminal voltage)

CCGT Unit No. [            ]

<b>TABLE B</b>	<b>MW</b>	<b>LEAD (Mvar)</b>	<b>LAG (Mvar)</b>
<b>AT RATED MW</b>			
<b>AT FULL OUTPUT (MW)</b>			
<b>AT MINIMUM OUTPUT (MW)</b>			

*SCHEDULE 2, EXHIBIT 4 CAP169 original*

CCGT Unit No. [            ]

<b>TABLE B</b>	<b>MW</b>	<b>LEAD (Mvar)</b>	<b>LAG (Mvar)</b>
<b>AT RATED MW</b>			
<b>AT FULL OUTPUT (MW)</b>			
<b>AT MINIMUM OUTPUT (MW)</b>			

CCGT Unit No. [            ]

<b>TABLE B</b>	<b>MW</b>	<b>LEAD (Mvar)</b>	<b>LAG (Mvar)</b>
<b>AT RATED MW</b>			
<b>AT FULL OUTPUT (MW)</b>			
<b>AT MINIMUM OUTPUT (MW)</b>			

**REACTIVE POWER CAPABILITY AT HV SIDE OF STEP-UP TRANSFORMER** (at rated terminal and nominal system voltage)

<b>SUMMARY TABLE C</b>	<b>RATED MW</b>	<b>LEAD (Mvar)</b>	<b>LAG (Mvar)</b>
<b>CCGT UNIT</b>			

OR

[TABLES BELOW FOR USE WHERE GRID CODE CC6.3.2(c) or (d)(i) APPLICABLE]

}

**REACTIVE POWER CAPABILITY AT COMMERCIAL BOUNDARY** (at rated stator terminal and nominal system voltage)

BM Unit No. \_\_\_\_\_

<u>TABLE A</u>	<u>MW</u>	<u>LEAD (Mvar)</u>	<u>LAG (Mvar)</u>
<u>AT RATED MW</u>			

**REACTIVE POWER CAPABILITY AT GRID ENTRY POINT (ENGLAND AND WALES) OR HV SIDE OF RELEVANT TRANSFORMER (SCOTLAND) OR USER SYSTEM ENTRY POINT (IF EMBEDDED)**

BM Unit No. \_\_\_\_\_

<u>TABLE B</u>	<u>MW</u>	<u>LEAD (Mvar)</u>	<u>LAG (Mvar)</u>
<u>AT RATED MW</u>			
<u>AT 50% OF RATED MW</u>			
<u>AT 20% OF RATED MW</u>			
<u>AT BELOW 20% OF RATED MW</u>			
<u>AT 0% OF RATED MW</u>			

OR

*[TABLES BELOW FOR USE WHERE GRID CODE CC6.3.2(d)(ii) APPLICABLE (INCLUDING FOR POWER PARK UNITS)]*

**REACTIVE POWER CAPABILITY AT COMMERCIAL BOUNDARY** (at rated stator terminal and nominal system voltage)

<u>TABLE A</u>	<u>MW</u>	<u>LEAD (Mvar)</u>	<u>LAG (Mvar)</u>
<u>AT RATED MW</u>			

**REACTIVE POWER CAPABILITY AT NON-SYNCHRONOUS GENERATING UNIT STATOR TERMINAL** (at rated terminal voltage)

Non Synchronous Generating Unit (including Power Park Unit): Each

<u>TABLE B</u>	<u>MW</u>	<u>LEAD (Mvar)</u>	<u>LAG (Mvar)</u>
<u>AT RATED MW</u>			
<u>AT 50% OF RATED MW</u>			
<u>AT 20% OF RATED MW</u>			
<u>AT BELOW 20% OF RATED MW</u>			
<u>AT 0% OF RATED MW</u>			

**REACTIVE POWER CAPABILITY AT HV SIDE OF STEP-UP TRANSFORMER** (at rated terminal and nominal system voltage)

<u>SUMMARY TABLE C</u>	<u>RATED MW</u>	<u>LEAD (Mvar)</u>	<u>LAG (Mvar)</u>
<u>POWER PARK UNIT</u>			

[NOTE: SUMMARY TABLE C ONLY APPLICABLE TO POWER PARK MODULES]



**Part II**

**Meters and Aggregation Principles**

[BM Unit No.]

[BM] or [CCGT] Unit No	<a href="#">Metering Subsystem ID</a>	<a href="#">Outstation ID</a>	<a href="#">Channel Number</a>	<a href="#">Meter Register ID</a>	<a href="#">Measurement Quantity ID (RI or RE)</a>	Loss Adjustment Factor

**Aggregation Methodology**

[N/A]

or

[Category A/B/C/D\* aggregation principles as set out in the latest published version of the document entitled "Methodology Document for the Aggregation of Reactive Power Metering" shall apply]

\* Delete as applicable

---

**APPENDIX 3 – FURTHER DEFINITIONS**

<p><u>“Commercial Boundary”</u></p>	<p>for a <b>BM Unit</b> comprising a <b>Power Park Module</b> or <b>DC Converter</b>, the <b>Grid Entry Point</b> in England and Wales or the HV side of the 33/132 kV or 33/275 kV or 33/400 kV transformer for <b>Users</b> connected to the <b>National Electricity Transmission System</b> in Scotland or the <b>User System Entry Point</b> if <b>Embedded</b>;</p>
<p><u>“Grid Entry Point”</u></p>	<p>the meaning attributed to it in the <b>Grid Code</b>;</p>

## **CUSC – SCHEDULE 3**

### **1 Definitions and Interpretations**

- 1.1 For the purpose of this Part I and the Appendices, “**Obligatory Reactive Power Service**” means the **Mandatory Ancillary Service** referred to in **Grid Code CC 8.1** which the relevant **User** is obliged to provide (for the avoidance of doubt, as determined by any direction in force from time to time and issued by the **Authority** relieving a relevant **User** from the obligation under its **Licence** to comply with such part or parts of the **Grid Code** or any **Distribution Code** or, in the case of **The Company**, the **Transmission Licence** as may be specified in such direction) in respect of the supply of **Reactive Power** (otherwise than by means of synchronous or static compensation except in the case of a **Power Park Module** where synchronous or static compensation within the **Power Park Module** may be used to provide **Reactive Power**) and in respect of the required **Reactive Power** capability referred to in **Grid Code CC 6.3.2, which 6.3.2. This Mandatory Ancillary Service** shall comprise, in relation to a **Generating Unit, DC Converter or Power Park Module**, compliance by the relevant **User** in all respects with all provisions of the **Grid Code** applicable to it relating to that supply of **Reactive Power** and required **Reactive Power** capability, together with the provision of such despatch facilities (including the submission to **The Company** of all relevant technical, planning and other data in connection therewith) and metering facilities (meeting the requirements of Appendix 4), and upon such terms, as shall be set out in a **Mandatory Services Agreement** entered into between **The Company** and the relevant **User**.

For the avoidance of doubt, “**Obligatory Reactive Power Service**” when used in this Part I and the Appendices excludes provision of **Reactive Power** capability from **Synchronous Compensation** and from static compensation equipment (except in the case of a **Power Park Module** where synchronous or static compensation within the **Power Park Module** may be used to provide **Reactive Power**), and the production of **Reactive Power** pursuant thereto.

- 1.2 For the purpose of this Part I and the Appendices, “**Enhanced Reactive Power Service**” means the **Commercial Ancillary Service** of:-
- (a) the provision of **Reactive Power** capability of a **Generating Unit, DC Converter or Power Park Module** in excess of that which a **User** is obliged to provide from that **Generating Unit, DC Converter or Power Park Module**, under and in accordance with the **Connection Conditions** of the **Grid Code** and the production of **Reactive Power** pursuant thereto, which a **User** may agree to provide and which is capable of being made available to, and utilised by, **The Company** in accordance with the **Balancing Codes** of the **Grid Code** (or as may otherwise be agreed in writing between **The Company** and a **User**) for the purposes of voltage support on the **GB Transmission System**, upon and subject to such terms as may be agreed in writing between **The Company** and such **User**; or
  - (b) the provision of **Reactive Power** capability from **Synchronous Compensation** or from static compensation equipment (except in the case of a **Power Park Module** where **Grid Code CC8.1** specifies that such **Reactive Power** capability is a **Mandatory Ancillary Service**), and the production of **Reactive Power** pursuant thereto, which a **User** or any other person may agree to provide and which is capable of being made available to, and utilised by, **The Company** for the purposes of voltage support on the **GB Transmission System**, upon and subject to such terms as may be agreed in writing between **The Company** and such **User** or other person; or
-

SCHEDULE 3, CAP169 original

- 2.6 **Mandatory Services Agreements** have been and will continue to be entered into bilaterally between **The Company** and **Users** but it is intended that, subject as provided below, **Mandatory Services Agreements** between **The Company** and **Users** providing the **Obligatory Reactive Power Service** will be amended or (if not in existence when this Part I takes effect) concluded so as to give effect to the provisions of sub-Paragraphs 2.2 and 2.3. Subject always to sub-Paragraphs 2.8 and 4.2, **The Company** and each relevant **User** therefore agree, as soon as reasonably practicable, to amend the existing **Mandatory Services Agreement** or conclude a new **Mandatory Services Agreement** in respect of each relevant **Generating Unit, DC Converter or Power Park Module**, in order to give effect to the provisions of sub-Paragraphs 2.2 and 2.3.
- 2.7 For the avoidance of doubt, no payments referred to in this Paragraph 2 shall be payable by **The Company** to a **User** in relation to any **Generating Unit, DC Converter or Power Park Module**, unless and until the relevant **Mandatory Services Agreement** is so amended or concluded as provided in sub-Paragraph 2.6.
- 2.8 Notwithstanding the foregoing provisions of this Paragraph 2, and without prejudice to Paragraph 5, **The Company** shall only be obliged to amend or conclude any **Mandatory Services Agreement** with regard to any **Generating Unit, DC Converter or Power Park Module**, if:-
- (a) either:-
- ~~(i)~~ (i) the leading or lagging **Reactive Power** capability required of that **Generating Unit, DC Converter or Power Park Module**, in accordance with **Grid Code CC 6.3.2** (or, where the **Generating Unit, DC Converter or Power Park Module** is **Derogated Plant** of an **Embedded Exemptable Large Power Station**, the level to which, it has been **Derogated**) is 15Mvar or more (measured at the **Commercial Boundary**); ~~and or~~
- (ii) that **Generating Unit, DC Converter or Power Park Module** is at or comprises a **Large Power Station** where such required capability is less than 15Mvar (measured at the **Commercial Boundary**) and the **User** requests **The Company** in writing to so amend or conclude a **Mandatory Services Agreement** with respect thereto; and
- (b) there exists in relation to that **Generating Unit, DC Converter or Power Park Module**, metering facilities meeting the requirements of Appendix 4.
- 
- 3.2 The coming into effect of a **Market Agreement** in relation to any **Generating Unit, DC Converter or Power Park Module** shall, in respect of that **Generating Unit, DC Converter or Power Park Module**, suspend and replace for the duration thereof the provisions for payment for the **Obligatory Reactive Power Service** (if applicable) set out or referred to in Paragraph 2. In such a case, and for the avoidance of doubt, with effect from the expiry or termination of the **Market Agreement**, the provisions for payment for the **Obligatory Reactive Power Service** set out or referred to in Paragraph 2 shall in relation to that **Generating Unit, DC Converter or Power Park Module**, cease to be suspended and shall resume full force and effect.
- 
- 3.3 (c) *Submission of **Tenders***
- During the **Tender Period**, but for the avoidance of doubt not later than the **Market Day**, an interested party may submit to **The Company**:-

SCHEDULE 3, CAP169 original

- (i) in relation to any **Generating Unit, DC Converter or Power Park Module** providing the **Obligatory Reactive Power Service**, prices for and **Tendered Capability Breakpoints** relating to the provision thereof; or
- (ii) in relation to that **Generating Unit, DC Converter or Power Park Module**, a tender for provision of the **Enhanced Reactive Power Service** specified in sub-Paragraph 1.2(a) and/or (b) and/or (c); and/or
- (iii) in relation to any other **Generating Unit, DC Converter or Power Park Module** or other **Plant and Apparatus** (or other equipment), a tender for provision of the **Enhanced Reactive Power Service** specified in sub-Paragraph 1.2(b) and/or (c),

in each case in accordance with sub-Paragraph 3.3(d). All such submissions are referred to in this Part I and the Appendices as “**Tenders**”, and “**Tenderers**” shall be construed accordingly.

---

3.3

(e) *Qualification and Evaluation of Tenders*

- (i) Each **Tender** must satisfy the mandatory qualification criteria set out in Section A of Appendix 6.
- (ii) **The Company** shall evaluate and (without prejudice to sub-Paragraphs 3.3(d)(iii), (iv) and (v)) select **Tenders** (or part(s) thereof) on a basis consistent with its obligations under the **Act** the **Transmission Licence** and the **CUSC** and, subject thereto, in accordance with the evaluation criteria set out in Section B of Appendix 6. Without limitation, **The Company** reserves the right to require tests of a **Generating Unit, DC Converter or Power Park Module** or other **Plant and Apparatus** (or other equipment), on a basis to be agreed with a **Tenderer**, as part of the evaluation of a **Tender**.
- (iii) **The Company** shall use reasonable endeavours to evaluate **Tenders** within ten weeks from each **Market Day**.

---

3.3

(h) *Publication*

- (i) Within the six weeks following each **Contract Start Day**, **The Company** shall provide to all persons requesting the same the following information:-
  - (a) in respect of all **Market Agreements** then subsisting, prices and contracted **Reactive Power** capability on an individual **Tender** basis relating to the period from the immediately preceding **Contract Start Day** until the next following **Contract Start Day**;
  - (b) in respect of all **Mandatory Services Agreements** and **Market Agreements** subsisting in respect of the six month period ending on the immediately preceding **Contract Start Day**, details of utilisation of Mvarh provided by individual **BM Units** (or, where relevant, other **Plant** and/or **Apparatus** or other equipment) pursuant to the **Obligatory Reactive Power Service** and **Enhanced Reactive Power Service**;
  - (c) details of the circumstances surrounding any failure by **The Company** during the preceding six month period to perform any of its duties and responsibilities under this Paragraph 3 in the circumstances referred to in Paragraph 5; and

SCHEDULE 3, CAP169 original

- (d) any other information reasonably considered by **The Company** to be pertinent to the **Tender** process, and, to this extent, each relevant **User** consents to the disclosure by **The Company** of the information referred to in sub-sub-Paragraphs (a) and (b) above in so far as it relates to the provision of the **Obligatory Reactive Power Service** and (where applicable) an **Enhanced Reactive Power Service** from its **Generating Units**, **DC Converters or Power Park Modules** and/or other **Plant** and **Apparatus** (or other equipment).
  - (ii) Without prejudice to the provision of information pursuant to sub-Paragraph 3.3(h)(i), **The Company** further agrees to use all reasonable endeavours to provide to all persons requesting the same, within the six weeks following each **Contract Start Day**, estimates of the Mvarh absorption and generation by the **GB Transmission System**, where used for the purposes of voltage support, during the preceding six month period.
- 

- 4.2 Sub-Paragraphs 2.6 and 4.1 shall not require **The Company** or any **User** to amend or conclude a **Mandatory Services Agreement** so as to give effect to this Part I and the Appendices if and to the extent that, in respect of any **Generating Unit**, **DC Converter or Power Park Module**, **The Company** and such **User** shall have expressly agreed in writing that no payments shall be made by **The Company** to such **User** under an **Ancillary Services Agreement** for the provision of the **Obligatory Reactive Power Service** from that **Generating Unit**, **DC Converter or Power Park Module** *(as the case may be)*.
-

**APPENDIX 1 Obligatory Reactive Power Service– Default Payment Arrangements**

The provisions of this Appendix 1, as referred to in sub-Paragraph 2.2 of this Part I, shall apply to the calculation of default payments for provision of the **Obligatory Reactive Power Service** from **BM Units**. All payments shall be expressed in pounds sterling.

1. **Total Payment**

$$\text{Total Payment (PT)} = \text{PU [£ per Settlement Period per BM Unit]}$$

where, subject always to paragraphs 5 and 6 below:

PU = the utilisation payment in respect of a **BM Unit** for a **Settlement Period** determined in accordance with paragraph 2 below.

2. **Utilisation Payment**

$$\text{PU} = \text{BP}_U * U \quad [\text{£ per Settlement Period per BM Unit}]$$

Where

$$\text{BP}_U = \frac{46,270,000 * I * X}{42,054,693} \quad [\text{£/Mvarh}]$$

Where

I = defined in paragraph 3 below;

X = 1 (unless the circumstances in sub-paragraphs (a) through to ~~(d)~~ (e) apply)

And where X shall be 0.2 in all **Settlement Periods** from (and including) that in which:-

- (a) the relevant **BM Unit** (or, in relation to a **CCGT Module**, any relevant **CCGT Unit**) fails a **Reactive Test** until (and including) the **Settlement Period** in which a subsequent **Reactive Test** is passed in relation to that **BM Unit** (or **CCGT Unit** (as the case may be)); or
- (b) the **User** fails (other than pursuant to an instruction given by **The Company** or as permitted by the **Grid Code**) to set the automatic voltage regulator of the **BM Unit** (or, in relation to a **CCGT Module**, any relevant **CCGT Unit**) to a voltage following mode until (and including) the **Settlement Period** in which the **User** notifies **The Company** that the automatic voltage regulator is so set; or
- (c) the **BM Unit** fails to comply with a **Reactive Despatch Instruction** due to the fact that the **BM Unit** (or, in relation to a **CCGT Module**, any relevant **CCGT Unit**) is unable to increase and/or decrease its Mvar output (other than as a direct result of variations in **System** voltage) until (and including) the **Settlement Period** in which the **User** notifies **The Company** that the **BM Unit** is so able to comply; or

*SCHEDULE 3, CAP169 original*

- (d) the **BM Unit** fails to have a Mvar range which includes the ability to provide zero Mvar at the **Commercial Boundary** until (and including) the **Settlement Period** in which the **User** notifies **The Company** that the **BM Unit** has or once more has such range; ~~and or~~
  - (e) a **Pre-Connection Reactive Despatch Network Restriction** affects the relevant **BM Unit** until (and including) the **Settlement Period** in which notification is given to **The Company** pursuant to the **Grid Code** that such **Pre-Connection Reactive Despatch Network Restriction** is no longer affecting that **BM Unit**; and
- U = defined in Section 1 of Appendix 3

---

**Appendix 1 Obligatory Reactive Power Service – Default Payment Arrangements**

- 5.2 Before any demonstration of compliance referred to in sub-paragraph 5.1 above, it shall be necessary for the **User** to demonstrate to **The Company's** reasonable satisfaction, having regard to industry practice, that the **BM Unit's** (or, in the case of a **CCGT Module**, each relevant **CCGT Unit's**) **Excitation System**, and in particular the under-excitation limiter, or in the case of a **Power Park Module** or **DC Converter**, the continuously acting automatic voltage control system required to provide control of the voltage or zero transfer of **Reactive Power**, has been successfully commissioned and complies with the provisions of **Grid Code CC 6.3.8**.



**Appendix 2 Obligatory Reactive Power Service and Enhanced Reactive Power Services – Market Payment Mechanism**

The provisions of this Appendix 2, as referred to in sub-Paragraph 3.3(d)(i) of this Part I, shall apply to the calculation of payments in respect of **Tenders** comprising prices for and **Tendered Capability Breakpoints** relating to the **Obligatory Reactive Power Service** and in respect of **Tenders** comprising terms for the provision of the **Enhanced Reactive Power Services** specified in sub-Paragraph 1.2(a) of this Part I, in each case in respect of **BM Units**. All payments shall be expressed in pounds sterling. All algebraic terms contained in this Appendix 2 shall bear the meanings set out in paragraph 1 below unless the context otherwise requires.

1. **Definitions**

For the purposes of this Appendix 2, unless the context otherwise requires, the following terms shall have the following meanings:-

CA1,CA2 and CA3	=	the available capability prices (expressed to apply to both leading and lagging) (£/Mvar/h) (as more particularly described in paragraph 2 of Appendix 5) as specified in the relevant <b>Market Agreement</b> ;
CS1,CS2 and CS3	=	the synchronised capability prices (expressed to apply to both leading and lagging) (£/Mvar/h) (as more particularly described in paragraph 2 of Appendix 5) as specified in the relevant <b>Market Agreement</b> ;
CU1,CU2 and CU3	=	the utilisation prices (expressed to apply to both leading and lagging) (£/Mvarh) (as more particularly described in paragraph 2 of Appendix 5) as specified in the relevant <b>Market Agreement</b> ;
K	=	in respect of <b>CCGT <u>Modules and Power Park</u> Modules</b> , the relevant configuration factor as specified in the relevant <b>Market Agreement</b> , otherwise 1;
$Q_{lead}$	=	defined in Section 2 of Appendix 3;
$Q_{lag}$	=	defined in Section 2 of Appendix 3;
$QM_{ij}$	=	<b>BM Unit Metered Volume</b> (as defined in the <b>Balancing and Settlement Code</b> );
Q1, Q2 and Q3	=	the contracted capability breakpoints (expressed to apply to both leading and lagging) in whole Mvar as may be specified in the relevant <b>Market Agreement</b> , where:  (i) $Q1 = TQ1$ , $Q2 = TQ2$ and $Q3 = QC$ where $TQ2 < QC \leq TQ3$  (ii) $Q1 = TQ1$ , $Q2 = QC$ $Q3 = null$

where  $TQ1 < QC \leq TQ2$

- (iii)  $Q1 = QC$ ,  
 $Q2 = \text{null}$   
 $Q3 = \text{null}$   
where  $0 \leq QC \leq TQ1$

SPD	=	the duration of a <b>Settlement Period</b> , being 0.5;
TQ1, TQ2 and TQ3	=	defined in Appendix 5;
$U_{\text{lead}}$	=	defined in Section 1 of Appendix 3;
$U_{\text{lag}}$	=	defined in Section 1 of Appendix 3;
V	=	the system voltage range performance factor (expressed to apply to both leading and lagging) as calculated in accordance with the formulae set out in the relevant <b>Market Agreement</b> , otherwise 1;
$MEL_i(t)$	=	<b>Maximum Export Limit</b> (as defined in the <b>Balancing and Settlement Code</b> ).

## 2. Total Payment

Total Payment (PTM) = PUM + PCA + PCS *[£ per Settlement Period per BM Unit]*

where, subject always to paragraphs 6, 7 and 8 below:

- PUM = the utilisation payment in respect of a **BM Unit** for a **Settlement Period** determined in accordance with paragraph 3 below;
- PCA = the available capability payment in respect of a **BM Unit** for a **Settlement Period** determined in accordance with paragraph 4 below; and
- PCS = the synchronised capability payment in respect of a **BM Unit** for a **Settlement Period** determined in accordance with paragraph 5 below.

Provided always that PTM shall be 0 in all **Settlement Periods** from and including that in which:-

- (a) the relevant **BM Unit** (or, in relation to a **CCGT Module**, any relevant **CCGT Unit**) fails a **Reactive Test** or a **Contract Test** until (and including) the **Settlement Period** in which a subsequent **Reactive Test** or **Contract Test** (as the case may be) is passed in relation to that **BM Unit** (or **CCGT Unit** (as the case may be)); or
- (b) the **User** fails (other than pursuant to an instruction given by **The Company** or as permitted by the **Grid Code**) to set the automatic voltage regulator of the **BM Unit** (or, in relation to a **CCGT Module**, any relevant **CCGT Unit**) to a voltage following mode until (and including) the **Settlement Period** in which the **User** notifies **The Company** that the automatic voltage regulator is so set; or
- (c) the **BM Unit** fails to comply with a **Reactive Despatch Instruction** due to the fact that the **BM Unit** (or, in relation to a **CCGT Module**, any relevant **CCGT Unit**) is unable to increase and/or decrease its Mvar **Output** (other than as a direct result of variations in

SCHEDULE 3, CAP169 original

**System** voltage) until (and including) the **Settlement Period** in which the **User** notifies **The Company** that the **BM Unit** is so able to comply; or

- (d) the **BM Unit** fails to have a Mvar range which includes the ability to provide zero Mvar at the **Commercial Boundary** until (and including) the **Settlement Period** in which the **User** notifies **The Company** that the **BM Unit** has or once more has such range; or
- (e) a **Pre-Connection Reactive Despatch Network Restriction** affects the relevant **BM Unit** until (and including) the **Settlement Period** in which notification is given to **The Company** pursuant to the **Grid Code** that such **Pre-Connection Reactive Despatch Network Restriction** is no longer affecting that **BM Unit**.

**Appendix 3 Section 2 Reactive Power Capability Data and Redeclarations**

This Section 2 of Appendix 3 specifies the technical data to be used to determine the capability payments to be made in accordance with Appendix 2.

1. For the purposes thereof, the following terms shall have the following meanings:-

$$Q_{\text{lead}} = \min (QR_{\text{lead}}, QC_{\text{lead}}) \quad [Mvar]$$

$$Q_{\text{lag}} = \min (QR_{\text{lag}}, QC_{\text{lag}}) \quad [Mvar]$$

where

QC = as specified in the relevant **Mandatory Services Agreement** and/or **Market Agreement**, being either (1) the high voltage value (specified in whole Mvar) equivalent at the **Commercial Boundary** to the low voltage Mvar capability (leading or lagging) of the relevant **BM Unit** as described in paragraph 2 below, or (2) where applicable, the high voltage Mvar capability (leading or lagging) of the relevant **BM Unit** as described in paragraph 2 below, in each case representing the capability to supply continuously leading or lagging Mvar (as the case may be);

QR = as determined in accordance with the relevant **Mandatory Services Agreement** and/or **Market Agreement**, being, in relation to a **Settlement Period**, either (1) the high voltage value (specified in whole Mvar) equivalent to the redeclared low voltage Mvar capability (leading or lagging) or (2) the redeclared high voltage Mvar capability (leading or lagging), in each case of the relevant **BM Unit** (or, in the absence of such redeclaration, such high voltage value reasonably determined by **The Company** as a result of monitoring and/or testing as provided in the relevant **Mandatory Services Agreement** and/or **Market Agreement**), and  $QR_{\text{lead}}$  and  $QR_{\text{lag}}$  shall be construed accordingly.

2. (a) In respect of capability payments made in accordance with Appendix 1:-

- (i) QC shall be the low voltage (or high voltage, as the case may be) capability required to ~~provide~~be provided under and in accordance with the **Connection Conditions** of the **Grid Code** (where applicable, as determined by any direction in force from time to time and issued by the **Authority** relieving the relevant **User** from the obligation under its **Licence** to comply with such part or parts of the **Grid Code** as may be specified therein); and
- (ii) QC and QR shall represent the high voltage (or high voltage value equivalent) capability (or redeclared capability) at **Rated MW** at the **Commercial Boundary**.

#### **Appendix 4 Metering**

- 2.4 Where the configuration of the **Metering System** is such that:-
- 2.4.1 Mvarh import and export values for the **BM Unit** are not measured at the **Commercial Boundary**; and/or
  - 2.4.2 Mvarh import and export values for the **BM Unit** are measured by more than one **Meter**; and/or
  - 2.4.3 the Mvarh import and export values for the **BM Unit** are measured by a **Meter** which also measures the Mvarh import and export values of one or more other **Generating Units, DC Converters, Power Park Modules, Plant and Apparatus** or other equipment,
- 

#### **Appendix 5 Submission of Tenders**

##### **4. Other Technical Information**

A **User** shall submit with a **Tender** such other technical information as reasonably directed by **The Company** in accordance with sub-Paragraph 3.3 (b)(i) of this Part I. Such information may include (without limitation):-

- 4.1 in relation to a **Tender** for the **Enhanced Reactive Power Service** specified in sub-Paragraph 1.2 (a) of this Part I, details of the capability of the **Generating Unit, DC Converter or Power Park Module** (as the case may be) to provide **Reactive Power** either:-
- (a) in the case of a **Generating Unit**, at the generator stator terminals; or
  - (b) in the case of a **Non-Synchronous Generating Unit, DC Converter or Power Park Module**, either at the **Grid Entry Point** in England and Wales or at the HV side of the 33/132 kV or 33/275 kV or 33/400 kV transformer for **Users** connected to the **National Electricity Transmission System** in Scotland or the **User System Entry Point** if **Embedded**,
- in each case by reference to the **Generator Performance Chart** submitted in accordance with **Operating Condition** 2.4.2 of the **Grid Code**, which capability must represent the true operating characteristics of that **Generating Unit, DC Converter or Power Park Module**; and
- 4.2 details of the system voltage range over which the **User** proposes to make available from the **Generating Unit, DC Converter or Power Park Module** such **Enhanced Reactive Power Service** (and in each case any restrictions thereto); and



**Appendix 6 Qualification and Evaluation Criteria**

**Section A – Qualification Criteria**

1.2 in relation to a **Tender** for provision of any other **Enhanced Reactive Power Service**, the leading and/or lagging capability (as the case may be) comprised therein must ~~be at least 15 Mvar leading and/or 15 Mvar lagging (as the case may be) (as measured at the Commercial Boundary)~~ meet the requirements of sub-Paragraph 2.8(a) of this Part I; and

---

2.1 in relation to a **Generating Unit, DC Converter or Power Park Module** providing the **Obligatory Reactive Power Service**, a comparison with the default payment arrangements for that **Generating Unit, DC Converter or Power Park Module** including the effect (if any) of the balance of tendered capability and utilisation prices as a hedge against forecast costs of that **Generating Unit, DC Converter or Power Park Module** pursuant to the default payment arrangements;

---

3.5 in relation to a **Generating Unit, DC Converter or Power Park Module**, forecast MW output and MW availability;

---

3.8 the capability (if any) of a **Generating Unit, DC Converter or Power Park Module** to provide voltage support services when not providing **Active Power** (for example pumped storage plant operating in spin-gen mode or when pumping and open cycle gas turbine plant when declutched and operating in **Synchronous Compensation** mode);

**Appendix 7 Charging Principles**

1. The totality of payments that would be made pursuant to the default payment arrangements in the absence of **Market Agreements** shall be based and founded upon the following variable costs (actual or estimated) incurred or to be incurred in respect of, and aggregated across, all **Generating Units, DC Converters and Power Park Modules** providing the **Obligatory Reactive Power Service**:-
  - 1.1 the additional heat losses incurred as a consequence of producing **Reactive Power**, measured at the high voltage side of the generator/transformer terminals, the calculation of such heat losses to take account of the square law relationship between the electric current and the additional heat losses incurred; and
  - 1.2 maintenance costs incurred as a direct result of **Reactive Power** output (including a sum in respect of any reduction in the working life of **Generating Unit, DC Converter or Power Park Module** components consequent upon **Reactive Power** output).
2. For the avoidance of doubt, and without limitation, the totality of payments referred to in paragraph 1 above shall not take into account in respect of any **Generating Unit, DC Converter or Power Park Module** providing the **Obligatory Reactive Power Service** the fixed costs incurred in achieving initial compliance with the relevant provisions of the **Grid Code**.



## **Appendix 8 Calculation of Reactive Power Capability at the Commercial Boundary**

### **Part 1**

In accordance with the terms of the **Mandatory Services Agreement**, ~~these~~[where applicable the formulae in this Part 1](#) will be used to convert **Reactive Power** capability of a **BM Unit** at the generator stator terminals to the capability at the **Commercial Boundary**.

$$Q_{lead} = (Q_{Glead} + Q_U) + \left[ \frac{[(P_G - P_U)^2 + (Q_{Glead} + Q_U)^2] * F * X_t}{100. MVA_X} \right] + Q_{ts}$$

Where the **BM Unit** has a **Reactive Power** capability (leading), this shall be expressed as a positive integer. Where the **BM Unit** does not have a **Reactive Power** capability (leading),  $Q_{lead}$  and/or  $Q_{Glead}$  shall be the minimum **Reactive Power** capability (lagging) expressed as a negative integer or zero.

$$Q_{lag} = (Q_{Glag} - Q_U) - \left[ \frac{[(P_G - P_U)^2 + (Q_{Glag} - Q_U)^2] * F * X_t}{100. MVA_X} \right] - Q_{ts}$$

Where the **BM Unit** has a **Reactive Power** capability (lagging), this shall be expressed as a positive integer. Where the **BM Unit** does not have a **Reactive Power** capability (lagging),  $Q_{lag}$  and/or  $Q_{Glag}$  shall be the minimum **Reactive Power** capability (leading) expressed as a negative integer or zero.

Where:

- $Q_{lead}$  = the **Reactive Power** capability (leading) of the **BM Unit** at **Rated MW** at the **Commercial Boundary** in Mvar;
- $Q_{lag}$  = the **Reactive Power** capability (lagging) of the **BM Unit** at **Rated MW** at the **Commercial Boundary** in Mvar;
- $P_G$  = **Rated MW** referred to in Schedule 1 of **Grid Code DRC**;
- $P_U$  = normal auxiliary load (**Active Power**) supplied by the **BM Unit** at **Rated MW** referred to in Schedule 1 of **Grid Code DRC** in MW;
- $Q_U$  = normal auxiliary lagging load (**Reactive Power**) supplied by the **BM Unit** at **Rated MW** referred to in Schedule 1 of **Grid Code DRC** in Mvar;
- $X_t$  = positive sequence reactance, nominal tap, of the **BM Unit** step-up transformer in percentage of rating as referred to in Schedule 1 of **Grid Code DRC**;
- $F$  = the factor (if any) identified as such in the **Mandatory Services Agreement** representing the number of station transformers, otherwise 1;
- $Q_{Glag}$  = the **Reactive Power** capability (lagging) of the **BM Unit** at **Rated MW** at the generator stator terminals, [where applicable](#) as set out in Table B of Appendix 1, Section A, Part I of the **Mandatory Services Agreement** or as redeclared by the **User** pursuant to **Grid Code BC**;
- $Q_{Glead}$  = the **Reactive Power** capability (leading) of the **BM Unit** at **Rated MW** at the generator stator terminals, [where applicable](#) as set out in Table B of Appendix 1, Section A, Part I of the **Mandatory Services Agreement** or as redeclared by the **User** pursuant to **Grid Code BC**;
- $Q_{ts}$  = the relevant reactive load applicable to each of the relevant **BM Unit** shown in the relevant table in the **Mandatory Services Agreement**, the summation of which represents the lagging reactive load in Mvar taken by a **Trading Unit** calculated in accordance with the values for **Demand (Active Power)** and **Power Factor** referred to in **Grid Code PC.A.4.3.1(a)** or **Grid Code PC.A.5.2.2(a)** (as the case may be), or as agreed between **The Company** and the **User** from time to time (and where such load is leading,  $Q_{ts}$  will be negative);

CUSC Schedule 3 - CAP169 original

$MVA_x$  = **BM Unit** step-up transformer rated MVA referred to in Schedule 1 of **Grid Code DRC**.

N.B. All of the above factors referred to in **Grid Code DRC** shall be expressed in such units as are specified in **Grid Code DRC** and to the same number of significant figures as also specified therein (as varied from time to time).

## **Part 2**

In accordance with the terms of the **Mandatory Services Agreement**, where applicable the formulae in Section 1 of this Part 2 will be used by **The Company** to convert **Reactive Power** capability of a **CCGT Unit** at the generator stator terminals to the capability at the HV side of the **Generating Unit** step-up transformer, and the formulae in Section 2 of this Part 2 will be used to calculate the **Reactive Power** capability of the **BM Unit** at the **Commercial Boundary**.

### **Section 1**

$$CQ_{\text{lead}} = (Q_{\text{Glead}} + Q_{\text{u}}) + \left[ \frac{[(P_{\text{G}} - P_{\text{U}})^2 + (Q_{\text{Glead}} + Q_{\text{U}})^2] * F * X_{\text{t}}}{100.MVA_{\text{x}}} \right]$$

Where the **CCGT Unit** has a **Reactive Power** capability (leading), this shall be expressed as a positive integer. Where the **CCGT Unit** does not have a **Reactive Power** capability (leading),  $Q_{\text{lead}}$  and/or  $Q_{\text{Glead}}$  shall be the minimum **Reactive Power** capability (lagging) expressed as a negative integer or zero.

$$CQ_{\text{lag}} = (Q_{\text{Glag}} - Q_{\text{u}}) - \left[ \frac{[(P_{\text{G}} - P_{\text{U}})^2 + (Q_{\text{Glag}} - Q_{\text{U}})^2] * F * X_{\text{t}}}{100.MVA_{\text{x}}} \right]$$

Where the **CCGT Unit** has a **Reactive Power** capability (lagging), this shall be expressed as a positive integer. Where the **CCGT Unit** does not have a **Reactive Power** capability (lagging),  $Q_{\text{lag}}$  and/or  $Q_{\text{Glag}}$  shall be the minimum **Reactive Power** capability (leading) expressed as a negative integer or zero.

Where:

$CQ_{\text{lead}}$	=	the <b>Reactive Power</b> capability (leading) of the <b>CCGT Unit</b> at <b>Rated MW</b> at the HV side of the <b>Generating Unit</b> step-up transformer in Mvar;
$CQ_{\text{lag}}$	=	the <b>Reactive Power</b> capability (lagging) of the <b>CCGT Unit</b> at <b>Rated MW</b> at the HV side of the <b>Generating Unit</b> step-up transformer in Mvar;
$P_{\text{G}}$	=	<b>Rated MW</b> of a <b>CCGT Unit</b> referred to in Schedule 1 of <b>Grid Code DRC</b> ;
$P_{\text{U}}$	=	normal auxiliary load ( <b>Active Power</b> ) supplied by the <b>CCGT Unit</b> at <b>Rated MW</b> referred to in Schedule 1 of <b>Grid Code DRC</b> in MW;
$Q_{\text{U}}$	=	normal auxiliary lagging load ( <b>Reactive Power</b> ) supplied by the <b>CCGT Unit</b> at <b>Rated MW</b> referred to in Schedule 1 of <b>Grid Code DRC</b> in Mvar;
$F$	=	the factor (if any) identified as such in the <b>Mandatory Services Agreement</b> representing the number of station transformers, otherwise 1;
$X_{\text{t}}$	=	positive sequence reactance, nominal tap, of the <b>CCGT Unit</b> step-up transformer in percentage of rating as referred to in Schedule 1 of <b>Grid Code DRC</b> ;
$Q_{\text{Glag}}$	=	the <b>Reactive Power</b> capability (lagging) of the <b>CCGT Unit</b> at <b>Rated MW</b> at the <b>User</b> stator terminals as set out in Table B of Appendix 1, Part I of the <b>Mandatory Services Agreement</b> or as redeclared by the <b>User</b> pursuant to <b>Grid Code BC</b> ;
$Q_{\text{Glead}}$	=	the <b>Reactive Power</b> capability (leading) of the <b>CCGT Unit</b> at <b>Rated MW</b> at the <b>User</b> stator terminals as set out in Table B of Appendix 1, Part I of the <b>Mandatory Services Agreement</b> or as redeclared by the <b>User</b> pursuant to <b>Grid Code BC</b> ;
$MVA_{\text{x}}$	=	<b>Generating Unit</b> step-up transformer rated MVA referred to in Schedule 1 of <b>Grid Code DRC</b> .

### **Section 2**

CUSS Schedule 3 - CAP169 original

$$Q_{lead} = \left( \sum_n^{CCGTunits} CQ_{lead} \right) + Q_{ts}$$

$$Q_{lag} = \left( \sum_n^{CCGTunits} CQ_{lag} \right) - Q_{ts}$$

Where

$Q_{lead}$  = the **Reactive Power** capability (leading) of the **BM Unit** at the **Commercial Boundary** in Mvar;

$\sum_n^{CCGTunits}$  = the summation over each relevant **CCGT Unit**;

$Q_{lag}$  = the **Reactive Power** capability (lagging) of the **BM Unit** at the **Commercial Boundary** in Mvar;

$Q_{ts}$  = the relevant reactive load applicable to each of the **BM Units** shown in the relevant table in the **Mandatory Services Agreement**, the summation of which represents the lagging reactive load in Mvar taken by a **Trading Unit** calculated in accordance with the values for **Demand (Active Power)** and **Power Factor** referred to in **Grid Code PC.A.4.3.1(a)** or **Grid Code PC.A.5.2.2(a)** (as the case may be), or as agreed between **The Company** and the **User** from time to time (and where such load is leading,  $Q_{ts}$  will be negative).

N.B. All of the above factors referred to in **Grid Code DRC** shall be expressed in such units as are specified in **Grid Code DRC** and to the same number of significant figures as also specified therein (as varied from time to time).

### Part 3

In accordance with the terms of the **Mandatory Services Agreement**, where applicable the formulae in Section 1 of this Part 3 will be used by **The Company** to convert **Reactive Power** capability of a **Power Park Unit** at the generator stator terminals to the capability at the HV side of the **Generating Unit** step-up transformer, and the formulae in Section 2 of this Part 3 will be used to calculate the **Reactive Power** capability of the **Power Park Module** at the **Commercial Boundary**.

#### Section 1

$$CQ_{\text{lead}} = (Q_{\text{Glead}} + Q_u) + \left[ \frac{[(P_G - P_U)^2 + (Q_{\text{Glead}} + Q_U)^2] * F * X_t}{100.MVA_x} \right]$$

Where the **Power Park Unit** has a **Reactive Power** capability (leading), this shall be expressed as a positive integer. Where the **Power Park Unit** does not have a **Reactive Power** capability (leading),  $Q_{\text{lead}}$  and/or  $Q_{\text{Glead}}$  shall be the minimum **Reactive Power** capability (lagging) expressed as a negative integer or zero.

$$CQ_{\text{lag}} = (Q_{\text{Glag}} - Q_u) - \left[ \frac{[(P_G - P_U)^2 + (Q_{\text{Glag}} - Q_U)^2] * F * X_t}{100.MVA_x} \right]$$

Where the **Power Park Unit** has a **Reactive Power** capability (lagging), this shall be expressed as a positive integer. Where the **Power Park Unit** does not have a **Reactive Power** capability (lagging),  $Q_{\text{lag}}$  and/or  $Q_{\text{Glag}}$  shall be the minimum **Reactive Power** capability (leading) expressed as a negative integer or zero.

Where:

- $CQ_{\text{lead}}$  = the **Reactive Power** capability (leading) of the **Power Park Unit** at **Rated MW** at the HV side of the **Generating Unit** step-up transformer in Mvar;
- $CQ_{\text{lag}}$  = the **Reactive Power** capability (lagging) of the **Power Park Unit** at **Rated MW** at the HV side of the **Generating Unit** step-up transformer in Mvar;
- $P_G$  = **Rated MW** of a **Power Park Unit** referred to in Schedule 1 of **Grid Code DRC**;
- $P_U$  = normal auxiliary load (**Active Power**) supplied by the **Power Park Unit** at **Rated MW** referred to in Schedule 1 of **Grid Code DRC** in MW;
- $Q_U$  = normal auxiliary lagging load (**Reactive Power**) supplied by the **Power Park Unit** at **Rated MW** referred to in Schedule 1 of **Grid Code DRC** in Mvar;
- $F$  = the factor (if any) identified as such in the **Mandatory Services Agreement** representing the number of **Power Park Units** transformers, otherwise 1;
- $X_t$  = positive sequence reactance, nominal tap, of the **Power Park Unit** step-up transformer in percentage of rating as referred to in Schedule 1 of **Grid Code DRC**;
- $Q_{\text{Glag}}$  = the **Reactive Power** capability (lagging) of the **Power Park Unit** at **Rated MW** at the **User** stator terminals as set out in Table B of Appendix 1, Part I of the **Mandatory Services Agreement** or as redeclared by the **User** pursuant to **Grid Code BC**;
- $Q_{\text{Glead}}$  = the **Reactive Power** capability (leading) of the **Power Park Unit** at **Rated MW** at the **User** stator terminals as set out in Table B of Appendix 1, Part I of the **Mandatory Services Agreement** or as redeclared by the **User** pursuant to **Grid Code BC**;

MVA<sub>x</sub> = Generating Unit step-up transformer rated MVA referred to in Schedule 1 of Grid Code DRC.

## Section 2

$$Q_{lead} = \left( \sum_n^{PPUnits} C Q_{lead} \right) + Q_{ts} + \left[ \frac{[(P1_G - P1_U)^2 + (Q1_{Glead} + Q1_U)^2] * F1 * X1_t}{100.MVA1_x} \right]$$

$$Q_{lag} = \left( \sum_n^{PPUnits} C Q_{lag} \right) - Q_{ts} - \left[ \frac{[(P1_G - P1_U)^2 + (Q1_{Glag} - Q1_U)^2] * F1 * X1_t}{100.MVA1_x} \right]$$

Where

Q<sub>lead</sub> = the Reactive Power capability (leading) of the Power Park Module at the Commercial Boundary in Mvar;

$\sum_n^{PPUnits}$  = the summation over each relevant Power Park Unit;

Q<sub>lag</sub> = the Reactive Power capability (lagging) of the BM Unit at the Commercial Boundary in Mvar;

Q<sub>ts</sub> = [the relevant reactive load applicable to the Power Park Module shown in the relevant table in the Mandatory Services Agreement, the summation of which represents the lagging reactive load in Mvar taken by a Trading Unit calculated in accordance with the values for Demand (Active Power) and Power Factor referred to in Grid Code PC.A.4.3.1(a) or Grid Code PC.A.5.2.2(a) (as the case may be), or as agreed between The Company and the User from time to time (and where such load is leading, Q<sub>ts</sub> will be negative).]

$$P1_G = \sum_n^{PPUnits} P_G$$

$$P1_U = \sum_n^{PPUnits} P_U$$

$$Q1_{Glag} = \sum_n^{PPUnits} Q_{Glag}$$

CUSC Schedule 3 - CAP169 original

$$Q_{Glead}^{1} = \sum_n^{PPUnits} Q_{Glead}$$

$F1$  = the factor (if any) identified as such in the **Mandatory Services Agreement** representing the number of station transformers, otherwise 1;

$X1_t$  = positive sequence reactance, nominal tap, of the **Power Park Module** step up transformer in percentage of rating as referred to in Schedule 1 of **Grid Code DRC**

$MVA1_x$  = **Power Park Module** step-up transformer rated MVA referred to in Schedule 1 of **Grid Code DRC**

N.B. All of the above factors referred to in **Grid Code DRC** shall be expressed in such units as are specified in **Grid Code DRC** and to the same number of significant figures as also specified therein (as varied from time to time).

**PART B: LEGAL TEXT TO MODIFY THE CUSC – WGAA1**

In addition to the changes proposed for the original, WGAA1 will require introduction of an additional definition for Temporary Enduring Reactive Despatch Network Restriction, and an alternative proposal for the changes to Schedule 3 (appendix 1 and 2). For the purposes of the consultation document only the additional changes are included, all other changes (not repeated here) in Part A of the Consultation Document Volume 2 also being applicable.

**The following pages show the marked up changes for the following sections of the CUSC:**

1. Section 11
2. Schedule 3

Please note, only the specific clauses requiring amendment have been

Changes are marked as outlined in the table below:

<b>Legend:</b>
<u>Insertion</u>
<del>Deletion</del>



**WGAA1 – Proposed drafting CUSC**

<p><b><u>“Temporary Enduring Reactive Despatch Network Restriction”</u></b></p>	<p>means, with respect to any <b><u>Embedded Generating Unit, Embedded Power Park Module or DC Converter</u></b> at an <b><u>Embedded DC Converter Station</u></b>, a <b><u>Reactive Despatch Network Restriction</u></b> (not being a <b><u>Pre-Connection Reactive Despatch Network Restriction</u></b>) which results in the <b><u>Generating Unit, Power Park Module or DC Converter</u></b> being unable to comply with a <b><u>Reactive Despatch Instruction</u></b> from <b><u>The Company</u></b> to provide 0 Mvar at the <b><u>Commercial Boundary</u></b> and which either:</p> <ul style="list-style-type: none"><li>(a) <u>has been in place at the relevant time for more than 12 consecutive months; or</u></li><li>(b) <u>when combined with any one or more previous <b><u>Reactive Despatch Network Restrictions</u></b> (including for the avoidance of doubt any <b><u>Pre-Connection Reactive Despatch Network Restriction</u></b>), has affected the relevant <b><u>Generating Unit, Power Park Module or DC Converter</u></b> for an aggregate period of more than 12 months in any consecutive 24 month period;</u></li></ul>
---	---

**Schedule 3, APPENDIX 1****Obligatory Reactive Power Service**  
**– Default Payment Arrangements**

The provisions of this Appendix 1, as referred to in sub-Paragraph 2.2 of this Part I, shall apply to the calculation of default payments for provision of the **Obligatory Reactive Power Service** from **BM Units**. All payments shall be expressed in pounds sterling.

1. **Total Payment**

Total Payment (PT) = PU [*£ per Settlement Period per BM Unit*]

where, subject always to paragraphs 5 and 6 below:

PU = the utilisation payment in respect of a **BM Unit** for a **Settlement Period** determined in accordance with paragraph 2 below.

2. **Utilisation Payment**

PU =  $BP_U * U$  [*£ per Settlement Period per BM Unit*]

Where

$$BP_U = \frac{46,270,000 * I * X}{42,054,693} \quad [£/Mvarh]$$

Where

I = defined in paragraph 3 below;

X = 1 (unless the circumstances in sub-paragraphs (a) through to (e) ~~(d)~~ ~~(e)~~ apply)

And where X shall be 0.2 in all **Settlement Periods** from (and including) that in which:-

- (a) the relevant **BM Unit** (or, in relation to a **CCGT Module**, any relevant **CCGT Unit**) fails a **Reactive Test** until (and including) the **Settlement Period** in which a subsequent **Reactive Test** is passed in relation to that **BM Unit** (or **CCGT Unit** (as the case may be)); or
- (b) the **User** fails (other than pursuant to an instruction given by **The Company** or as permitted by the **Grid Code**) to set the automatic voltage regulator of the **BM Unit** (or, in relation to a **CCGT Module**, any relevant **CCGT Unit**) to a voltage following mode until (and including) the **Settlement Period** in which the **User** notifies **The Company** that the automatic voltage regulator is so set; or

- (c) the **BM Unit** fails to comply with a **Reactive Despatch Instruction** due to the fact that the **BM Unit** (or, in relation to a **CCGT Module**, any relevant **CCGT Unit**) is unable to increase and/or decrease its Mvar output (other than as a direct result of variations in **System** voltage) until (and including) the **Settlement Period** in which the **User** notifies **The Company** that the **BM Unit** is so able to comply; or
  - (d) the **BM Unit** fails to have a Mvar range which includes the ability to provide zero Mvar at the **Commercial Boundary** until (and including) the **Settlement Period** in which the **User** notifies **The Company** that the **BM Unit** has or once more has such range; ~~and~~ or
  - (e) the **BM Unit** is affected by either a **Pre-Connection Reactive Despatch Network Restriction** or a **Temporary Enduring Reactive Despatch Network Restriction**, in each case until (and including) the **Settlement Period** in which notification is given to **The Company** pursuant to the **Grid Code** that such **Reactive Despatch Network Restriction** is no longer affecting that **BM Unit**; and
- U = defined in Section 1 of Appendix 3

**Schedule 3, Appendix 2****Obligatory Reactive Power Service and Enhanced Reactive Power Services – Market Payment Mechanism**

The provisions of this Appendix 2, as referred to in sub-Paragraph 3.3(d)(i) of this Part I, shall apply to the calculation of payments in respect of **Tenders** comprising prices for and **Tendered Capability Breakpoints** relating to the **Obligatory Reactive Power Service** and in respect of **Tenders** comprising terms for the provision of the **Enhanced Reactive Power Services** specified in sub-Paragraph 1.2(a) of this Part I, in each case in respect of **BM Units**. All payments shall be expressed in pounds sterling. All algebraic terms contained in this Appendix 2 shall bear the meanings set out in paragraph 1 below unless the context otherwise requires.

**1. Definitions**

For the purposes of this Appendix 2, unless the context otherwise requires, the following terms shall have the following meanings:-

CA1,CA2 and CA3	=	the available capability prices (expressed to apply to both leading and lagging) (£/Mvar/h) (as more particularly described in paragraph 2 of Appendix 5) as specified in the relevant <b>Market Agreement</b> ;
CS1,CS2 and CS3	=	the synchronised capability prices (expressed to apply to both leading and lagging) (£/Mvar/h) (as more particularly described in paragraph 2 of Appendix 5) as specified in the relevant <b>Market Agreement</b> ;
CU1,CU2 and CU3	=	the utilisation prices (expressed to apply to both leading and lagging) (£/Mvarh) (as more particularly described in paragraph 2 of Appendix 5) as specified in the relevant <b>Market Agreement</b> ;
K	=	in respect of <b>CCGT Modules</b> , the relevant configuration factor as specified in the relevant <b>Market Agreement</b> , otherwise 1;
$Q_{lead}$	=	defined in Section 2 of Appendix 3;
$Q_{lag}$	=	defined in Section 2 of Appendix 3;
$QM_{ij}$	=	<b>BM Unit Metered Volume</b> (as defined in the <b>Balancing and Settlement Code</b> );
Q1, Q2 and Q3	=	the contracted capability breakpoints (expressed to apply to both leading and lagging) in whole Mvar as may be specified in the relevant <b>Market Agreement</b> , where: <ul style="list-style-type: none"> <li>(i) <math>Q1 = TQ1,</math> <math>Q2 = TQ2</math> and <math>Q3 = QC</math> where <math>TQ2 &lt; QC \leq TQ3</math></li> <li>(ii) <math>Q1 = TQ1,</math> <math>Q2 = QC</math> <math>Q3 = null</math></li> </ul>

where  $TQ1 < QC \leq TQ2$

- (iii)  $Q1 = QC$ ,  
 $Q2 = \text{null}$   
 $Q3 = \text{null}$   
 where  $0 \leq QC \leq TQ1$

SPD	=	the duration of a <b>Settlement Period</b> , being 0.5;
TQ1, TQ2 and TQ3	=	defined in Appendix 5;
$U_{\text{lead}}$	=	defined in Section 1 of Appendix 3;
$U_{\text{lag}}$	=	defined in Section 1 of Appendix 3;
V	=	the system voltage range performance factor (expressed to apply to both leading and lagging) as calculated in accordance with the formulae set out in the relevant <b>Market Agreement</b> , otherwise 1;
$MEL_i(t)$	=	<b>Maximum Export Limit</b> (as defined in the <b>Balancing and Settlement Code</b> ).

## 2. Total Payment

Total Payment (PTM) = PUM + PCA + PCS *[£ per Settlement Period per BM Unit]*

where, subject always to paragraphs 6, 7 and 8 below:

- PUM = the utilisation payment in respect of a **BM Unit** for a **Settlement Period** determined in accordance with paragraph 3 below;
- PCA = the available capability payment in respect of a **BM Unit** for a **Settlement Period** determined in accordance with paragraph 4 below; and
- PCS = the synchronised capability payment in respect of a **BM Unit** for a **Settlement Period** determined in accordance with paragraph 5 below.

Provided always that PTM shall be 0 in all **Settlement Periods** from and including that in which:-

- (a) the relevant **BM Unit** (or, in relation to a **CCGT Module**, any relevant **CCGT Unit**) fails a **Reactive Test** or a **Contract Test** until (and including) the **Settlement Period** in which a subsequent **Reactive Test** or **Contract Test** (as the case may be) is passed in relation to that **BM Unit** (or **CCGT Unit** (as the case may be)); or
- (b) the **User** fails (other than pursuant to an instruction given by **The Company** or as permitted by the **Grid Code**) to set the automatic voltage regulator of the **BM Unit** (or, in relation to a **CCGT Module**, any relevant **CCGT Unit**) to a voltage following mode until (and including) the **Settlement Period** in which the **User** notifies **The Company** that the automatic voltage regulator is so set; or

- (c) the **BM Unit** fails to comply with a **Reactive Despatch Instruction** due to the fact that the **BM Unit** (or, in relation to a **CCGT Module**, any relevant **CCGT Unit**) is unable to increase and/or decrease its Mvar **Output** (other than as a direct result of variations in **System** voltage) until (and including) the **Settlement Period** in which the **User** notifies **The Company** that the **BM Unit** is so able to comply; or
- (d) the **BM Unit** fails to have a Mvar range which includes the ability to provide zero Mvar at the **Commercial Boundary** until (and including) the **Settlement Period** in which the **User** notifies **The Company** that the **BM Unit** has or once more has such range; or
- (e) the **BM Unit** is affected by either a **Pre-Connection Reactive Despatch Network Restriction** or a **Temporary Enduring Reactive Despatch Network Restriction**, in each case until (and including) the **Settlement Period** in which notification is given to **The Company** pursuant to the **Grid Code** that such **Reactive Despatch Network Restriction** is no longer affecting that **BM Unit**.

**PART C: LEGAL TEXT TO MODIFY THE CUSC – WGAA2**

The text required to give effect to WGAA2 will be all the text outlined in Part A of Working Group Report, apart from the text specifically associated with part 3 of the original CAP169.

To be clear, this will include changes to:

- Part 1: Section 1, Section 4, Section 11, Schedule 2 and Schedule 3
- Part 2: Schedule 3 (2.8ii and Appendix 6, 1.2)

But will not include changes to:

- Part 3: Section 11 (definitions for Network Operator, Reactive Despatch Network Restriction and Pre-Connection Reactive Despatch Network Restriction) and Schedule 3 (Appendix 1, 2e and Appendix 2, 2e)

For the purposes of this Consultation Document the text associated with parts 1 and 2 has not been repeated here.

**PART D: LEGAL TEXT TO MODIFY THE CUSC – WGAA3**

WGAA3 will require the same changes as the original for parts 1 and 2 (as outlined in Part A of the Working Group Report Volume 2):

- Part 1: Section 1, Section 4, Section 11, Schedule 2 and Schedule 3
- Part 2: Schedule 3 (2.8ii and Appendix 6, 1.2)

For part 3 Section 11 only Reactive Despatch Network Restriction will require definition. Schedule 3 will require different drafting to that of the original.

For the purposes of the Consultation Document Volume 2 only the drafting associated with part 3 is included:

**1. Section 11**

**2. Schedule 3**

Please note, only the specific clauses requiring amendment have been included in this section.

Changes are marked as outlined in the table below:

<b>Legend:</b>
<u>Insertion</u>
<del>Deletion</del>



**WGAA3 Drafting**

Section 11

**“Reactive Despatch Network Restriction”** as defined in the Grid Code:

**Schedule 3, APPENDIX 1**

**Obligatory Reactive Power Service**  
**– Default Payment Arrangements**

The provisions of this Appendix 1, as referred to in sub-Paragraph 2.2 of this Part I, shall apply to the calculation of default payments for provision of the **Obligatory Reactive Power Service** from **BM Units**. All payments shall be expressed in pounds sterling.

1. **Total Payment**

$$\text{Total Payment (PT)} = \text{PU} [\text{£ per Settlement Period per BM Unit}]$$

where, subject always to paragraphs 5 and 6 below:

PU = the utilisation payment in respect of a **BM Unit** for a **Settlement Period** determined in accordance with paragraph 2 below.

2. **Utilisation Payment**

$$\text{PU} = \text{BP}_U * U [\text{£ per Settlement Period per BM Unit}]$$

Where

$$\text{BP}_U = \frac{46,270,000 * I * X * Y}{42,054,693} \quad [\text{£/Mvarh}]$$

Where

I = defined in paragraph 3 below;

X = 1 (unless the circumstances in sub-paragraphs (a) through to (d) apply)

And where X shall be 0.2 in all **Settlement Periods** from (and including) that in which:-

- (a) the relevant **BM Unit** (or, in relation to a **CCGT Module**, any relevant **CCGT Unit**) fails a **Reactive Test** until (and including) the **Settlement Period** in which a subsequent **Reactive Test** is passed in relation to that **BM Unit** (or **CCGT Unit** (as the case may be)); or
- (b) the **User** fails (other than pursuant to an instruction given by **The Company** or as permitted by the **Grid Code**) to set the automatic voltage regulator of the **BM Unit** (or, in relation to a **CCGT Module**, any relevant **CCGT Unit**) to a voltage following mode until (and including) the **Settlement Period** in which

the **User** notifies **The Company** that the automatic voltage regulator is so set; or

- (c) the **BM Unit** fails to comply with a **Reactive Despatch Instruction** due to the fact that the **BM Unit** (or, in relation to a **CCGT Module**, any relevant **CCGT Unit**) is unable to increase and/or decrease its Mvar output (other than as a direct result of variations in **System** voltage) until (and including) the **Settlement Period** in which the **User** notifies **The Company** that the **BM Unit** is so able to comply; or
- (d) the **BM Unit** fails to have a Mvar range which includes the ability to provide zero Mvar at the **Commercial Boundary** until (and including) the **Settlement Period** in which the **User** notifies **The Company** that the **BM Unit** has or once more has such range; and

Y = 1, except that Y shall be 0 in all **Settlement Periods** from and including that in which the **BM Unit** is affected by a **Reactive Despatch Network Restriction** until (and including) the **Settlement Period** in which notification is given to **The Company** pursuant to the **Grid Code** that such **Reactive Despatch Network Restriction** is no longer affecting that **BM Unit**

U = defined in Section 1 of Appendix 3

**Schedule 3, Appendix 2**

**Obligatory Reactive Power Service and Enhanced Reactive Power Services – Market Payment Mechanism**

The provisions of this Appendix 2, as referred to in sub-Paragraph 3.3(d)(i) of this Part I, shall apply to the calculation of payments in respect of **Tenders** comprising prices for and **Tendered Capability Breakpoints** relating to the **Obligatory Reactive Power Service** and in respect of **Tenders** comprising terms for the provision of the **Enhanced Reactive Power Services** specified in sub-Paragraph 1.2(a) of this Part I, in each case in respect of **BM Units**. All payments shall be expressed in pounds sterling. All algebraic terms contained in this Appendix 2 shall bear the meanings set out in paragraph 1 below unless the context otherwise requires.

1. **Definitions**

For the purposes of this Appendix 2, unless the context otherwise requires, the following terms shall have the following meanings:-

- |                 |   |  |
|-----------------|---|--|
| CA1,CA2 and CA3 | = | the available capability prices (expressed to apply to both leading and lagging) (£/Mvar/h) (as more particularly described in paragraph 2 of Appendix 5) as specified in the relevant <b>Market Agreement</b> ;   |
| CS1,CS2 and CS3 | = | the synchronised capability prices (expressed to apply to both leading and lagging) (£/Mvar/h) (as more particularly described in paragraph 2 of Appendix 5) as specified in the relevant <b>Market Agreement</b> ;  |
| CU1,CU2 and CU3 | = | the utilisation prices (expressed to apply to both leading and lagging) (£/Mvarh) (as more particularly described in paragraph 2 of Appendix 5) as specified in the relevant <b>Market Agreement</b> ;   |
| K               | = | in respect of <b>CCGT Modules</b> , the relevant configuration factor as specified in the relevant <b>Market Agreement</b> , otherwise 1;  |
| $Q_{lead}$      | = | defined in Section 2 of Appendix 3;  |
| $Q_{lag}$       | = | defined in Section 2 of Appendix 3;  |
| $QM_{ij}$       | = | <b>BM Unit Metered Volume</b> (as defined in the <b>Balancing and Settlement Code</b> );   |
| Q1, Q2 and Q3   | = | the contracted capability breakpoints (expressed to apply to both leading and lagging) in whole Mvar as may be specified in the relevant <b>Market Agreement</b> , where: <ul style="list-style-type: none"> <li>(i) <math>Q1 = TQ1,</math><br/><math>Q2 = TQ2</math><br/>and <math>Q3 = QC</math><br/>where <math>TQ2 &lt; QC \leq TQ3</math></li> <li>(ii) <math>Q1 = TQ1,</math><br/><math>Q2 = QC</math><br/><math>Q3 = null</math></li> </ul> |

where  $TQ1 < QC \leq TQ2$

- (iii)  $Q1 = QC,$   
 $Q2 = \text{null}$   
 $Q3 = \text{null}$   
 where  $0 \leq QC \leq TQ1$

SPD	=	the duration of a <b>Settlement Period</b> , being 0.5;
TQ1, TQ2 and TQ3	=	defined in Appendix 5;
$U_{\text{lead}}$	=	defined in Section 1 of Appendix 3;
$U_{\text{lag}}$	=	defined in Section 1 of Appendix 3;
V	=	the system voltage range performance factor (expressed to apply to both leading and lagging) as calculated in accordance with the formulae set out in the relevant <b>Market Agreement</b> , otherwise 1;
$MEL_i(t)$	=	<b>Maximum Export Limit</b> (as defined in the <b>Balancing and Settlement Code</b> ).

2. **Total Payment**

Total Payment (PTM) = PUM + PCA + PCS *[£ per Settlement Period per BM Unit]*

where, subject always to paragraphs 6, 7 and 8 below:

- PUM = the utilisation payment in respect of a **BM Unit** for a **Settlement Period** determined in accordance with paragraph 3 below;
- PCA = the available capability payment in respect of a **BM Unit** for a **Settlement Period** determined in accordance with paragraph 4 below; and
- PCS = the synchronised capability payment in respect of a **BM Unit** for a **Settlement Period** determined in accordance with paragraph 5 below.

Provided always that PTM shall be 0 in all **Settlement Periods** from and including that in which:-

- (a) the relevant **BM Unit** (or, in relation to a **CCGT Module**, any relevant **CCGT Unit**) fails a **Reactive Test** or a **Contract Test** until (and including) the **Settlement Period** in which a subsequent **Reactive Test** or **Contract Test** (as the case may be) is passed in relation to that **BM Unit** (or **CCGT Unit** (as the case may be)); or
- (b) the **User** fails (other than pursuant to an instruction given by **The Company** or as permitted by the **Grid Code**) to set the automatic voltage regulator of the **BM Unit** (or, in relation to a **CCGT Module**, any relevant **CCGT Unit**) to a voltage following mode until (and including) the **Settlement Period** in which the **User** notifies **The Company** that the automatic voltage regulator is so set; or

- (c) the **BM Unit** fails to comply with a **Reactive Despatch Instruction** due to the fact that the **BM Unit** (or, in relation to a **CCGT Module**, any relevant **CCGT Unit**) is unable to increase and/or decrease its Mvar **Output** (other than as a direct result of variations in **System** voltage) until (and including) the **Settlement Period** in which the **User** notifies **The Company** that the **BM Unit** is so able to comply; or
- (d) the **BM Unit** fails to have a Mvar range which includes the ability to provide zero Mvar at the **Commercial Boundary** until (and including) the **Settlement Period** in which the **User** notifies **The Company** that the **BM Unit** has or once more has such range; or
- (e) the **BM Unit** is affected by a **Reactive Despatch Network Restriction** until (and including) the **Settlement Period** in which notification is given to **The Company** pursuant to the **Grid Code** that such **Reactive Despatch Network Restriction** is no longer affecting that **BM Unit**

---

PART E – CHANGES TO THE METHODOLOGY FOR THE AGGREGATION OF REACTIVE POWER METERING

**PART E - CHANGES TO THE METHODOLOGY FOR THE AGGREGATION OF REACTIVE POWER METERING**

**INSERTIONS ARE UNDERLINED AND MARKED IN BLUE**  
**DELETIONS ARE STRUCK THROUGH AND MARKED IN RED**

# **OBLIGATORY AND ENHANCED REACTIVE POWER SERVICES**

## **Methodology Document for the Aggregation of Reactive Power Metering**

September 2009 ~~April 2007~~

Network Operations  
National Grid  
National Grid House

**Warwick Technology Park**

Gallows Hill  
Warwick  
CV34 6DA

**nationalgrid**

<b>CONTENTS</b>		<b>PAGE</b>
1.	Definitions and Interpretations	3
2.	Introduction	3
3.	Category A Methodology	4
4.	Category B Methodology	6
5.	Category C Methodology	9
6.	Category D Methodology	12

## 1. DEFINITIONS AND INTERPRETATIONS

National Grid Electricity Transmission plc (“The Company”) is a member of the National Grid plc group of companies. National Grid is the trading name for National Grid plc.

In this document, except where the context otherwise requires, terms and expressions found in Schedule 3 to the Connection and Use of System Code (CUSC) have the same meanings, interpretations and constructions.

For the avoidance of doubt in this document, when considering the circuits that connect any source of Reactive Power to the GB Transmission System, the terms “leading reactive energy” and “lagging reactive energy” refer to “Mvarh import value” and “Mvarh export value” respectively, as defined in Appendix B of the Metering Codes of Practice 1 & 2<sup>1</sup> entitled “Labelling of Meters for Import and Export”. The Metering Codes of Practice can be found on the Elexon website at:

<http://www.elexon.co.uk/bscrelateddocs/codesofpractice/default.aspx>

## 2. INTRODUCTION

This document contains the metering aggregation methodologies for use in calculating the payments for the provision of either an Obligatory or Enhanced Reactive Power Service from any reactive power equipment including, for the avoidance of doubt, BM Units, Non-BM Units, Generating Units, [Power Park Modules](#) and other Plant and Apparatus or equipment.

The various meter aggregation methodologies set out in this document (as amended or supplemented from time to time) are designed to simulate, as far as reasonably practicable, the presence of a single meter at the Commercial Boundary in order to ascertain, in respect of reactive power equipment, the Mvarh import and Mvarh export values to be used in the calculation of payments to be made by The Company for reactive power produced by the reactive power equipment.

**Where the reactive power equipment has a single meter located at or close to the Commercial Boundary, there is no requirement to apply any of the aggregation methodologies contained in this document and payments will be based on the actual recorded reading of the meter. In these cases, the provisions relating to meter aggregation in the relevant Ancillary Services Agreement will be designated “Not Applicable”.**

---

<sup>1</sup>Entitled on the web site as “The metering of circuits with a rated capacity exceeding 100 MVa for settlement purposes” (Metering Codes of Practice 1) & “The metering of circuits with a rated capacity exceeding 100 MVa for settlement purposes” (Metering Codes of Practice 2)



Reactive power equipment can comprise inter alia:-

- a) a single Generating Unit, Plant or Apparatus, with its own connection via a transformer to the Commercial Boundary with the GB Transmission System or the Distribution System of the host Public Distribution System Operator (PDSO)
- b) a BM Unit comprising several separate Generating Units or Power Park Units. For example a combined cycle gas turbine module (CCGT Module) either directly connected or within an embedded power station, or a Power Park Module
- c) a BM Unit comprising a single Generating Unit which shares a transformer or other connection to the Commercial Boundary with another Generating Unit
- d) one of the above but with more than one possible route of connection to the Commercial Boundary

As at September 2009 ~~April 2007~~, four distinct Metering System configurations in respect of reactive power equipment have been identified as necessary as specified in sub-paragraph 2.4 of Appendix 4 of Schedule 3 to the CUSC. This document sets out below the four methodologies (referred to in this document as "Categories A, B, C and D") which can be applied to these specific Metering System configurations.

### 3. CATEGORY A

This category covers the following cases:-

- (i) The reactive power equipment is metered by **one** set of Metering Equipment providing the Mvarh import and export values, which is located at the low voltage side of a generator step-up transformer.
- (ii) The reactive power equipment is metered by **one** set of Metering Equipment providing the Mvarh import and export values, which is located at the high voltage side of the generator step-up transformer, but physically remote from the Commercial Boundary.

The following two figures illustrate the two cases described above to which the Category A methodology described below can be applied. For illustrative purposes only, the reactive power equipment is a BM Unit represented as a single Generating Unit in figure (i) and several Generating Units/Power Park Units within a CCGT Module/Power Park Module in figure (ii), each with meters located at points marked "M".

Figure (i) Metering Equipment positioned at the low voltage side of the generator step-up transformer.

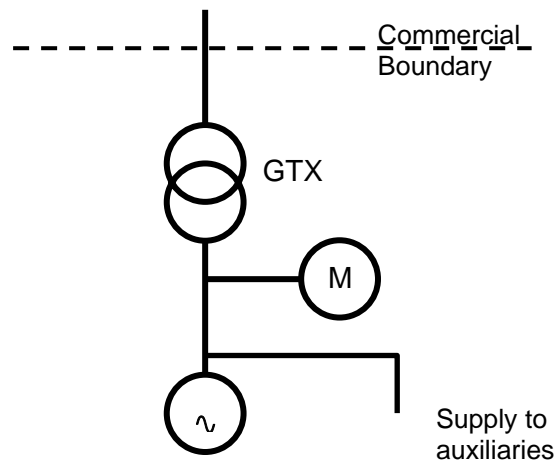
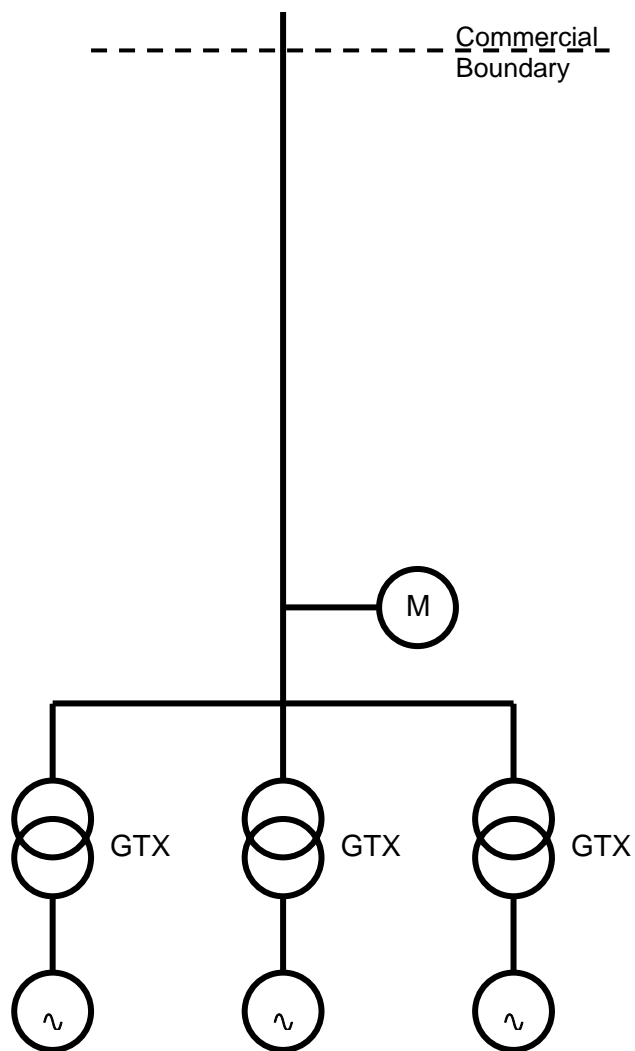

Figure (ii) Metering Equipment positioned at the high voltage side of the generator step-up transformer, but at a distance from the Commercial Boundary.



## Methodology

No meter aggregation is required. However, in order to provide Mvarh import and Mvarh export values for the reactive power equipment at the Commercial Boundary, appropriate loss adjustment factors must be agreed between the User and The Company. In some cases, and subject to agreement, it may be possible to perform the adjustment within the Metering Equipment itself. If not, the governing principles for any Meter loss adjustment will be the same as those used in the LV to HV conversion formulae used for the calculation of Reactive Power capability at the Commercial Boundary as specified in the relevant Ancillary Services Agreement.

### 4. CATEGORY B

This category covers the case where the reactive power equipment has two or more Meters measuring Mvarh import and export values. This includes the following cases:

- The reactive power equipment is a BM Unit comprising a single CCGT Module or an embedded power station made up of several Generating Units/[Power Park Units](#), each with its own Meter located at the High Voltage side of the transformer.
- Where any one or more of the Meters is not positioned at or close to the Commercial Boundary then a method of Meter loss adjustment must first be agreed in accordance with the Category A methodology above. The adjusted Meter readings derived applying the Category A methodology will then be used in the aggregation methodology described below.

Figure (iii)

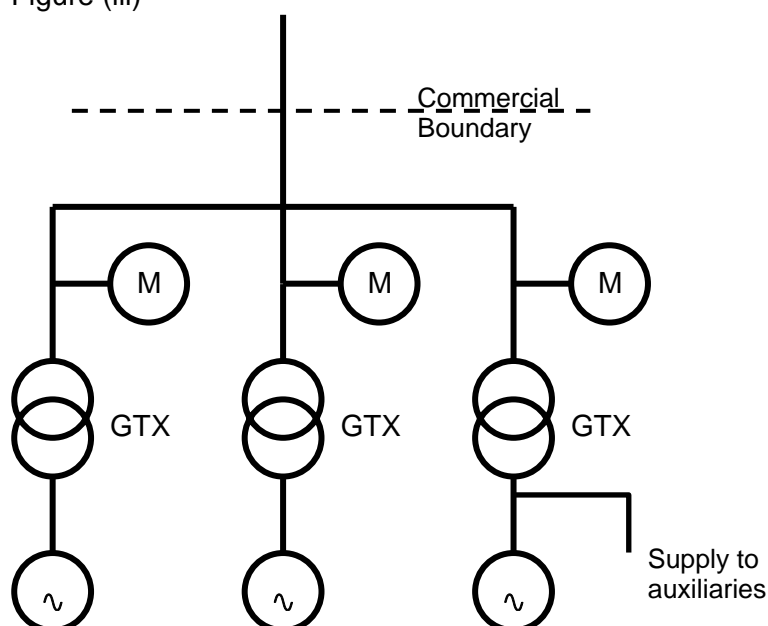

## Methodology

In order to reflect possible Reactive Power imbalances across the metered points, two aggregation methodologies will apply, namely *linear addition* and *separation of totals*.

#### LINEAR ADDITION

Linear addition is the straight forward addition of the readings of the Mvarh leading and Mvarh lagging Meters at each metered point to give total Mvarh leading and Mvarh lagging reactive energy readings respectively. Linear addition is only applicable when all the meter values for a Settlement Period are in the same sense (i.e. providing all leading or all lagging reactive energy), or when both the leading and lagging meter values for the Settlement Period are reasonably balanced across all the metered points. Hence its application is limited to the following specific circumstances when, during a Settlement Period all Generating Units or embedded loads within the BM Unit are supplying in:-

- (a) always lagging (or zero) reactive energy; or
- (b) always leading (or zero) reactive energy; or
- (c) successive leading and lagging reactive energy or vice-versa, where both the leading and lagging values are each reasonably balanced.

#### SEPARATION OF TOTALS

In all other circumstances, separation of totals should be used to avoid the inclusion of Reactive Power which is circulating between individual Generating Units. By applying this aggregation methodology, the total of the metered leading reactive energy is subtracted from the total of the metered lagging reactive energy.

If the result is positive then the total is considered to be lagging reactive energy, and the lagging reactive energy for the BM Unit, (i.e. the CCGT Module [or Power Park Module](#) or embedded power station), is equal to the numeric value of the result and leading reactive energy is deemed to be zero.

If the result is negative then the total is considered to be leading reactive energy, and the leading reactive energy for the BM Unit, (i.e. the CCGT Module [or Power Park Module](#) or embedded power station), is equal to the numeric value of the result and lagging reactive energy is deemed to be zero.

The mathematical definitions of both the linear addition methodology and the separation of totals methodology are stated below, with the variables used in the mathematical definitions having the following definitions:-

n The total number of units

lead<sub>total</sub> The calculated leading reactive energy in a Settlement Period for a BM Unit, in Mvarh (a positive number or zero)

lag <sub>total</sub>	The calculated lagging reactive energy in a Settlement Period for a BM Unit, in Mvarh (a positive number or zero)
lead <sub>i</sub>	The metered leading reactive energy in a Settlement Period for the <i>i</i> th unit within a BM Unit, in Mvarh (a positive number or zero)
lag <sub>i</sub>	The metered lagging reactive energy in a Settlement Period for the <i>i</i> th unit within a BM Unit, in Mvarh (a positive number or zero)
total	A variable defined in the equations below which can be positive, negative or zero.

### Linear Addition

$$lead_{total} = \sum_{i=1}^n lead_i$$

$$lag_{total} = \sum_{i=1}^n lag_i$$

### Separation of Totals

$$total = \sum_{i=1}^n lag_i - \sum_{i=1}^n lead_i$$

If total > 0

then

$$\begin{aligned} lag_{total} &= total \\ lead_{total} &= 0 \end{aligned}$$

otherwise

$$\begin{aligned} lag_{total} &= 0 \\ lead_{total} &= |total| \end{aligned}$$

### Application Criteria for Linear Addition

Linear Addition will be applied where either:

- (i) [max(lag<sub>i</sub>) = 0 or max(lead<sub>i</sub>) = 0]

(All Generating Units providing lagging (or zero) reactive energy or all Generating Units providing leading (or zero) reactive energy)

or:

(ii)  $[\min(\text{lag}_i) > 0 \text{ and } \min(\text{lead}_i) > 0]$

(All Generating Units providing both leading and lagging reactive energy where the group of leading and lagging metered values are such that the maximum group value is no greater than 1.1 times the minimum group value)

ie: maximum lagging metered value  $\leq 1.1 \times$  minimum lagging metered value

maximum leading metered value  $\leq 1.1 \times$  minimum leading metered value.

Otherwise separation of totals is the applicable methodology, rather than Linear Addition.

## 5. CATEGORY C

The following meter aggregation methodologies cover those cases where the reactive power equipment is an auxiliary gas turbine generating unit (GT), connected to the unit auxiliary board of a main Generating Unit.

In such cases the export from the GT is either via the unit (UTX) / generator (GTX) step-up transformer when the main Generating Unit is synchronised or via power station interconnectors and the station (STX) step-up transformer when the main Generating Unit is not synchronised. Figure (iv) shows one such arrangement and indicates the typical position of the Reactive Power Meters.

By applying tests to determine whether both or only one of the main Generating Unit and the GT are synchronised, the appropriate Meter loss adjustment and Meter aggregation methodologies for the operating conditions are determined.

**When the GT is synchronised it may be producing both active and reactive power or operating as a synchronous compensator producing only reactive power.**

Figure (iv)

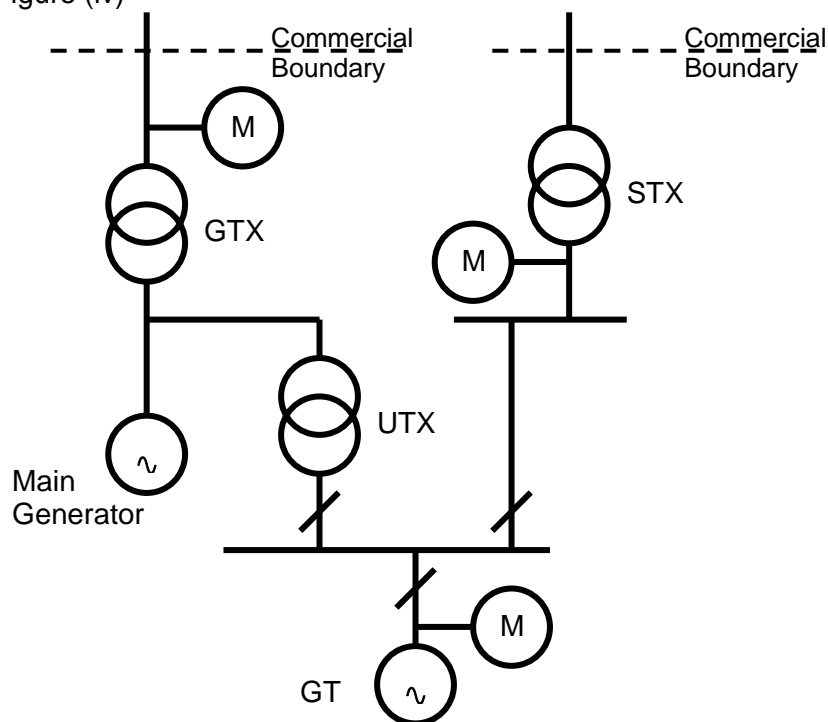

In order to provide Mvarh import and Mvarh export values for the GT at the HV side of the generator and station step-up transformers when both the main Generating Unit and/or the GT are synchronised, appropriate Meter loss adjustment factors are required to be applied to the GT Meter readings. These will be dependent upon actual site/plant arrangement and agreed reference operating conditions. These will be subject to agreement on a site by site basis between The Company and the User.

### Methodology

The main Generating Unit is identified as synchronised by the condition  $A_{ij} > 5\text{MWh}$  in a Settlement Period.

The GT is identified as synchronised by the metered Mvarh import or export value, measured at the GT Meter, being greater than 2.5 Mvarh in a Settlement Period.

Let:

- |                          |   |   |
|--------------------------|---|---|
| Grlag and Grlead         | = | the Mvarh export and import values at the HV side of the generator step-up transformer.   |
| Gtlagcomp and Gtleadcomp | = | the Mvarh export and import values of the GT as adjusted to the values at the Commercial Boundary by the application of a Meter loss adjustment factor based on a “predominant reactive energy flow path”, agreed between The Company and the |

User for that Meter. (ie One Meter loss adjustment factor will apply for export values and one Meter loss adjustment factor will apply to import values whether the reactive flow is via the generator or station step-up transformer.)

Three case scenarios are dealt with below

1. Where only the main Generating Unit is synchronised:-

Payments will be made for the main Generating Unit only and will be calculated utilising the Grlag and/or Grlead Mvarh export and import values at the main Generating Unit payment rate.

2. Where only the GT is synchronised:-

Payments will be made for the GT only and will be calculated utilising the appropriate GT Mvarh export and import values, adjusted in accordance with the appropriate meter loss adjustment factor at the GT payment rate.



3. Where both the main Generating Unit and the GT are synchronised:-

(a) Where  $G_{rlag} \geq G_{tlagcomp}$

Payments will be calculated as follows:-

- i) For the main Generating Unit,  $(G_{rlag} - G_{tlagcomp})$  Mvarh export values at the main Generating Unit payment rate, and
- ii) For the GT,  $G_{tlagcomp}$  Mvarh export value at the GT payment rate.

(b) Where  $G_{rlag} < G_{tlagcomp}$

- i) For the main Generating Unit,  $(G_{rlag} - G_{tlagcomp})$  Mvarh export values will be zero and so no payment will be due at the main Generating Unit payment rate, and
- ii) For the GT,  $G_{tlagcomp}$  Mvarh export value at the GT payment rate.

(c) Where  $G_{rlead} \geq G_{tleadcomp}$

Payments will be calculated as follows:-

- i) For the main Generating Unit,  $(G_{rlead} - G_{tleadcomp})$  Mvarh import values at the main Generating Unit payment rate, and
- ii) For the GT,  $G_{tleadcomp}$  Mvarh import value at the GT payment rate.

(d) Where  $G_{rlead} < G_{tleadcomp}$

- i) For the main Generating Unit,  $(G_{rlead} - G_{tleadcomp})$  Mvarh export values will be zero and so no payment will be due at the main Generating Unit payment rate, and
- ii) For the GT,  $G_{tleadcomp}$  Mvarh export value at the GT payment rate.

The above four cases apply to instances where there is all leading or all lagging reactive energy during a Settlement Period **and** where both leading and lagging operation occurs in a Settlement Period.

## 6. CATEGORY D

This category covers the case where the Generating Unit connected at the Commercial Boundary also supplies an embedded load.

In such cases the reactive power produced by the Generating Unit needs to be determined in relation to the reactive nature of the load and whether the Generating Unit has been despatched to provide lagging or leading reactive power. Figure (v) shows one such arrangement and indicates the typical positions of the Reactive Power Meters.

Figure (v)

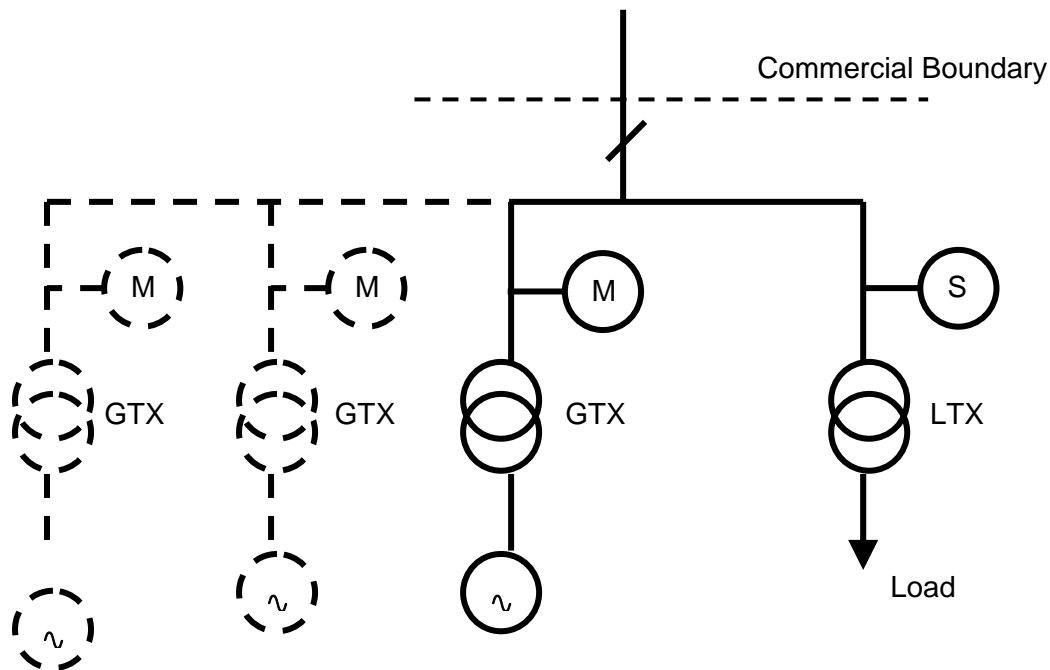

## Methodology

The Metering Codes of Practice One and Two define the following convention to be used for determining the flow of energy:

Flow of Active Energy	Power Factor	Flow of Reactive Energy
Import	LAGGING	Import
Import	LEADING	Export
Import	UNITY	Zero
Export	LAGGING	Export
Export	LEADING	Import
Export	UNITY	Zero

This means that for a Load, the Leading Mvars will be exporting (towards the Commercial Boundary), whereas leading Mvars for a Generating Unit will be importing (away from the Commercial Boundary).

In order to reflect the impact of the embedded load on the reactive power from the Generating Unit at the Commercial Boundary then three aggregation methodologies will need to apply.

Let

$G_{rlag}$  and  $G_{rlead}$  = the Mvarh export and import values at the HV side of the Generating Unit step-up transformer (M in figure v).

$L_{dlag}$  and  $L_{dlead}$  = the Mvarh import and export values at the HV side of the Embedded Load transformer (S in figure v).

Three case scenarios are dealt with below

1. Where both Unit and Load are exporting (Grlag and Ldlead) or when both Unit and Load are importing (Grlead and Ldlag):-

Payments will be made for the Generating Unit only and will be calculated utilising the Grlag and/or Grlead Mvarh export and import values at the main Generating Unit payment rate.

2. Where Unit is exporting and Load importing (Grlag and Ldlag):-

Payments will be made for the Generating Unit less the effect of the Embedded Load and will be calculated using  $(Grlag - Ldlag)$  values at the main Generating Unit payment rate. Where  $(Grlag - Ldlag) < 0$  then the value at the main Generating Unit will be zero.

3. Where Unit is importing and Load exporting (Grlead and Ldlead):-

Payments will be made for the Generating Unit less the effect of the Embedded Load and will be calculated using  $(Grlead - Ldlead)$  values at the main Generating Unit payment rate. Where  $(Grlead - Ldlead) < 0$  then the value at the main Generating Unit will be zero.

The above three cases apply to instances where there is all leading or all lagging reactive energy during a Settlement Period **and** where both leading and lagging operation occurs in a Settlement Period.

Where there is more than one Generating Unit (as indicated by the plant drawn by dotted lines in Figure v), then the total Generating Mvars (Grlead and Grlag) will be determined in accordance with Methodology B in this document.

**PART F – REPRESENTATIONS TO THE WORKING GROUP CONSULTATION**

Three representations were received to the Working Group consultation; these are detailed and attached below:

<b>Reference</b>	<b>Company</b>
CAP169-WGC-01	British Wind Energy Association
CAP169-WGC-02	Edf Energy
CAP169-WGC-03	RWE NPower

**Virk, Bali**

---

**From:** Helen Snodin [helen.snodin@xeroenergy.co.uk]  
**Sent:** 01 June 2009 16:25  
**To:** .Box.Cusc.Team  
**Cc:** 'BWEA Gordon Edge'; richard.ford@res-ltd.com; nigel.scott@xeroenergy.co.uk  
**Subject:** CAP 169 Working Group report BWEA response

Dear CUSC Team,

This is a short response to the CAP 169 Working Group (WG) report on behalf of our client the British Wind Energy Association (BWEA).

We note the discussions on Part 3 on “recognition of distribution network imposed restriction on reactive power.” As a rule, we feel it would be more appropriate to provide the capability as and when it is deemed to be required for areas of the network, as opposed to mandatory requirements for projects of a certain size. We note that the WG considered Alternatives to Part 3, including, in para 4.27 the “removal of reactive capability requirement, or separation of steady state and dynamic capability requirements....”

On the commentary given in 4.27 we would note that dynamic and steady state requirements are not necessarily the same and it is not clear how the WG arrived at the conclusion that the steady state inherently includes dynamic. Taking wind as an example, many wind turbines can provide a steady state range but the dynamic capability is limited, e.g. it may not be as fast as NGET would like. This exact reason has led to the inclusion of STATCOMs and similar at many wind farms, even where the turbines could provide the steady state capability. It would therefore seem to be the case that separation of dynamic and steady state could relieve many wind farms of a significant cost (i.e. for STATCOMs or similar). For short term DNO restrictions then full capability could be required – for long term restrictions there could be a reduction in required capability.

I hope you find these comments useful. If you would like to discuss this response please do not hesitate to contact my colleague Nigel Scott (cc'd) or Gordon Edge at the BWEA.

Kind Regards

Helen Snodin



Xero Energy Ltd  
Registered in Scotland:  
SC313697 at 2/1A, 2 Parkgrove  
Terrace  
Glasgow G3 7SD, UK

Helen Snodin

Tel: +44 (0)141 357 1575  
Mob: +44 (0)788 799 1520  
[helen.snodin@xeroenergy.co.uk](mailto:helen.snodin@xeroenergy.co.uk)  
[www.xeroenergy.co.uk](http://www.xeroenergy.co.uk)

---

To: [cusc.team@uk.ngrid.com](mailto:cusc.team@uk.ngrid.com)

EDFE Response to CAP169 Working Group Consultation



Executive Summary

- CAP169 proposes a solution to a defect in the CUSC in relation to a lack of alignment with the requirements of the Grid Code.
- The proposed solution will introduce a new defect into the CUSC in relation to Embedded Power Stations operating under Distribution imposed restrictions on Reactive capability.
- Neither of the proposed solutions to address this new defect, in Part 3, are appropriate.
- EDFE would propose that under such circumstances a zero payment be made.
- Neither CAP169 nor any of its alternatives better facilitates the applicable objectives as a result of the defect that will be introduced.

Thank you for this opportunity to respond to the Working Group Consultation for CAP 169 - Provision of Reactive Power from Power Park Modules, Large Power Stations and Embedded Power Stations.

We fully recognise the rationale in relation to the raising of this proposal, such that the CUSC is not currently aligned with the Grid Code requirements placed upon Power Park Modules, Large Power Stations and Embedded Power Stations. This lack of alignment results in these units installing equipment for the provision of Reactive power as per the Grid Code requirements, which cannot then be utilised by National Grid under the current arrangements. As such the units are unable to recover the cost of this mandatory investment. To the extent that this is the case, we agree that there is a defect in the CUSC that needs to be addressed.

To this end we support the principles of Part 1 and Part 2 of this proposal. However, we note that in availing these units of the ability to conclude Mandatory Service Agreements (MSA) and therefore at least receive the Obligatory Reactive Power Service payment (ORPS) that this in turn would create a new defect, such that embedded units under a Distribution imposed Reactive Power restriction may not be able to act in accordance with instructions from National Grid.

We note that Part 3 attempts to resolve this new defect by limiting the ORPS payment to 20% where a restriction is identified, and that WGAA1 attempts to clarify the application of this payment reduction to apply only where a restriction is notified as a condition of connection or where a temporary restriction endures for 12 months. We further note that WGAA2 proposes Parts 1 & 2 only as a means of addressing the original defect but avoiding the complexity of resolving this new issue.

For the avoidance of doubt we do not consider that WGAA2 should be progressed. The new defect that Parts 1 & 2 would create must be resolved at the same time that these proposals are implemented, should the Authority choose to approve CAP169.

EDFE do not consider that the current proposals for resolving the defect CAP169 would introduce are appropriate. As a point of principle we do not consider that amending the payment structure in the CUSC in relation to what amounts to a 3<sup>rd</sup> Party restriction is the correct approach. In addition, we note that in the case of embedded generators, the inability to vary reactive power provision in accordance

with instruction from National Grid would have some potential implications. We consider that it may be necessary for National Grid to procure additional reactive power provision from an alternative unit as a result of the embedded unit's failure to comply with the instruction. This would incur additional cost that would be included in total BSUoS. As a result the remainder of all Users would pay for the inability of the embedded unit to respond. Should the embedded unit also receive BSUoS revenue as a result of being regarded as negative demand, then the increased BSUoS would result in additional revenue to the embedded unit for failing to comply with a National Grid instruction. We do not consider this to be the correct signal to incentivise resolution of the restriction.

We would therefore propose an alternative solution for Part 3 whereby the existence of such a 3<sup>rd</sup> party restriction, thereby preventing the embedded unit providing the service in accordance with National Grid instruction should result in £0 (zero) payment. In addition, under such circumstances National Grid would not be permitted to issue instructions to the unit (for which the unit would then receive no payment).

We would also recommend that National Grid investigates the existing governance arrangements relating to the circumstances under which Distribution restrictions prevent units complying with the requirements of the Grid Code and CUSC. We consider that where such restrictions are properly imposed then the affected units should at the least be required to request derogations in respect of their obligation to comply. Such derogation could be time-banded where it would appear that the Distribution restriction could be reasonably and economically removed.

It is therefore our view that, despite acknowledging that there is currently a defect in the CUSC which Parts 1 & 2 would address, in the absence of an appropriate solution to the subsequent defect (which they would introduce if implemented), we do not consider that CAP169 in its current form better facilitates the applicable objectives.

We consider that the differential treatment and perverse incentives that Part 3 would introduce would not better facilitate objective (a) as under these circumstances National Grid would not be able to instruct a unit under DNO restriction appropriately.

With regard to objective (b) we concur with the view in section 6.2 of the document that "the possible ability for National Grid to choose to instruct a generator under restriction within the restricted range (receiving a 20% payment) as an alternative to a generator for which full payment would be required." has merit. This view taken together with the additional perverse incentives identified above do not meet the requirement of objective (b).

For the avoidance of doubt, as WGAA2 does not attempt to address the new defect that would be introduced by parts 1 & 2 it does not better facilitate the applicable objectives than either the baseline or the original.

If you would like to discuss any aspect of this response further, please contact James Evans on 01452 656707.

Regards

James Evans

## ANNEX 6 - CUSC Working Group consultation – RESPONSE Proforma

### CAP169 Provision of Reactive Power from Power Park Modules, Large Power Stations and Embedded Power Stations

CUSC parties are invited to respond to this consultation, expressing their views [and in respect of the specific questions detailed below]. Parties are invited to supply the rationale for their responses.

Please send your responses [cusc.team@uk.ngrid.com](mailto:cusc.team@uk.ngrid.com) by 1st June 2009. Please note that any responses received after the deadline may not receive due consideration by the Working Group.

Any queries on the content of the consultation should be addressed to [carole.hook@uk.ngrid.com](mailto:carole.hook@uk.ngrid.com)

These responses will be considered by the Working Group and will record the conclusion they reach on your request; as well as showing their discussions of your requests and the conclusion they reach on your request. If appropriate the group will amend their report accordingly and will record your response in the Working Group Report.

<b>Respondent:</b>	<i>Raoul Thulin, <a href="mailto:raoul.thulin@rwe.com">raoul.thulin@rwe.com</a>, 01793 892634</i>
<b>Company Name:</b>	RWE Npower
<b>Please express your views including rational with regard to the Working Group Consultation?</b>  <b>Including any issues, suggestions or queries</b>	No comments.
<b>Do you believe that the proposed original or any of the alternatives better facilitate the CUSC applicable objectives, please state your reasoning?</b>	We believe that Working Group Alternative 2 better facilitates the CUSC applicable objectives. Parts 1 and 2 of the original Amendment Proposal facilitate the efficient procurement of reactive power by expanding the number of available providers that can be



	<p>instructed and remunerated under the terms of a MSA. This will provide a route to market for the reactive capability that generators are obliged to have under the Grid Code. The third part of the original Amendment Proposal relating to generators restricted by DNOs does not better facilitate competition in the provision of reactive power as it only addresses the payments made by National Grid but does not deal with the obligations on the generator to maintain capability or with the potential benefits to the DNO that the reactive power provision may provide. In doing so, the provisions of the original Amendment Proposal would introduce potential pricing anomalies whereby a provider receiving reduced payments may provide an alternative source of reactive power to a provider that is not restricted in the same way and therefore entitled to a full payment for the service, thereby stifling competition.</p>
<p><b>Do you support the proposed implementation of CAP169, if no please state why and provide an alternative suggestion were possible?</b></p> <p><b>Do you agree with the Working Group suggested implementation date, if no please state why and provide an alternative suggestion if possible?</b></p>	<p>We support the implementation of Working Group Alternative 2 but we do not support the implementation of the original CAP169 for the reasons outlined above.</p> <p>A proper solution to the perceived deficiency identified in the Amendment Proposal would entail a mechanism whereby the beneficiary of the reactive power (the DNO) would be responsible for payments or, if no benefit is derived from the reactive power, then the obligation to install the reactive power capability should be removed. However, we recognise that such a solution is outside the scope of the CUSC.</p> <p>The suggested implementation date of three months after Authority decision seems reasonable.</p>
<p><b>Any other comments?</b></p>	<p><i>No</i></p>
<p><b>Do you wish to raise a WG Consultation Request for the Working Group to consider?</b></p>	<p><i>NO</i></p>

### Specific questions for CAP169:

Q	Question	Rationale
1.	Are the 12 and 24 month time period proposed in draft Working Group Alternative Amendment 1 appropriate?	Any time limit will ultimately be an arbitrary choice. However, the 12 and 24 month periods seem reasonable should this part of the Amendment proposal be approved.
2.	The implementation timescales proposed in section 7 of this document	The suggested implementation date of three months after Authority decision seems reasonable.
3.	Comments invited on the changes proposed to the Methodology for the Aggregation of Reactive power Metering.	We believe that the inclusion of Power Park Modules in the methodology statement has been reflected in the proposed changes to the document.
4.	Comments invited on the proposal for communication of a reactive despatch restriction to be made by both generators and DNOs.	We believe that this matter should be the subject of debate at the GCRP to identify whether any alternative routes for communication with National Grid are more appropriate.